

REBEL[®] COMMERCIAL PACKAGED ROOFTOP SYSTEMS

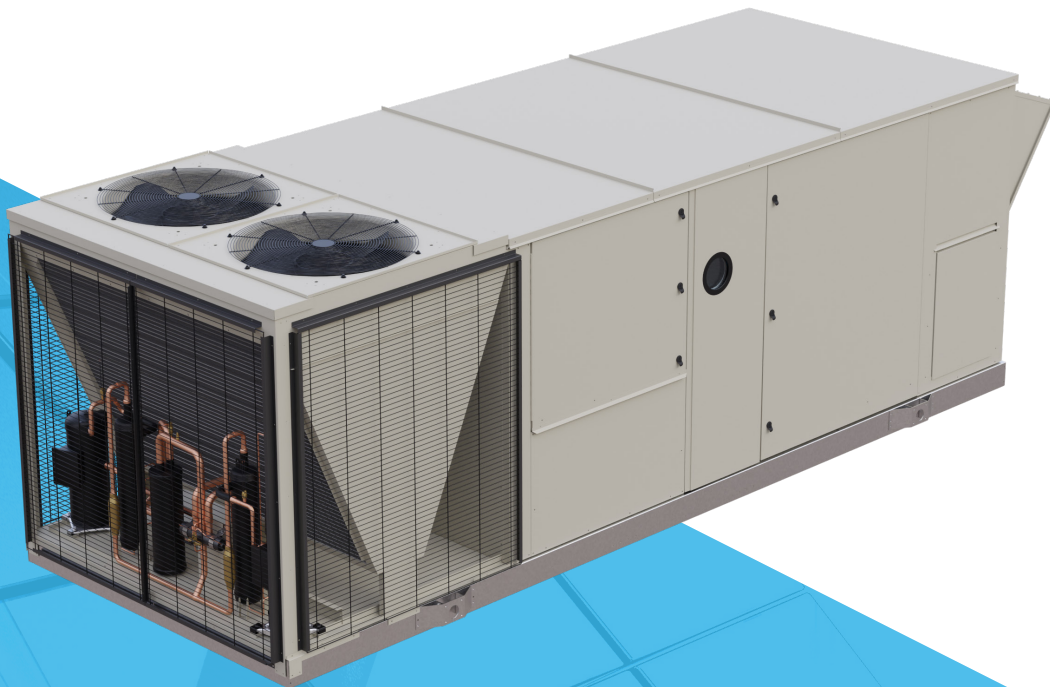

- HEATING AND COOLING
- MODELS: DPS 03 - 31
- R-32 REFRIGERANT
- MICROTECH UNIT CONTROLLER

Table of Contents

Introduction	3
Compliance Statements	5
Unit Labels	5
Mechanical Installation	6
Roof Curb Assembly and Installation	14
Lifting Guidance	25
Transit and Temporary Storage	27
Unit Piping - Condensate Drain Connection	27
Damper Assemblies	28
Cabinet Weather Protection	28
Installing Ductwork	29
Optional Ultraviolet (UV) Lights	31
Electrical Installation	33
Electrostatic Discharge (ESD)	33
Refrigeration System	37
DPS Component Description	39
Compressor Overload	42
A2L Mitigation Sequences	43
Modulating Hot Gas Reheat	44
Optional Electric Heat	46
Optional Gas Heat	48
Daikin Applied Tubular Heater Series	48
Manifold Diagrams	57
Gas Heating Pressure Management Diagrams	61
Gas Heating Pressure Data	64
Maxitrol EXA Star Controller	69
Sequences of Operation	70
Refrigeration Only Controls (ROC)	72
Fuel and Altitude Conversions	73
Start-Up Procedures	74
Operating Procedures	75
Maxitrol EXA Star Valve Over-Traveled State Calibration	98
Optional Hot Water Heat	100
Hot Water Heater Design	100
Energy Recovery Wheel	101
System Description	101
Outdoor Air Monitor	104
Thermal Dispersion Airflow Measurement Technology	104
ECM Fans	113

Unit Options	116
Typical Wiring Diagrams	118
Preparing for Start Up	134
Pre-Start of Unit	134
Spring Isolated Fans	134
Servicing Control Panel Components	135
Power-Up	135
Fan Start-Up	135
Check, Test, and Start the Unit	136
Economizer Start-Up	136
Compressor Start-Up	136
Set Up for Optimum Control	137
Air Balancing	137
Energy Recovery Wheel	137
Fixed Plate Exchanger	138
CORE® Enthalpy Fixed Plate Exchanger	138
Sensible Fixed Plate Heat Exchanger	139
Final Control Settings	141
Final Control Settings	141
Maintaining Control Parameter Records	141
R-32 Guidelines	142
Maintenance	151
Performing Service Maintenance	151
Servicing the A2L Refrigeration System	151
Planned Maintenance	152
Unit Storage	152
Periodic Service and Maintenance	153
Refrigerant Charge	153
Refrigerant Charging and/or Evacuation	154
Phase Voltage Monitor (PVM)	155
Cleaning Option E Coated Coils	156
Service and Warranty	157
Replacement Parts	157
Limited Warranty	158
Rooftop Equipment Warranty Registration Form	159
Warranty Exclusion	159
In-Warranty Return Material Procedure	159
Warranty Registration Form	160

©2026 Daikin Applied, Minneapolis, MN. All rights reserved throughout the world. This document contains the most current product information as of this printing. Daikin Applied Americas Inc. has the right to change the information, design, and construction of the product represented within the document without prior notice. For the most up-to-date product information, please go to www.DaikinApplied.com.

™@ Rebel, MicroTech, CORE, and Daikin Applied are trademarks or registered trademarks of Daikin Applied Americas Inc. The following are trademarks or registered trademarks of their respective companies: BACnet from American Society of Heating, Refrigerating and Air-Conditioning Engineers, Inc.; Echelon, LonWorks, LonMark, and LonTalk from Echelon Corporation; Modbus from Schneider Electric; and Windows from Microsoft Corporation.

Introduction

General Information

This manual provides general information about the "B" vintage Daikin Applied Rebel Commercial Packaged Rooftop Unit, model DPS. In addition to an overall description of the unit, it includes mechanical and electrical installation procedures, commissioning procedures, sequence of operation information, and maintenance instructions.

The MicroTech® rooftop unit controller is equipped on "B" vintage rooftop units. For operation and information on using and programming the MicroTech unit controller, refer to the appropriate operation manual (see [Table 1](#)).

For a description of operation and information on using the keypad to view data and set parameters, refer to the appropriate program-specific operation manual (see [Table 1](#)).

Table 1: Program Specific Unit Operation Literature

Controller Literature	Literature Number
Microtech Unit Controller for Rebel Rooftop Systems	OM 1382
Rooftop and Self Contained Unit Controller Protocol	ED 15112

Nomenclature (DPS 03–31)

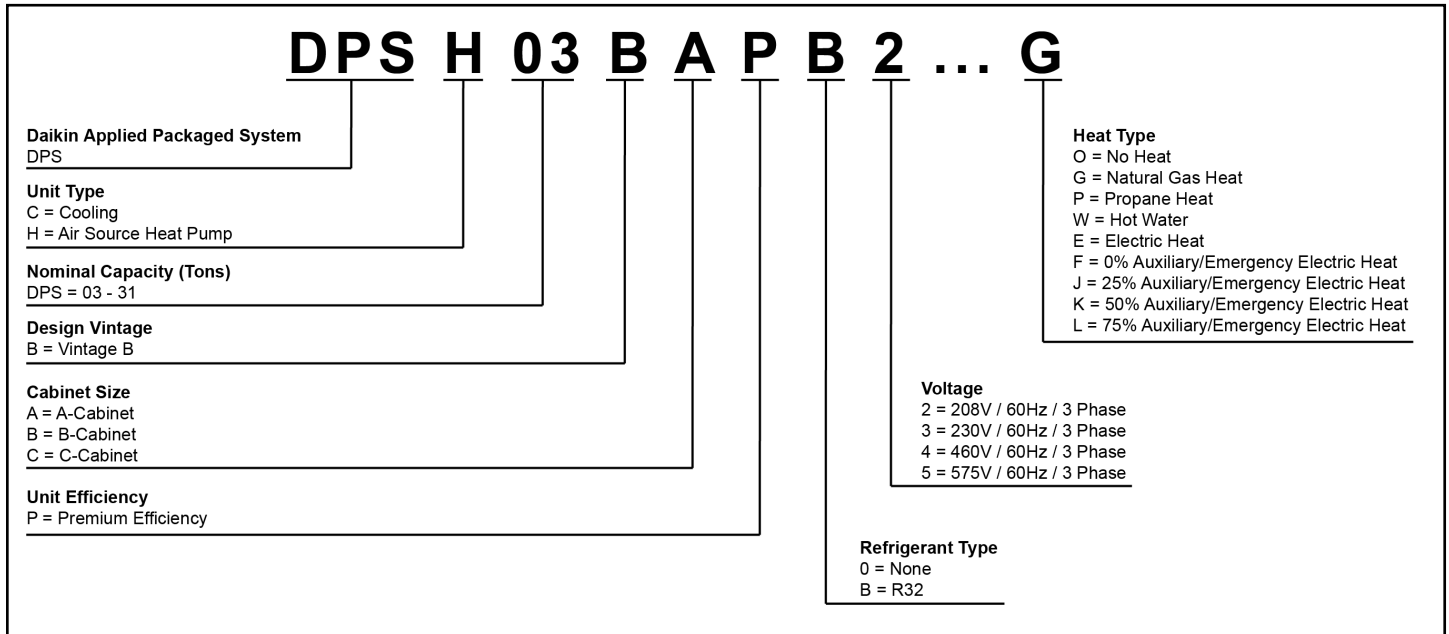

NOTE: "Heat Type" is represented by the 21st position in the code string.

Hazard Identification Information

⚠ DANGER

Dangers indicate a hazardous situation which will result in death or serious personal injury if not avoided.

⚠ WARNING

Warnings indicate potentially hazardous situations, which can result in property damage, severe personal injury, or death if not avoided.



⚠ CAUTION

Cautions indicate potentially hazardous situations, which can result in personal injury or equipment damage if not avoided.

NOTICE

Notice indicates practices not related to personal injury.

A2L Refrigerants

 WARNING	
 A2L	<p>This unit contains R-32, a class A2L refrigerant that is flammable. This unit should only be installed, serviced, repaired, and disposed of by qualified personnel licensed or certified in their jurisdiction to work with R-32 refrigerant. Installation and maintenance must be done in accordance with this manual. Improper handling of this equipment can cause equipment damage, personal injury, or equipment damage.</p>
<p>Be aware that R-32 refrigerant may not contain an odor. Place in a well ventilated area to prevent accumulation of refrigerant. When installing the unit in a small room, take measures to keep the refrigerant concentration from exceeding allowable safety limits. Excessive refrigerant leaks, in the event of an accident in a closed ambient space, can lead to oxygen deficiency.</p> <p>Do not pierce or burn this unit.</p> <p>Never use an open flame during service or repair. Never store in a room with continuously operating ignition sources (for example: open flames, an operating gas appliance, or an operating electric heater.), where there is ignitable dust suspension in the air, or where volatile flammables such as thinner or gasoline are handled.</p> <p>Only use pipes, nuts, and tools intended for exclusive use with R-32 refrigerant in compliance with national codes (ASHRAE15 or IRC).</p> <p>Do not mix air or gas other than R-32 in the refrigerant system. If air enters the refrigerant system, an excessively high pressure results, which may cause equipment damage or personal injury.</p> <p>Do not use means to accelerate the defrosting process or to clean, other than those recommended by the manufacturer.</p> <p>The unit shall be stored in a room without continuously operating ignition sources (for example: open flames, an operating gas appliance, or an operating electric heater).</p>	

 WARNING	
<p>When moving flammable A2L refrigerant to/from the unit from an auxiliary tank, a grounding strap must be used. An electrical charge builds when halocarbon refrigerant travels in a rubber hose. A grounding strap must be used between the auxiliary refrigerant tank and the unit's end sheet (earth ground), which will safely take the charge to the ground. A fire risk could occur if this procedure is not followed.</p>	

Gas Heat

 WARNING	
FIRE OR EXPLOSION HAZARD	
<p>LOCKOUT/TAGOUT all power sources prior to installing the gas furnace. Failure to follow warnings exactly could result in serious personal injury, death, or property damage. Be sure to read and understand the installation, operation, and service instructions within this manual. Improper installation, adjustments, alterations, service, or maintenance can cause serious personal injury, death, or property damage.</p> <p style="padding-left: 40px;">— Do not store or use gasoline or other flammable vapors or liquids in the vicinity of this appliance.</p>	
WHAT TO DO IF YOU SMELL GAS	
<ul style="list-style-type: none"> • Do not try to light any product that is fueled by or contains an open flame. • Do not touch any electrical switch. • Do not use any telephone in the building. • Leave the building immediately. • Immediately call the gas supplier from a remote telephone and follow the gas supplier's instructions. • If you cannot reach the gas supplier, call the local fire department or 911. <p style="padding-left: 40px;">— Installation and service must be performed by a qualified installer, service agency, or gas supplier.</p>	

 WARNING	
RISQUE D'INCENDIE OU D'EXPLOSION	
<p>Le non respect des mises en garde pourrait entraîner des blessures graves, la mort ou des pertes matérielles. Prendre soin de lire et de comprendre les instructions d'installation, de fonctionnement et d'entretien contenues dans ce guide. Une installation, un réglage, une modification, une réparation ou un entretien inapproprié peut entraîner des blessures graves, la mort ou des pertes matérielles.</p> <p style="padding-left: 40px;">— Ne pas entreposer ni utiliser d'essence ou autre vapeurs ou liquides inflammables à proximité de cet appareil ou de tout autre appareil.</p>	
QUE FAIRE SI VOUS SENTEZ UNE ODEUR DE GAZ	
<ul style="list-style-type: none"> • Ne tentez pas d'allumer un appareil. • Ne touchez pas à un interrupteur; n'utilisez pas de téléphone dans l'édifice ou vous trouvez. • Sortez de l'édifice immédiatement. • Appelez immédiatement le fournisseur de gaz à partir d'un téléphone à l'extérieur de l'édifice. Suivez les instructions du fournisseur de gaz. • Si vous ne pouvez joindre le fournisseur de gaz, appelez les pompiers. <p style="padding-left: 40px;">— L'installation et les réparations doivent être confiées à un installateur qualifié ou au fournisseur de gaz.</p>	

Unit Nameplate

The unit nameplate is located on the outside of the main control box door. It includes the unit model number, serial number, electrical characteristics, and refrigerant charge.

Compliance Statements







Depending on the unit configuration, the unit will come with either a Fused Disconnect, a Non-Fused Disconnect, a power block, or a combination in cases where multiple sources of power are specified. Consult the Unit Specific Electrical Schematics to determine the number of required sources of power. Refer to [page 33](#) for the standard multiple point power connection options and their function.

Children should be supervised to ensure that they do not play with the appliance.

This appliance is not intended for use by persons (including children) with reduced physical, sensory, or mental capabilities, or lack of experience and knowledge, unless they have been given supervision or instruction concerning use of the appliance by a person responsible for their safety.

Unit Labels

Pictogram warning and informational labels may be present on the unit. Consult the table below for reference.

Label	Description
 <p>Refrigerant class per ISO 817</p>	<p>WARNING - flammable refrigerant present</p>
	<p>Read the technical manual for service instructions</p>
	<p>WARNING - A2L low-burning velocity refrigerant present</p>
	<p>Pressurized medium present</p>
	<p>Ultraviolet (UV) radiation present</p>
	<p>Read the technical manual for instructions</p>

Mechanical Installation

Installer Responsibilities

CAUTION

Sharp edges on sheet metal and fasteners can cause personal injury. This equipment must be installed, operated, and serviced only by an experienced installation company and fully trained personnel.

The installation of this equipment shall be in accordance with the regulations of authorities having jurisdiction and all applicable codes. It is the responsibility of the installer to determine and follow the applicable codes.

NOTICE

Unit/equipment must be installed in a location that is not accessible to the general public.

Receiving and Handling

Carefully check equipment against the bill of lading to ensure all items have been received. Before unloading any unit, check the nameplate to make sure the voltage complies with the power supply available.

Inspect all units for damage upon arrival. If a unit has become dirty during shipment, carefully clean it prior to completing the inspection. Daikin Applied is not responsible for physical damage after the unit leaves the factory unless the contract with Daikin Applied states otherwise.

NOTICE

All units should be carefully inspected for damage when received. Report all loss or shipping damage using a claim form supplied by Daikin Applied.

VISIBLE LOSS OR DAMAGE: Any external evidence of loss or damage must be noted on the freight bill or carrier's receipt, and signed by the carrier's agent. Failure to adequately describe such external evidence of loss or damage may result in the carrier's refusal to honor a damage claim.

CONCEALED LOSS OR DAMAGE: Concealed loss or damage means loss or damage which does not become apparent until the unit has been unpacked or unwrapped. The contents may be damaged in transit due to rough handling even though the exterior may not show damages. When the damage is discovered, make a written request for inspection by the carrier's agent within **five (5) days** of the delivery date and file a claim with the form provided by Daikin Applied. Refer to the Daikin Applied Freight Policy for further information.

Service Clearance

CAUTION

Location. Care should be taken for the installation location to minimize snow drifts on the outdoor coil.

Allow service clearances as approximately indicated in [Figure 1](#). Also, Daikin Applied recommends providing a roof walkway to the rooftop unit as well as along each side of the unit that provides access to most controls and serviceable components.

Refer to NEC and local code for minimum clearances around the unit and control panel.

Reasons for clearance:

1. Door swings – all hinged access doors need space to freely swing to accommodate standard service, such as filter replacement.
2. Components pulls – if a component such as an energy recovery wheel fails, space to the side of the unit is needed to allow for full removal.
3. Condenser flow – packaged equipment reject heat via proper airflow pulled across the condenser coil. If airflow is restricted, the unit may not operate properly.
4. Air recirculation – whether it is the building exhaust or gas burner flue, there is a required clearance to allow those undesired airstreams from approaching the outdoor intake.
5. Pertinent codes – whether it is an electrical or other code, many municipalities dictate minimum clearances around powered devices.

Pre-Construction

The Rebel unit comes equipped with a Microtech unit controller and can be used for sites that are still under construction. The following conditions must be met.

1. Ductwork has to be installed. The fan proving switch and furnace might not run correctly without the specified external static pressure.
2. Filters must be installed.
3. Follow furnace commissioning instructions found in the furnace section.
4. After substantial completion of the construction process the unit is to be thoroughly cleaned. Special attention should be paid to the indoor DX coil and the furnace. Filters should be changed.
5. Furnace operation, rate, and temperature rise should be verified. See instructions found in the furnace section.

Lab Pressurization Applications

1. Install a "T" fitting with a leak-tight removable cap in each tube near the sensor fitting. This facilitates connecting a manometer or pressure gauge if testing is required.
2. Use different colored tubing for the controlled space pressure (high) and reference pressure (low) taps, or tag the tubes.
3. Regardless whether the controlled space is positive or negative with respect to its reference, locate the high pressure tap in the controlled space (the setpoint can be set between -0.2" and 0.2" WC).
4. Locate the reference pressure (low) tap in the area surrounding the controlled space. Not locating the reference tap to the sensor results in unsatisfactory operation.
5. Locate both taps so they are not influenced by any source of moving air (velocity pressure). These sources may include air diffusers or doors between the high and low pressure areas.

- Route the building tap tube between the curb and the supply duct and feed it into the unit through the knockout in the bottom of the control panel.
- Connect the tube to the (high) fitting for sensor SPS2.

Factory Recommended Clearances

The clearance values shown in [Figure 1](#), [Figure 2](#), and [Figure 3](#) are the tested values that Daikin Applied has established will provide enough room to service and allow units to function. Technicians that elect to deviate from the recommended clearances as demonstrated shall do so at their own risk. In the event that the recommended clearances are waived, special consideration should be given to:

- Condenser ventilation
- Door swings
- Service/Removal of internal components
- Gas heat flue exhaust ventilation
- Outside air intake ventilation
- Control panel National Electrical Code (NEC) required clearance

NOTE: Outside air coil can be pulled from any side of the condenser section or through the roof of the unit.

Table 2: Standard Service Clearance Recommendations

See Figure 1, Figure 2, and Figure 3			
Dimension	Unit Size		
	03-06	07-17	16-31
A	60 in (1524mm)	36 in (914mm)	50 in (1270mm)
B	50 in (1270mm)	60 in (1524mm)	60 in (1524mm)
C	36 in (914mm)	50 in (1270mm)	60 in (1524mm)
D	48 in (1219mm)		80 in (2302mm)

Ventilation Clearance

Below are minimum ventilation clearance recommendations. The system designer must consider each application and provide adequate ventilation. If this is not done, the unit may not perform properly.

Unit(s) Surrounded by a Screen or a Fence:

- The bottom of the screen or fence should be at least 1 ft. (305 mm) above the roof surface.
- The distance between the unit and a screen or fence should be as described in [Figure 1](#), [Figure 2](#), and [Figure 3](#).
- The distance between any two units within a screen or fence should be at least 120" (3048 mm).

Unit(s) Surrounded by Solid Walls:

- If there are walls on one or two adjacent sides of the unit, the walls may be any height. If there are walls on more than two adjacent sides of the unit, the walls should not be higher than the unit.
- The distance between the unit and the wall should be at least 96" (2438 mm) on all sides of the unit.
- The distance between any two units within the walls should be at least 120" (3048 mm).

Do not locate outside air intakes near sources of contaminated air.

If the unit is installed where windy conditions are common, install wind screens around the unit, maintaining the clearances specified (see [Figure 1](#), [Figure 2](#), and [Figure 3](#)). This is particularly important to maintain adequate head pressure control when mechanical cooling is required at low outdoor air temperatures.

Overhead Clearance

- Unit(s) surrounded by screens or solid walls must have no overhead obstructions over any part of the unit. For heat pump models overhead obstructions could allow the formation of dangerous icicles.
- The area above the condenser must be unobstructed in all installations to allow vertical air discharge.
- The following restrictions must be observed for overhead obstructions above the air handler section:
 - There must be no overhead obstructions above the furnace flue, or within 9" (229 mm) of the flue box.
 - Overhead obstructions must be no less than 96" (2438 mm) above the top of the unit.
 - There must be no overhead obstructions in the areas above the outside air and exhaust dampers that are farther than 24" (610 mm) from the side of the unit.

Figure 1: A-Cabinet Service Clearances (03-06)

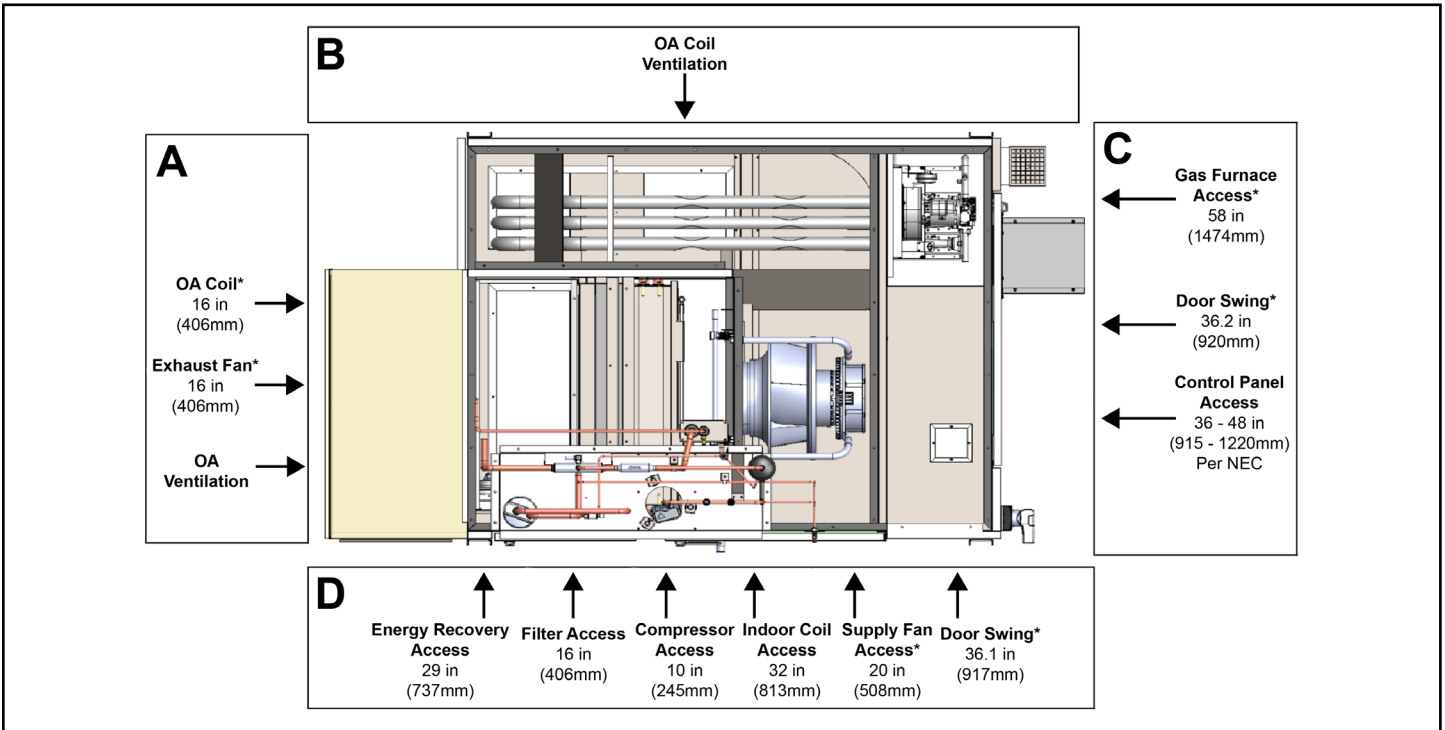

NOTE: A, B, C, and D dimensions shown in Table 2 on page 7.

NOTE: *Denotes clearance recommended for largest component size offered. Smaller versions may require less clearance.

Figure 2: B-Cabinet Service Clearances (07-17)

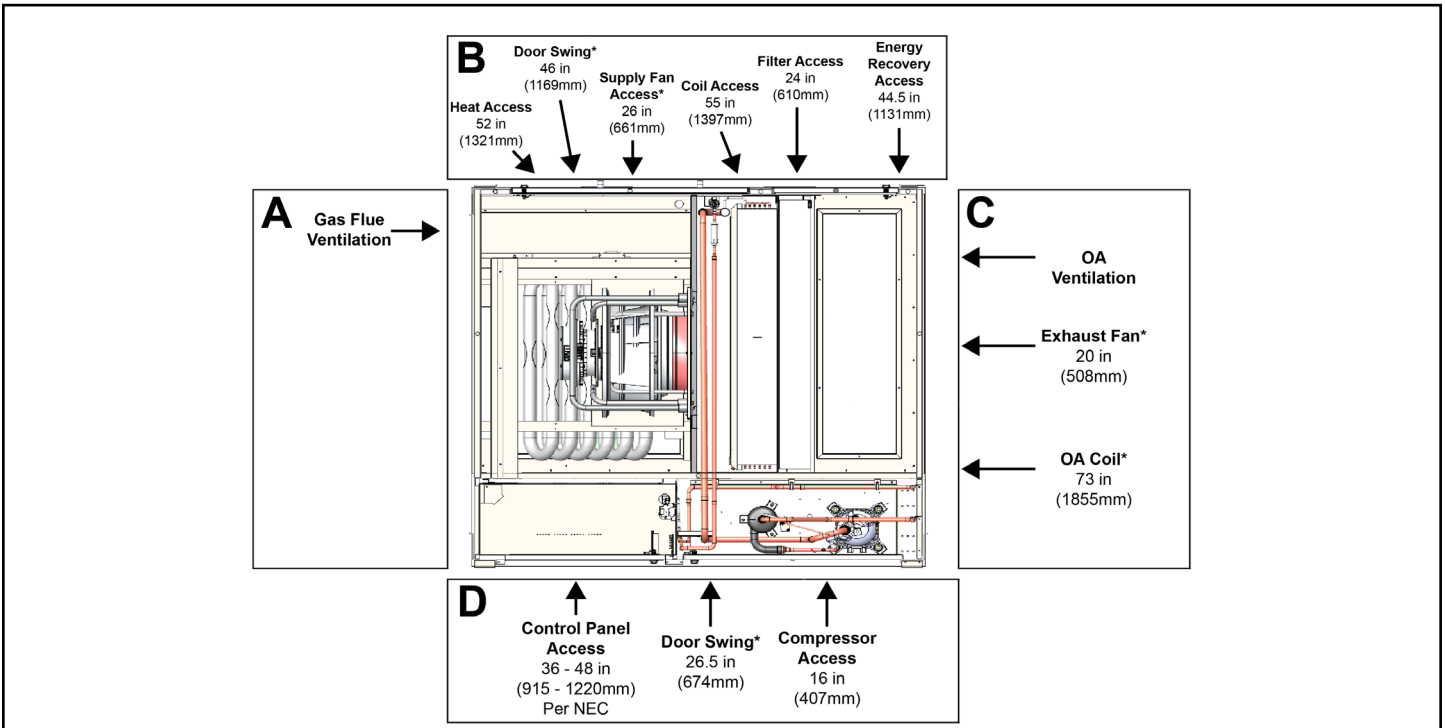

NOTE: A, B, C, and D dimensions shown in Table 2 on page 7.

NOTE: *Denotes clearance recommended for largest component size offered. Smaller versions may require less clearance.

Figure 3: C-Cabinet Service Clearances (16-31)

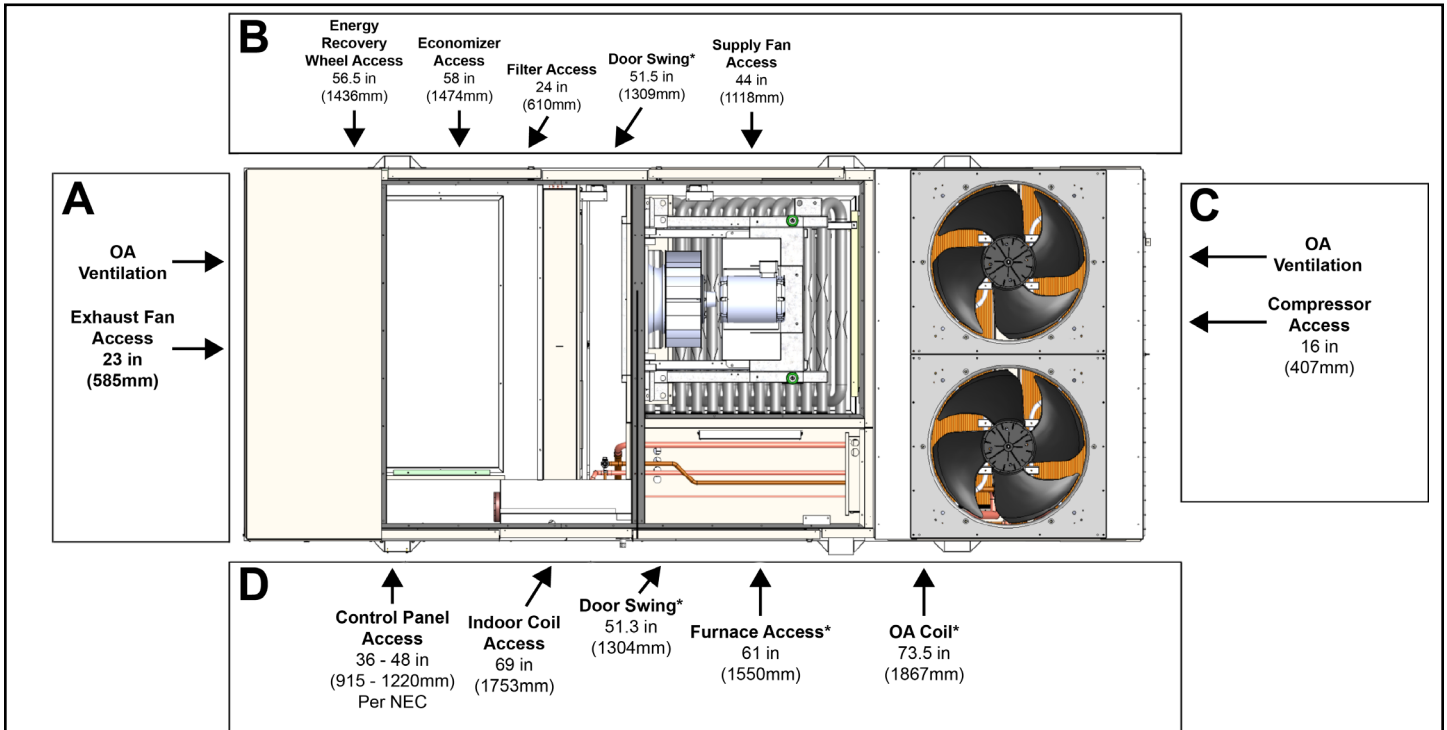

NOTE: A, B, C, and D dimensions shown in Table 2 on page 7.

NOTE: *Denotes clearance recommended for largest component size offered. Smaller versions may require less clearance.

Figure 4: A Cabinet WITH Energy Recovery Wheel Door Swings (03-06)

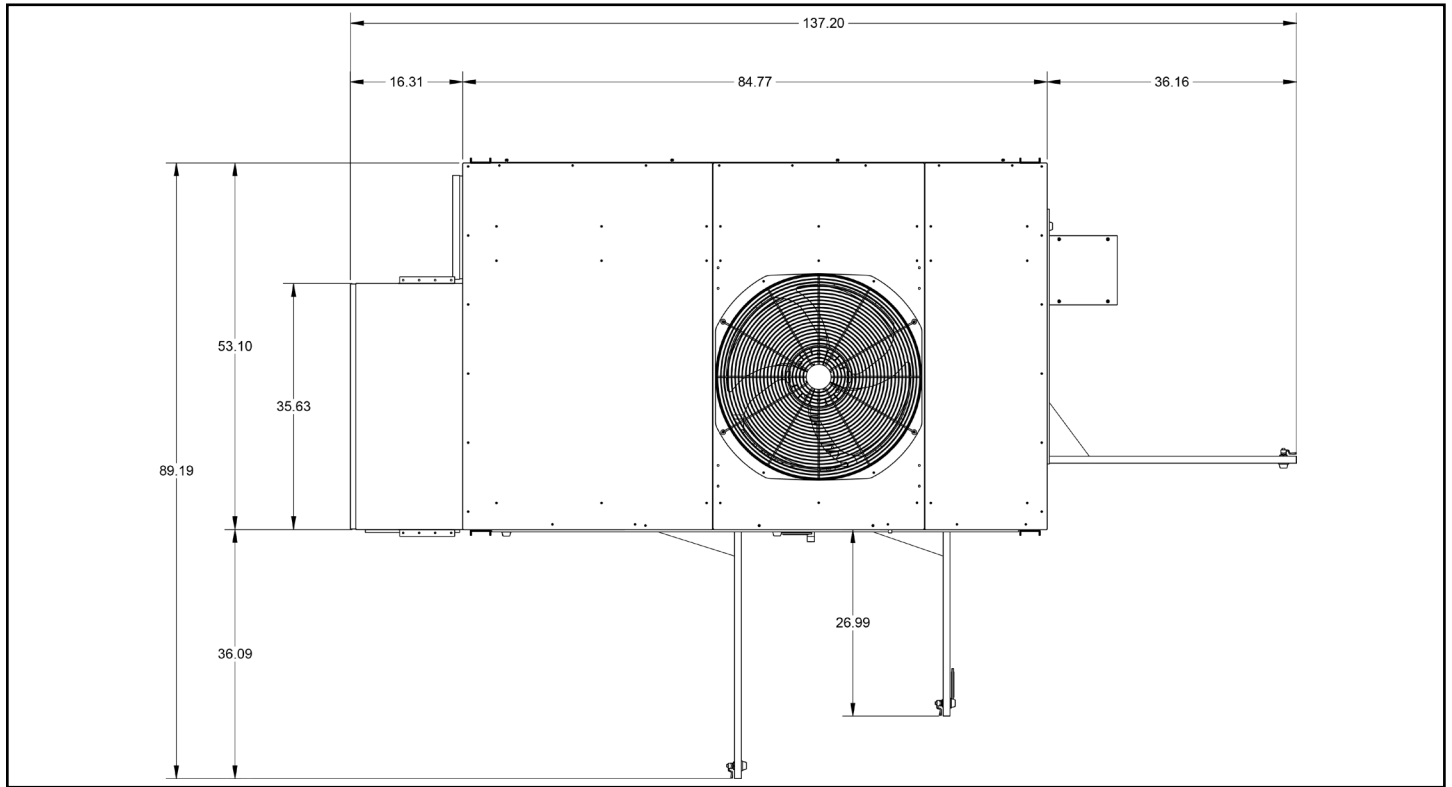

Figure 5: A Cabinet WITHOUT Energy Recovery Door Swings (03-06)

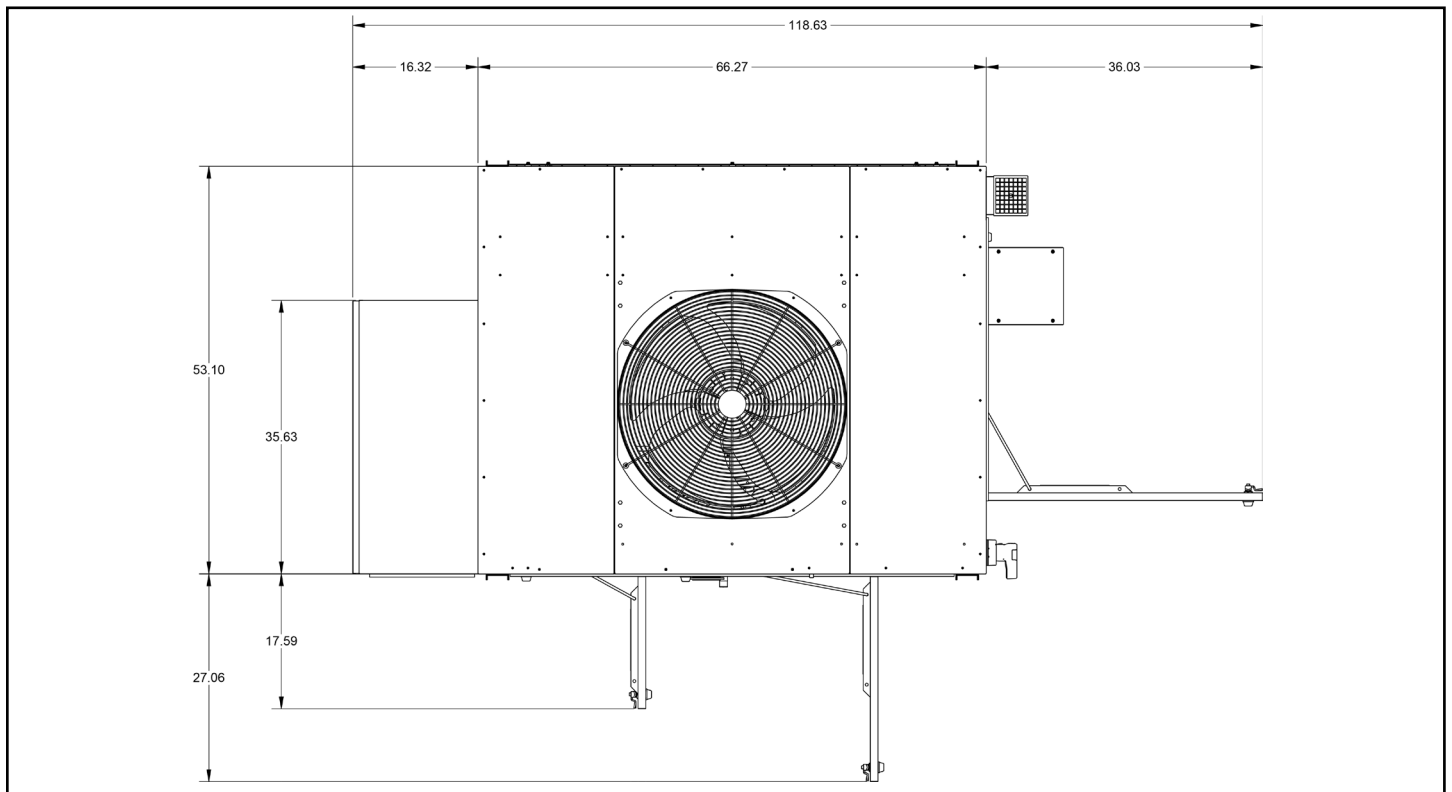

Figure 6: B Cabinet WITH Energy Recovery Wheel Door Swings (07-17)

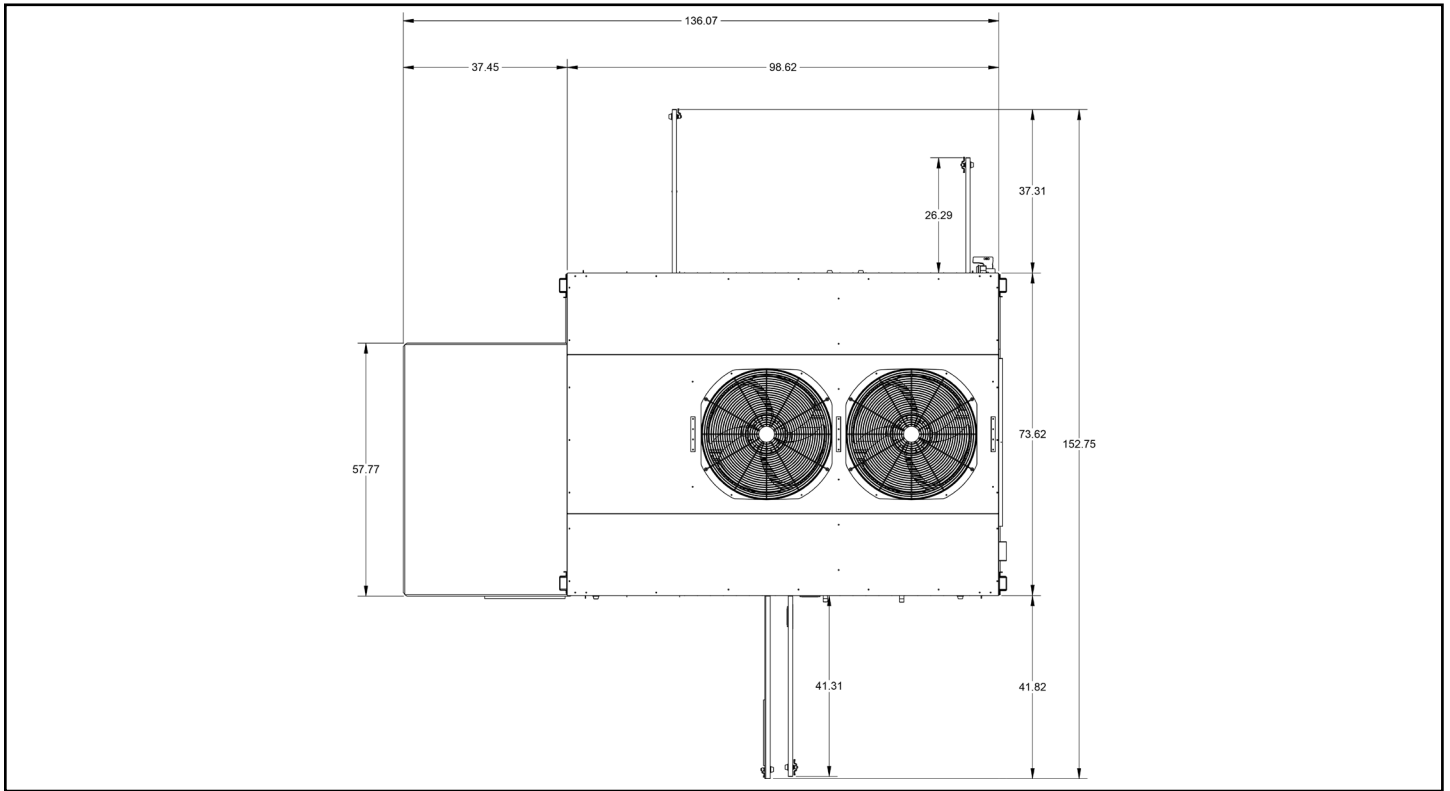

Figure 7: B Cabinet WITH Fixed Plate Heat Exchanger Door Swings (07-17)

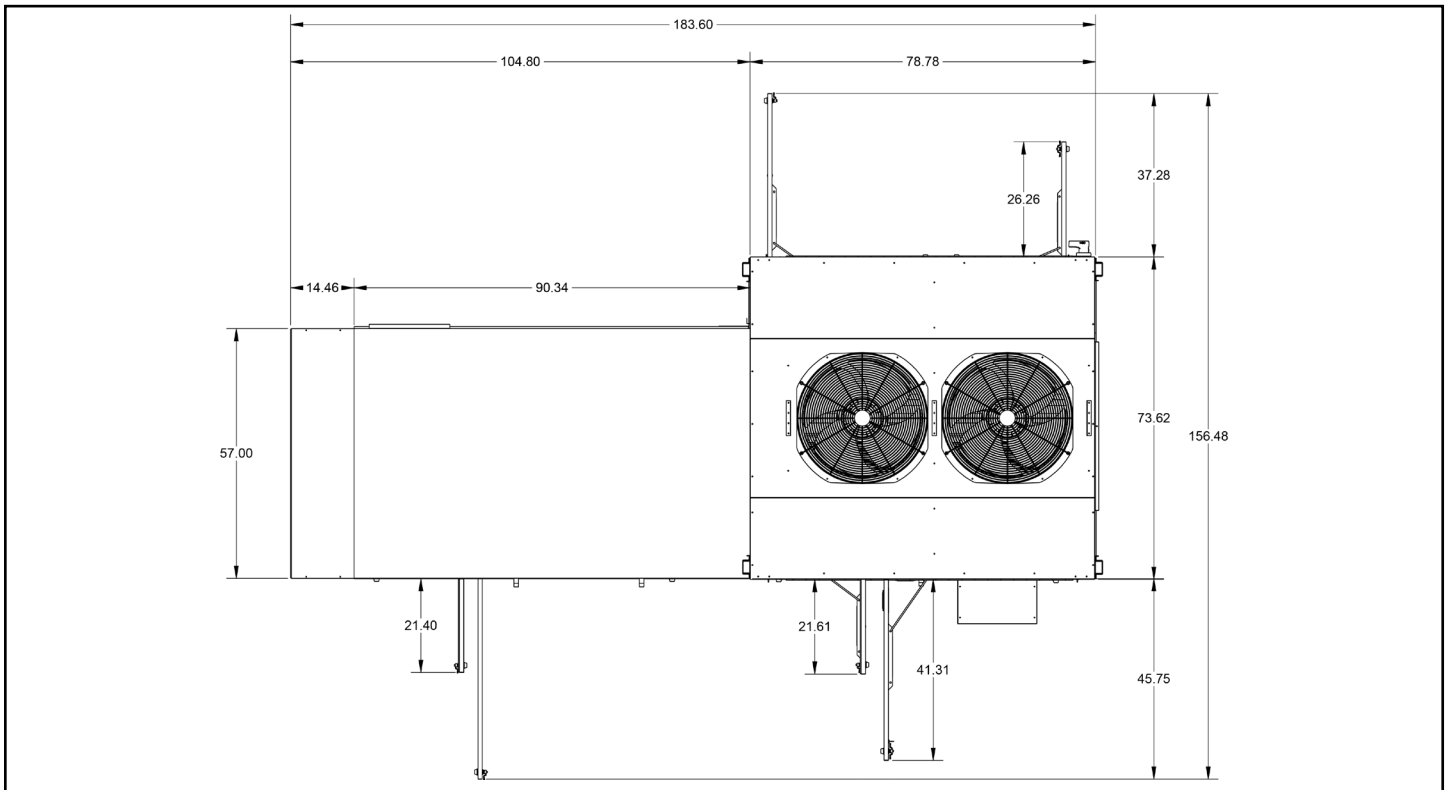

Figure 8: B Cabinet WITHOUT Energy Recovery Wheel Door Swings (07-17)

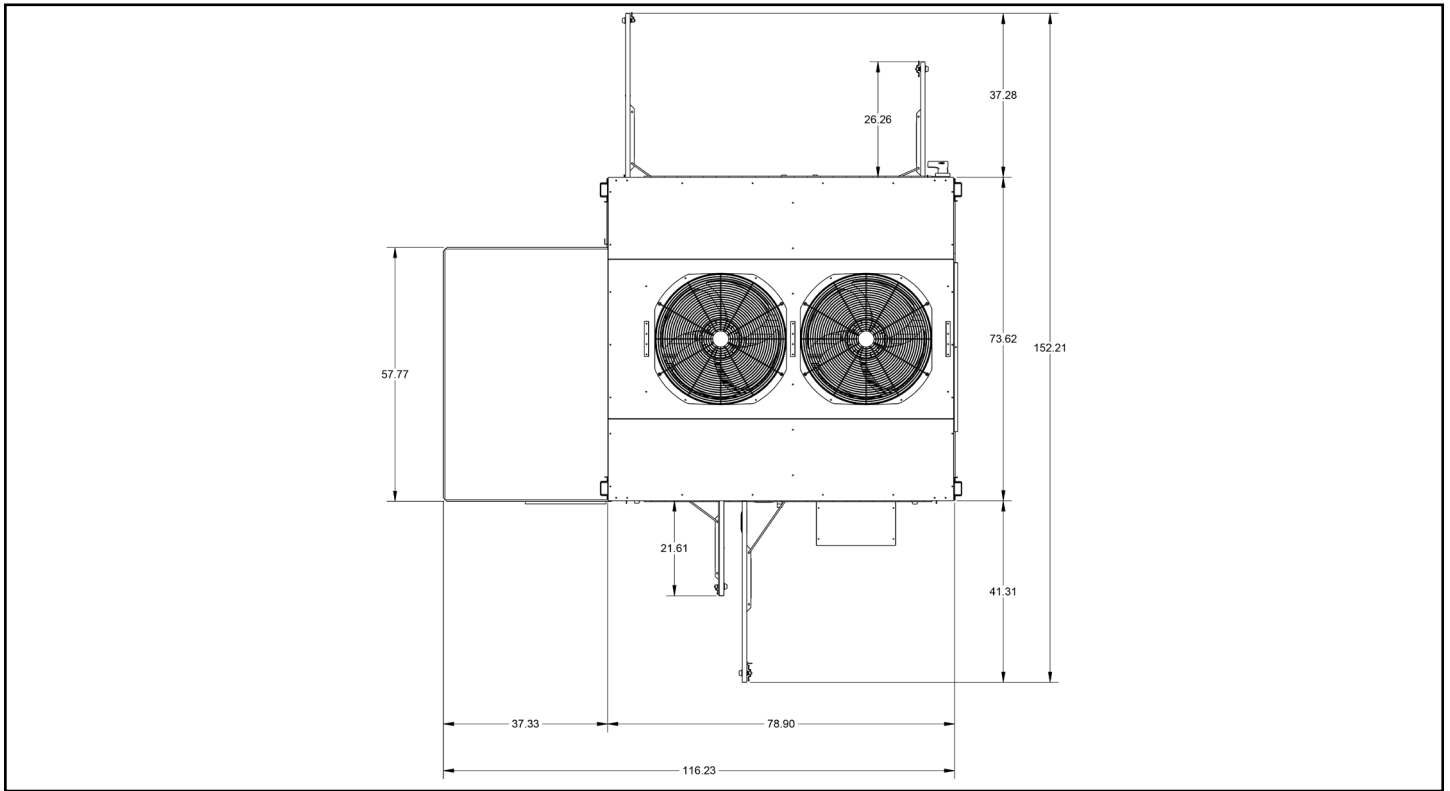

Figure 9: C Cabinet WITH Energy Recovery Wheel Door Swings (16-31)

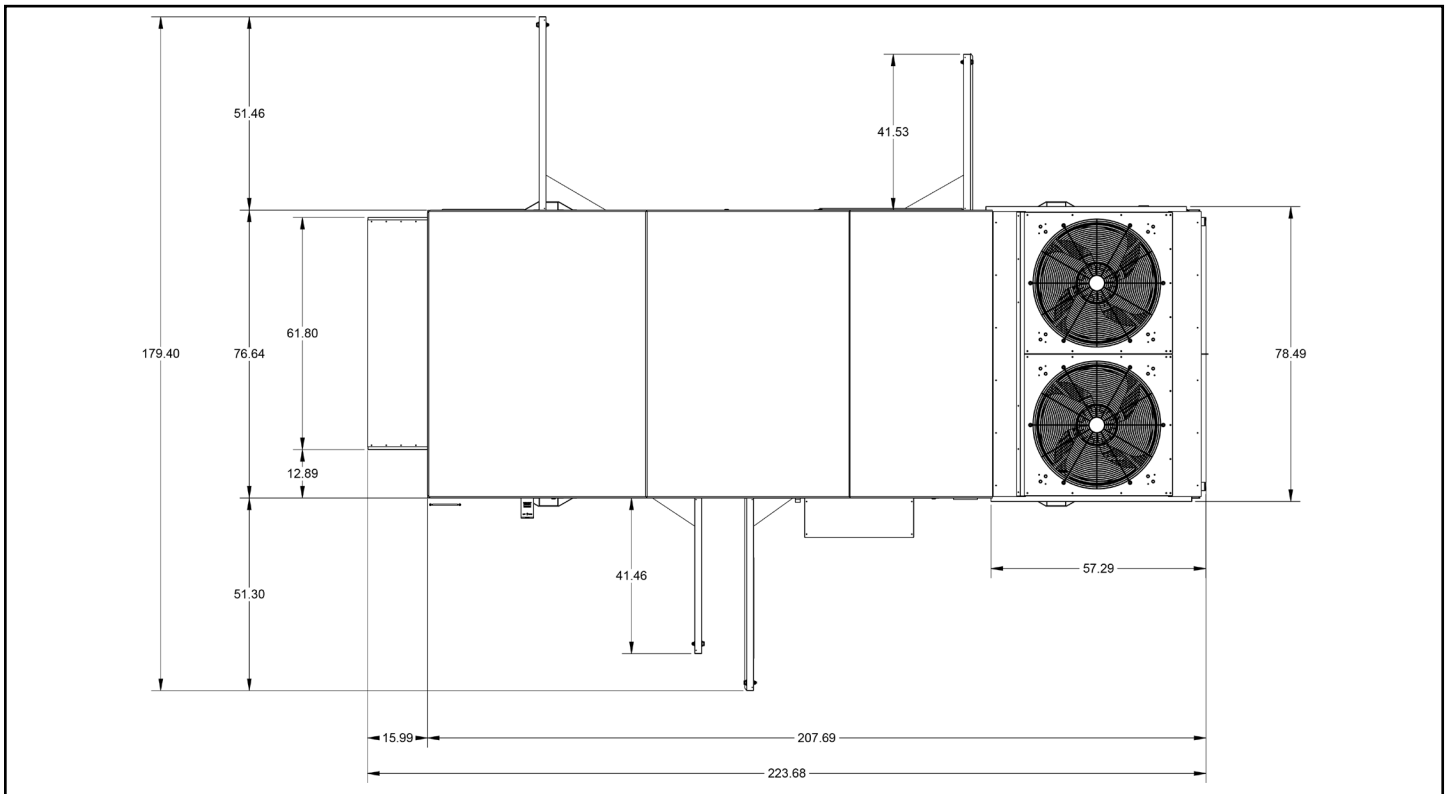

Figure 10: C Cabinet WITH Fixed Plate Heat Exchanger Door Swings (16-31)

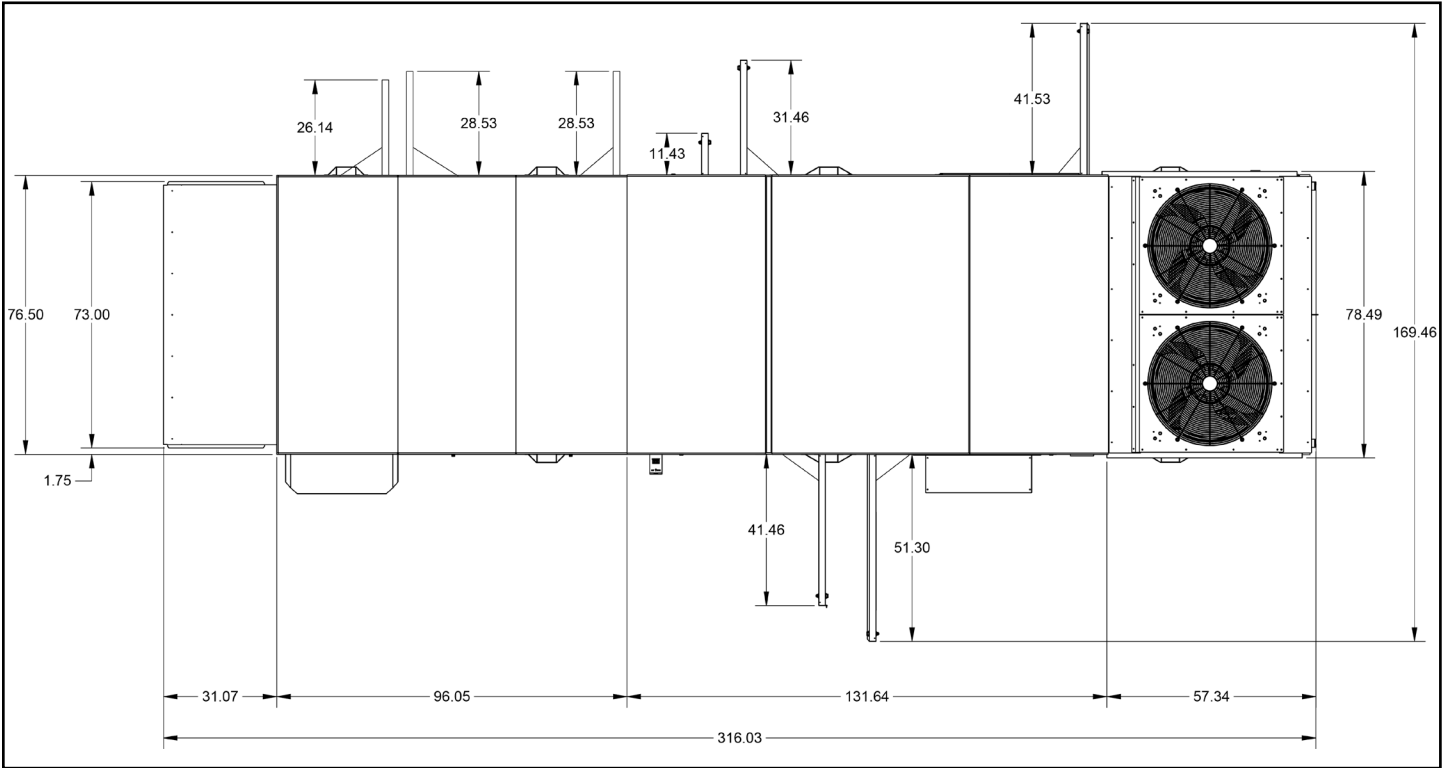
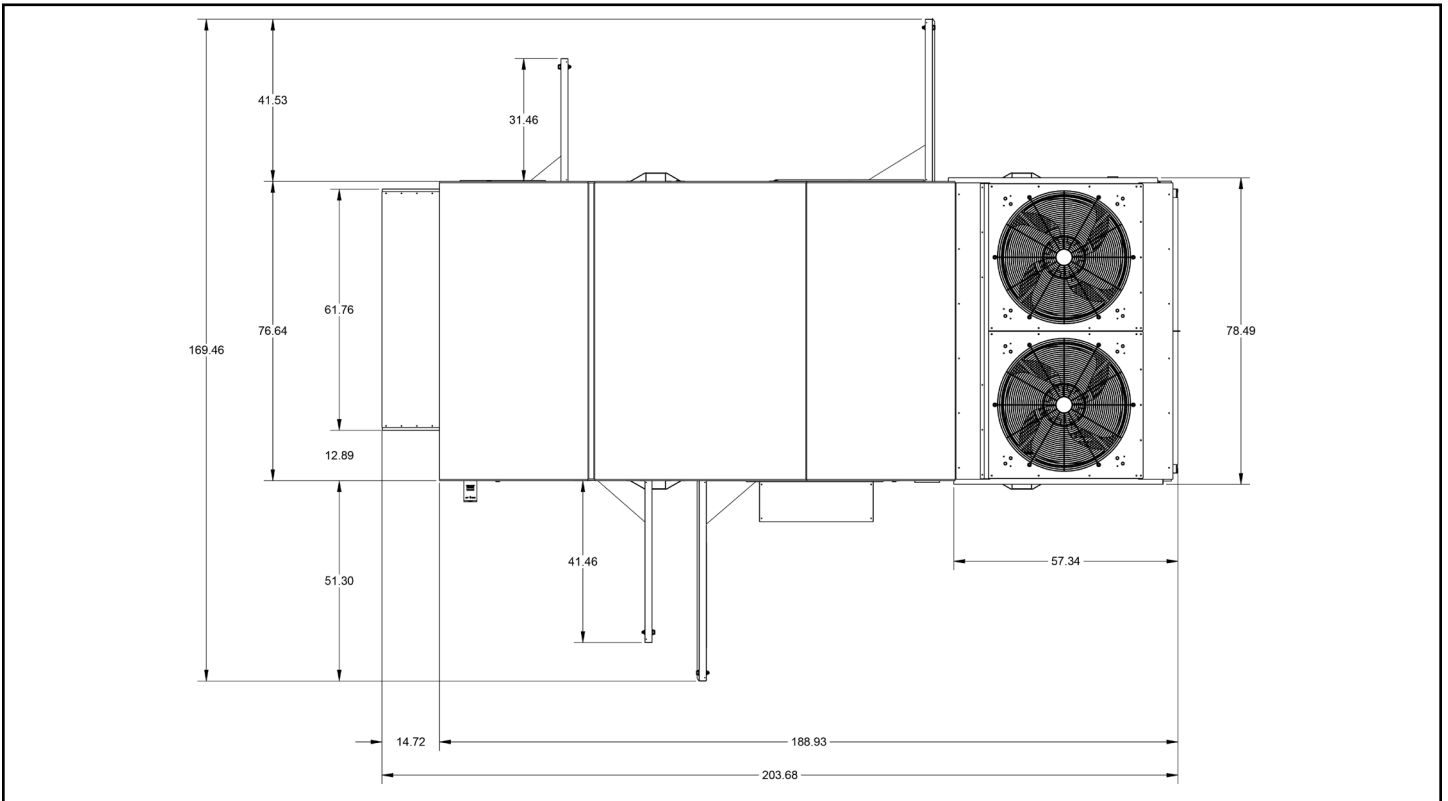

Figure 11: C Cabinet WITHOUT Energy Recovery Wheel Door Swings (16-31)



Steel Rail Installation

Rebel units may be mounted directly on steel support beams. Verify that the structure has the ability to properly support the weight of the unit. Support must be around the entire perimeter of the air handling section with the base of the unit centered and completely supported.

Rebel units DPS 016 – 31 must be supported for the entire base perimeter including the condenser section.

Daikin Applied does allow welding of the base of the unit directly to the structural steel supports.

Post and Rail Mounting

CAUTION

The unit must be level side to side and over the entire length. Equipment damage can result if the unit is not level.

For DPS 016 - 31 units, when mounting by post and rail, run the structural support the full length of the unit. Locate the structural member at the base of the unit as shown in Figure 12, assuring the I-beam is well supported by the structural member.

If resilient material is placed between the unit and the rail, insert a heavy steel plate between the unit and the resilient material to distribute the load. Seal cabinet penetrations (electrical, piping, etc.) properly to protect against moisture and weather.

Figure 12: Post and Rail Mounting

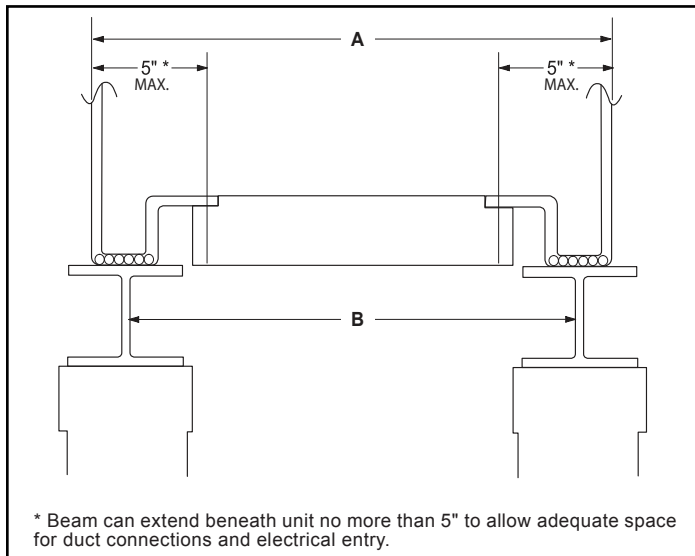

Table 3: Post and Rail Mounting Dimensions

DPS 016 - 31			
Dimension	Standard	Energy Recovery Wheel	Flat-Plate Heat Exchanger
A (length)	162.30	182.30	259.00
B (length)	160.73	180.73	257.43
A (width)	76.50	76.50	76.50
B (width)	74.93	74.93	74.93

Roof Curb Assembly and Installation

WARNING

Mold can cause personal injury. Some materials such as gypsum wall board can promote mold growth when damp. Such materials must be protected from moisture that can enter units during maintenance or normal operation.

Locate the roof curb and unit on a portion of the roof that can support the weight of the unit. The unit must be supported to prevent bending or twisting of the machine.

If building construction allows sound and vibration into the occupied space, locate the unit over a non-critical area. It is the responsibility of the system designer to make adequate provisions for noise and vibration in the occupied space.

Install the curb and unit level to allow the condensate drain to flow properly and allow service access doors to open and close without binding.

The gasketed top surface of the curb seals against the unit when it is set on the curb. These flanges must not support the total weight of the duct work. See [Installing Ductwork on page 29](#) for details on duct connections. It is critical that the condensate drain side of the unit be no higher than the opposite side.

Assembly Instructions

Assembly of a typical roof curb is shown in the diagrams beginning on [page 15](#).

1. Set curbing parts A through J per dimensions shown over roof opening or on a level surface. Note location of supply air opening. Check alignment of all mating screw holes.
2. Screw curbing parts together using fasteners provided. Leave all screws loose until curb is checked to be square.
3. Square entire curbing assembly and securely tighten all screws.
4. Position curb assembly over roof openings. Curb must be level within 0.25 inches from side to side and 1.50 inches over its length. Check that top surface of curb is flat with no bowing or sagging.
5. Weld curb assembly in place. Caulk all seams watertight. Remove backing from 0.25 × 1.50 wide gasket and apply to surfaces shown by crosshatching.
6. Check that electrical connections are coordinated and installed in accordance with all applicable local and NEC codes.

NOTICE

For all roof curb assembly and dimensioned drawings:

1. Check submittal drawing for gas/water/electrical/supply/return air opening.
2. Horizontal above the roof gas connection only.
3. All dimensions are shown in inches.

Table 4: Curb Weights

Curb Weights		
Configuration (Sizes)	14 in	24 in
Standard A Cabinet (DPS 03-06)	88 lbs	116 lbs
A Cabinet with ERW (DPS 03-06)	107 lbs	140 lbs
Standard B cabinet (DPS 07-17)	118 lbs	150 lbs
B Cabinet with ERW (DPS 07-17)	141 lbs	179 lbs
B Cabinet with FPHE (DPS 07-17)	214 lbs	272 lbs
Standard C Cabinet (DPS 16-31)	255 lbs	323 lbs
C Cabinet With ERW (DPS 16-31)	271 lbs	344 lbs
C Cabinet with FPHE (DPS 16-31)	300 lbs	500 lbs

Figure 13: Roof Curb Assembly (DPS 03 - 06)

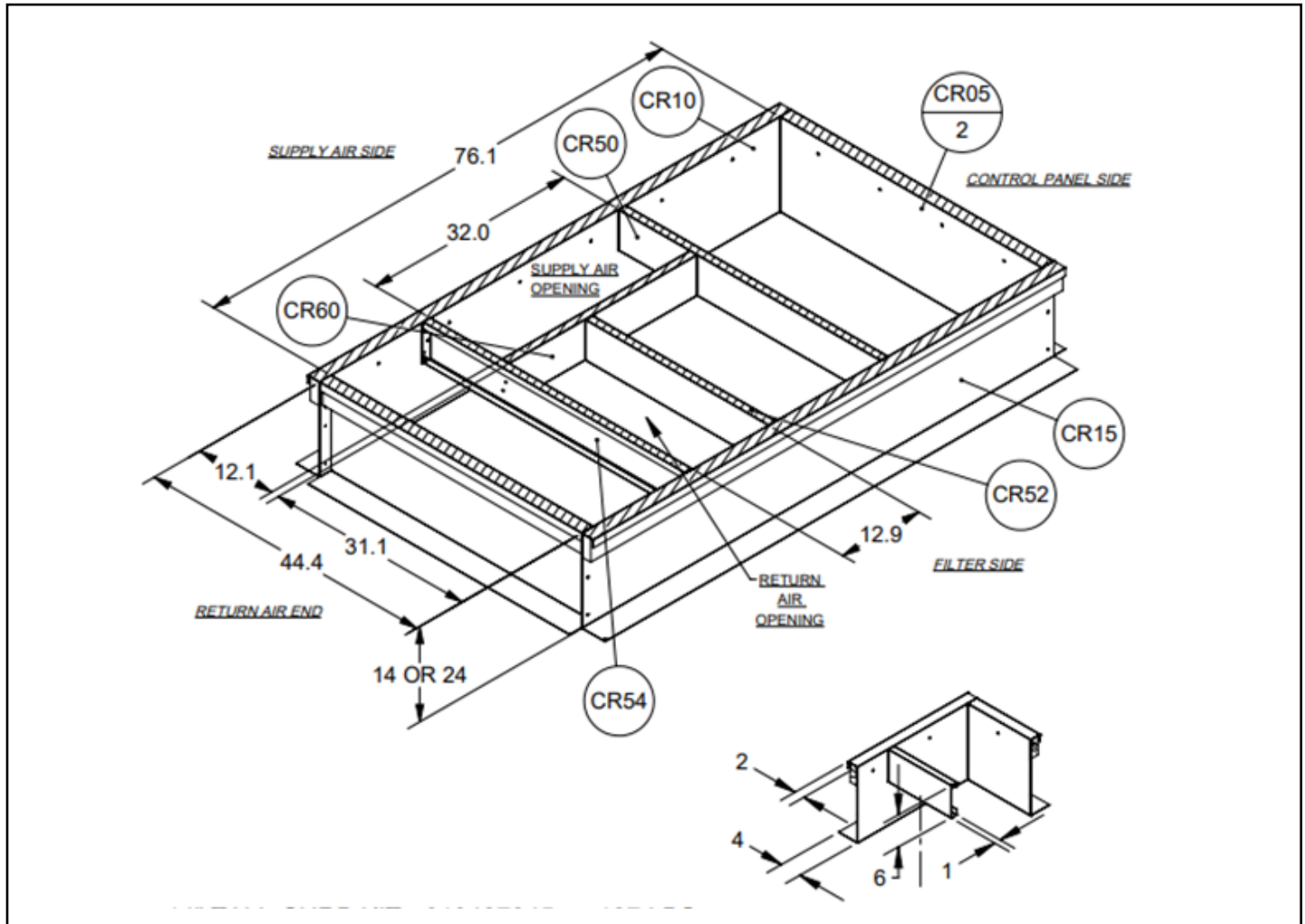

Figure 14: Standard Roof Curb Dimensions – (DPS 03 - 06)

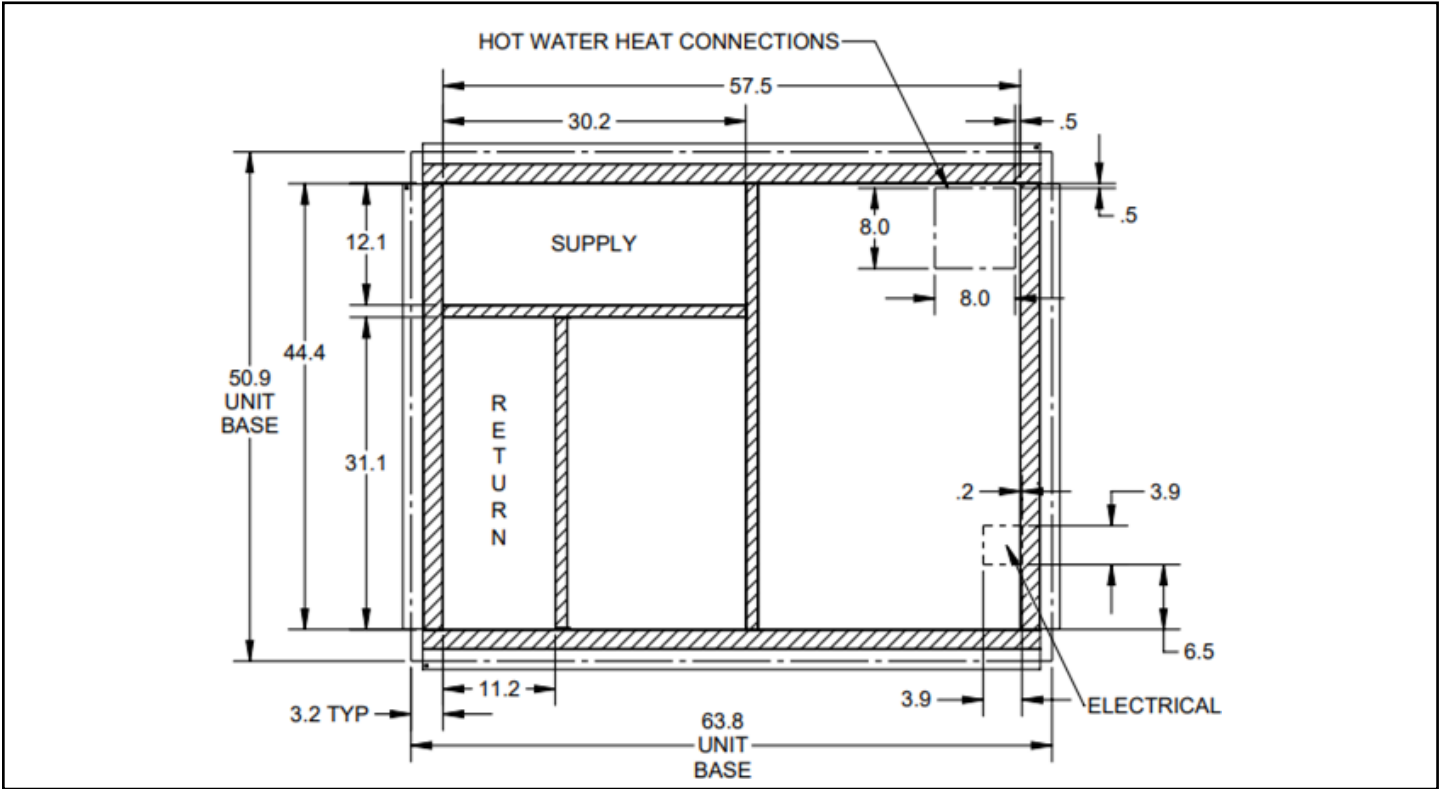

Figure 15: Roof Curb for ERW Dimensions – (DPS 03 - 06)

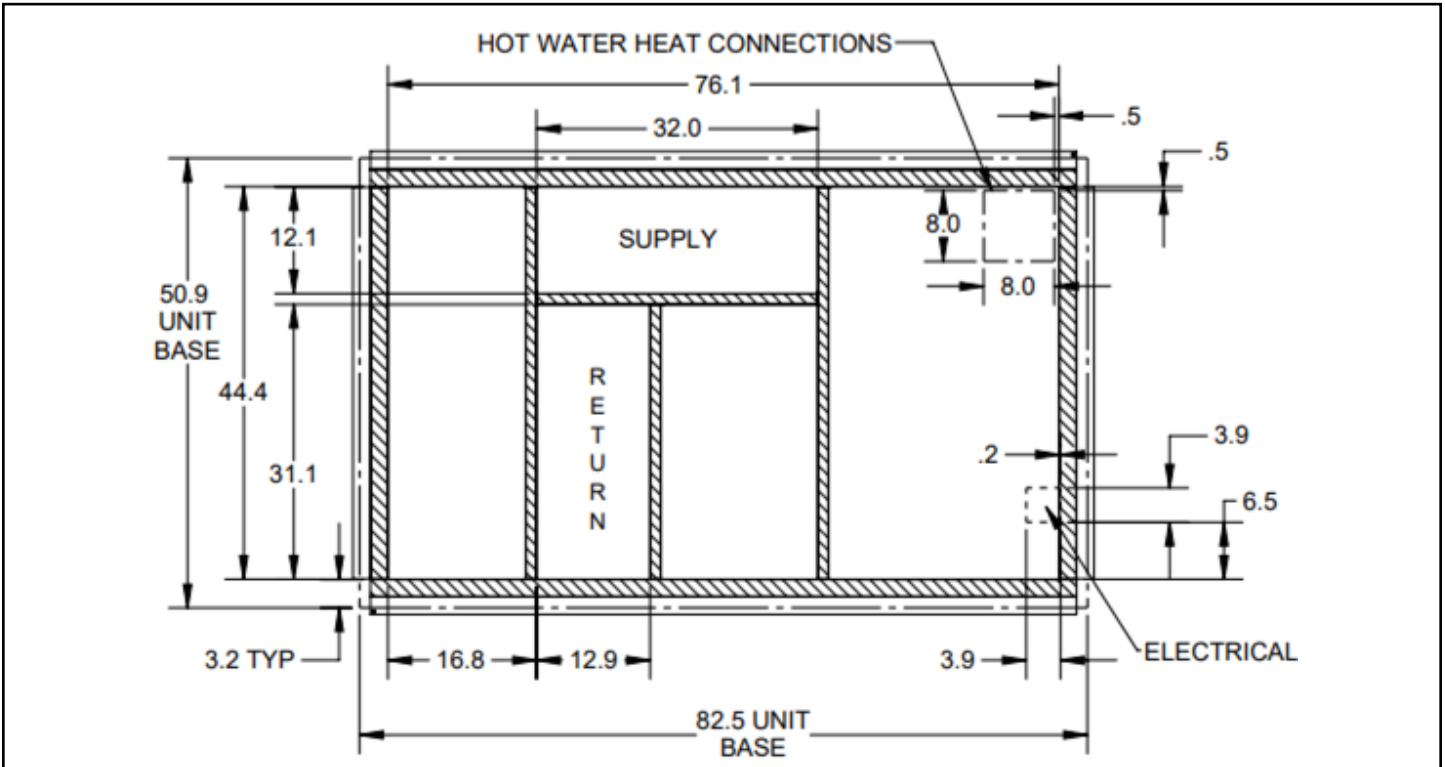

Figure 16: Standard Roof Curb Assembly (DPS 07-17)

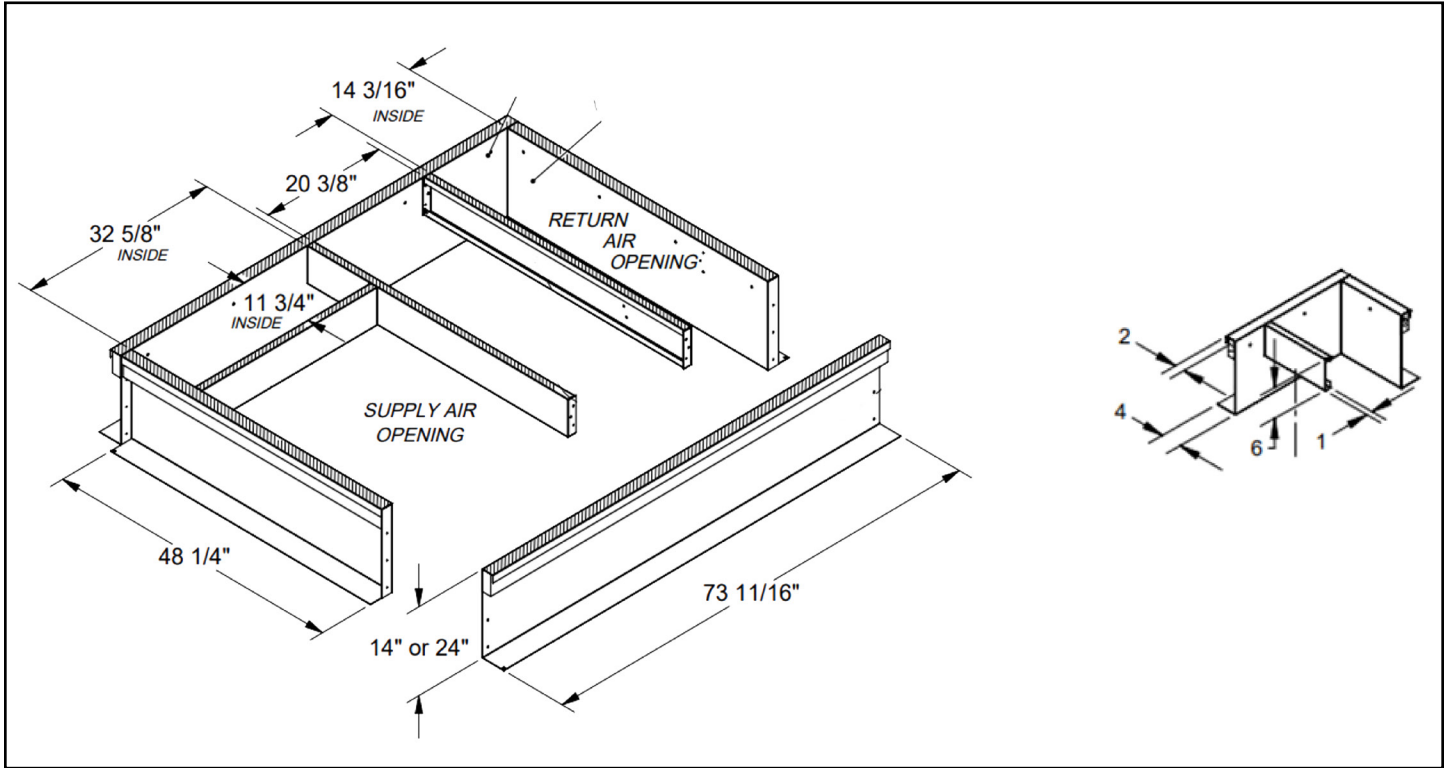

Figure 17: Standard Roof Curb Dimensions (DPS 07-17)

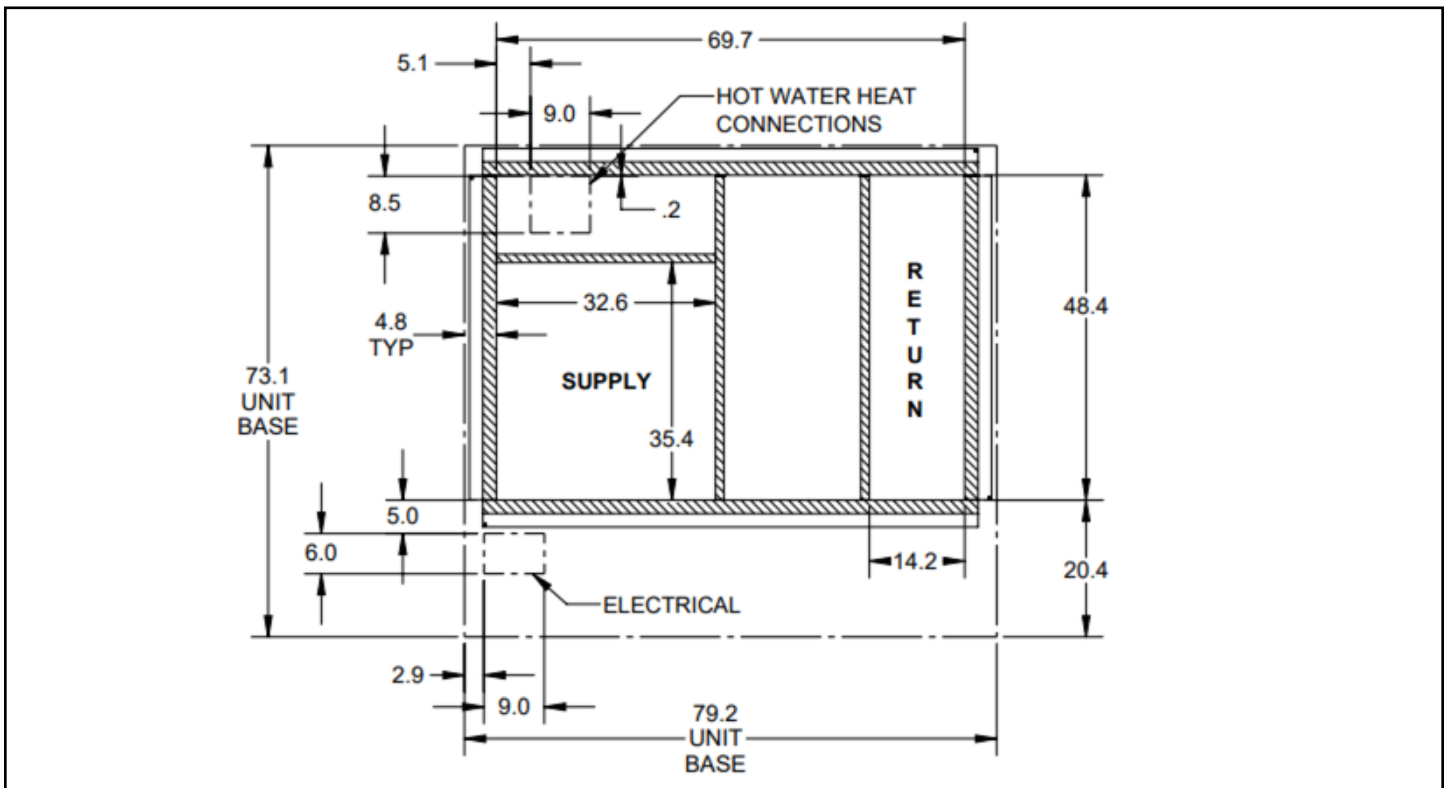

Figure 18: Roof Curb Assembly with ERW (DPS 07-17)

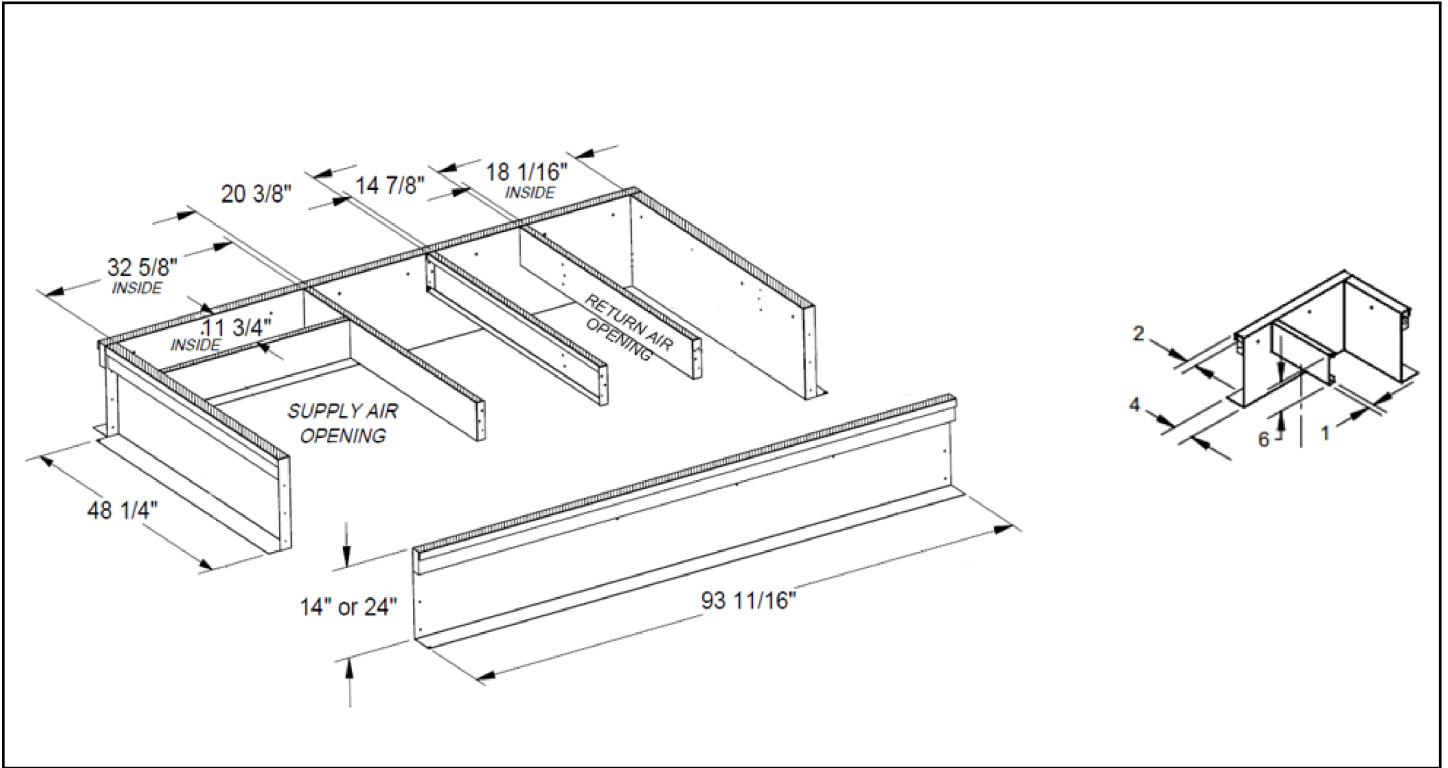

Figure 19: Roof Curb Dimensions with ERW (DPS 07-17)

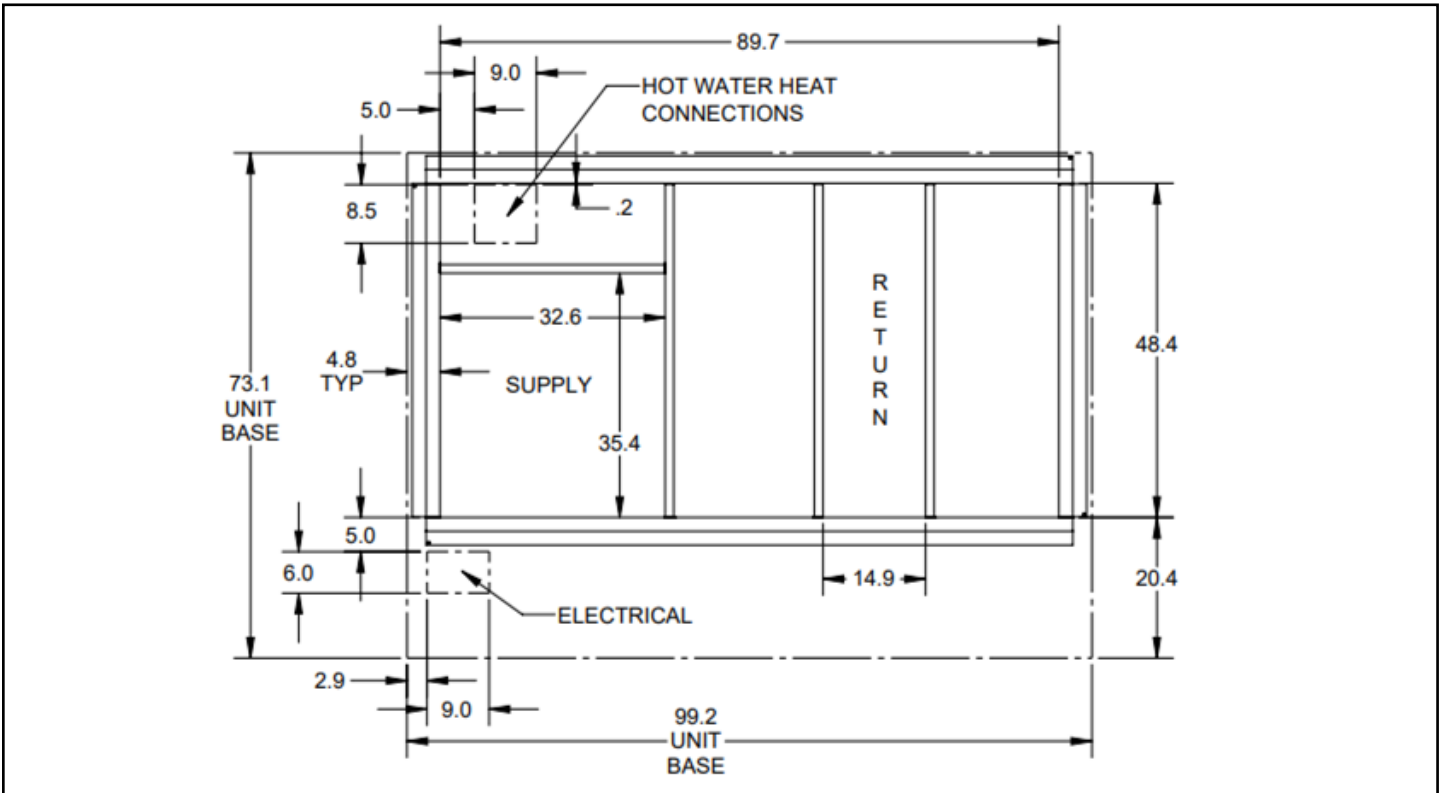

Figure 20: Roof Curb Assembly with CORE ERV (DPS 07-17)

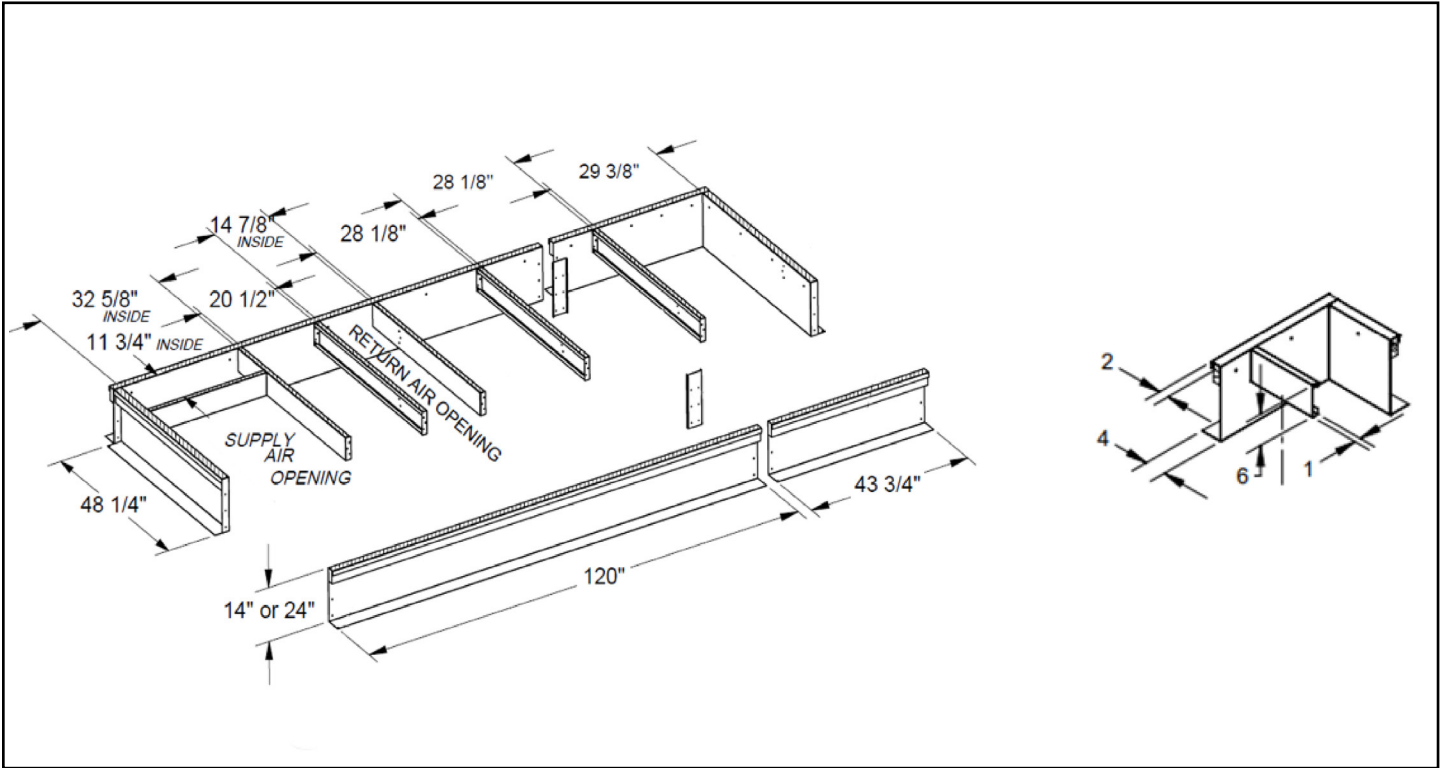

Figure 21: Roof Curb Dimensions with CORE ERV (DPS 07-17)

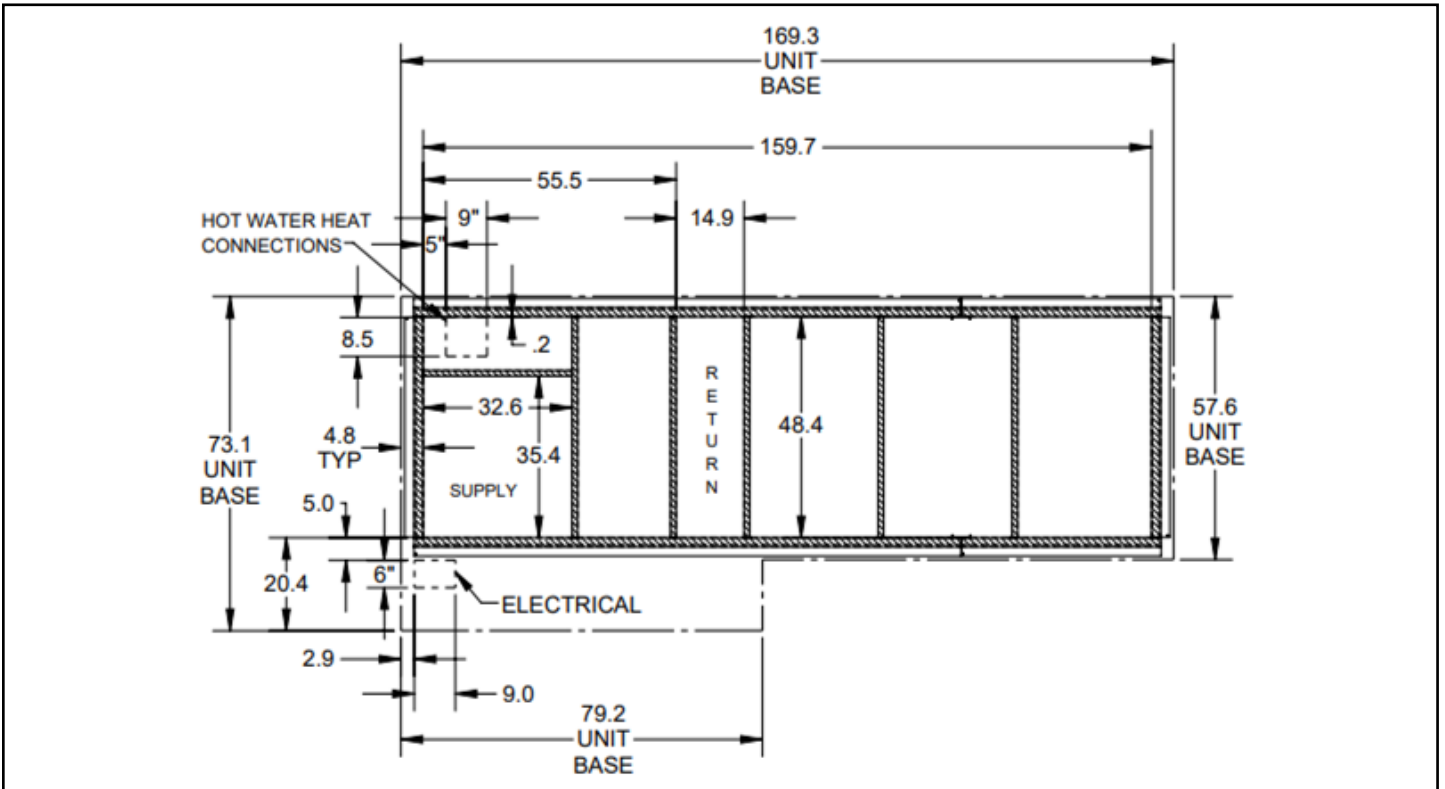

Figure 22: Retrofit Standard Roof Curb Dimensions (DPS 07-17)

NOTE:

Unit will overhang the curb by 20.32 inches (dashed lines).
 Power/Utility opening located outside of roof curb along
 overhang. Approximate location indicated by arrow.

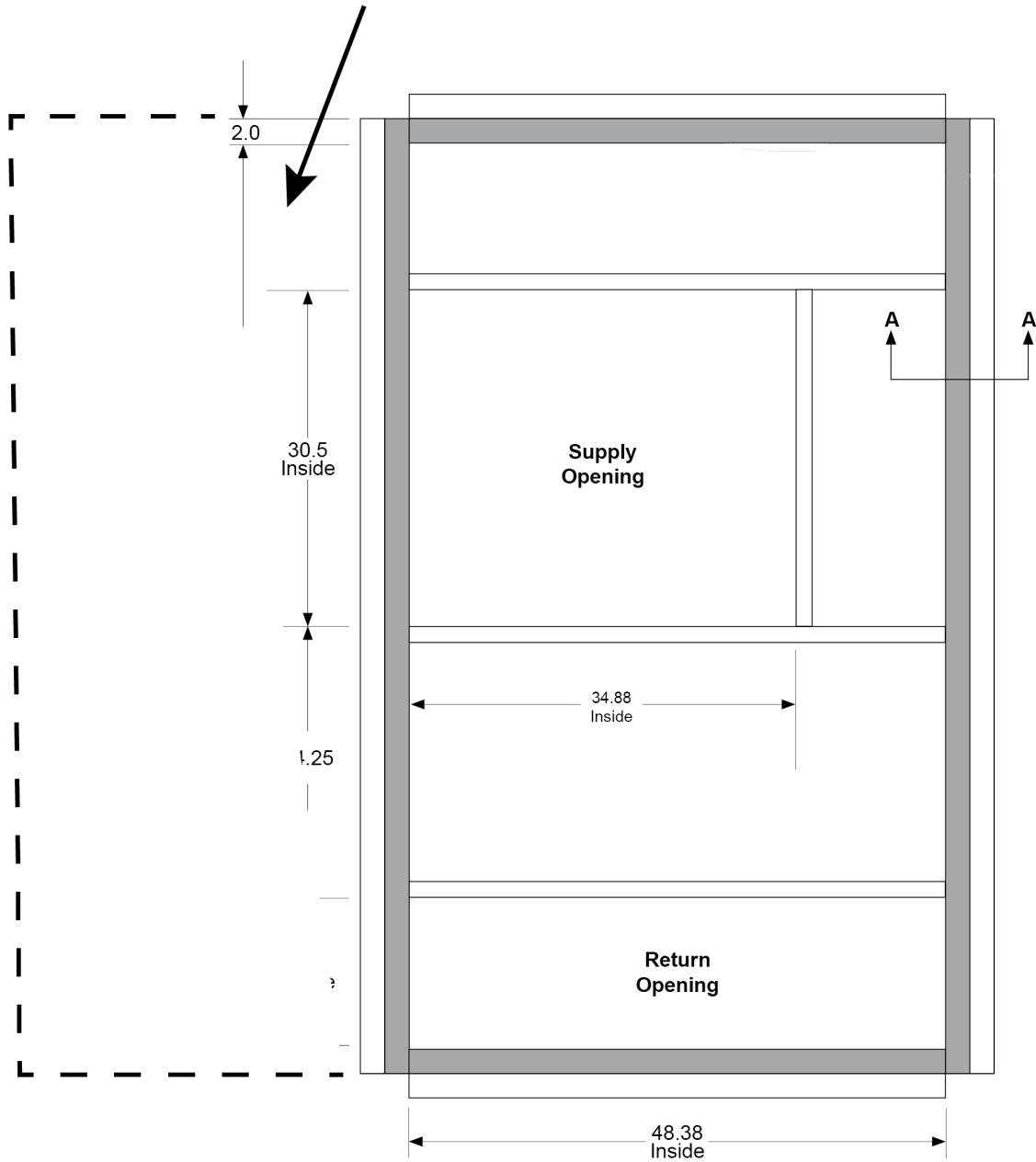

Figure 23: Retrofit Roof Curb Dimensions with ERW (DPS 07-17)

NOTE:

Unit will overhang the curb by 20.32 inches (dashed lines).
Power/Utility opening located outside of roof curb along
overhang. Approximate location indicated by arrow.

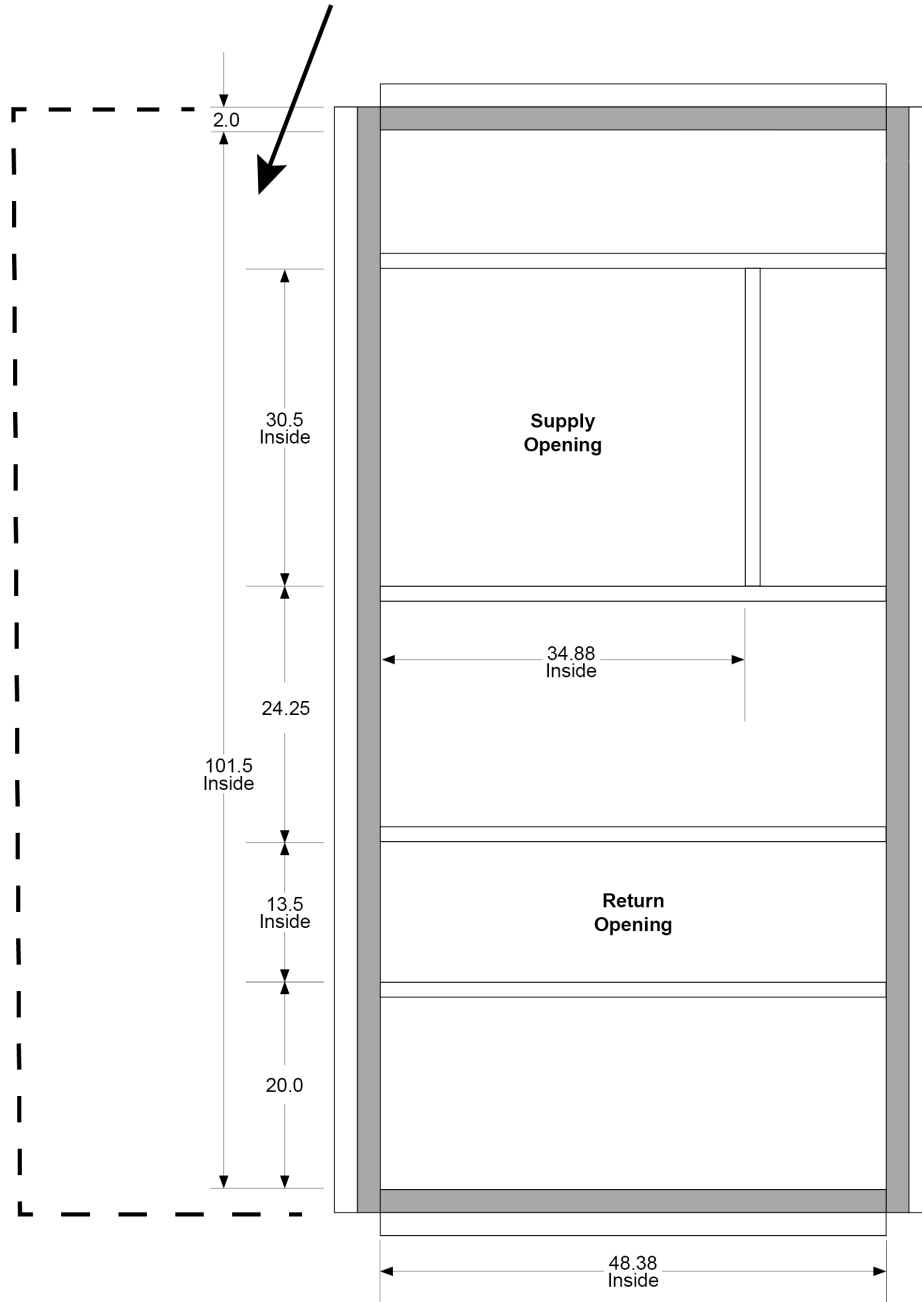

Figure 24: Standard Roof Curb Assembly (DPS 16-31)

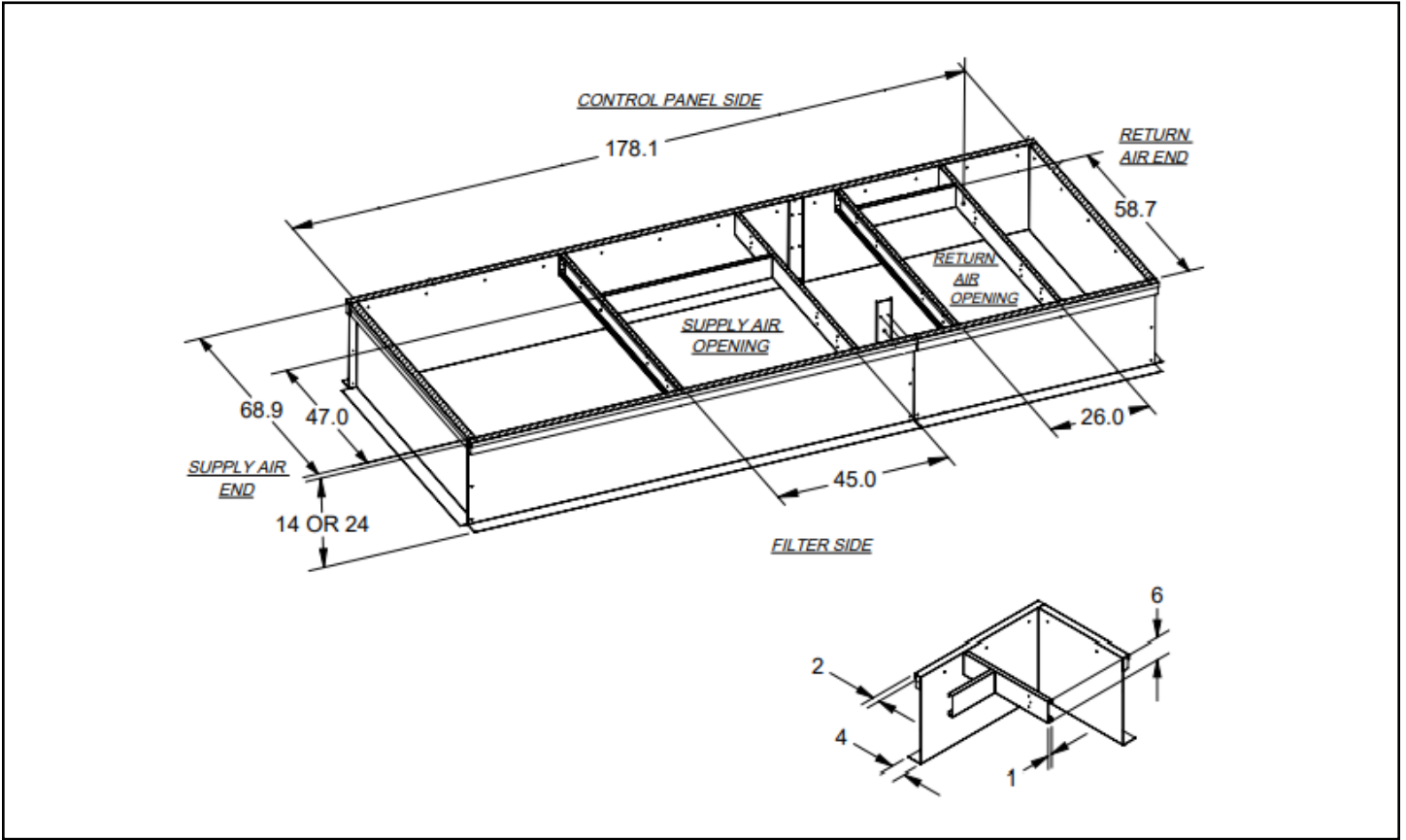

Figure 25: Roof Curb Assembly with ERW (DPS 16-31)

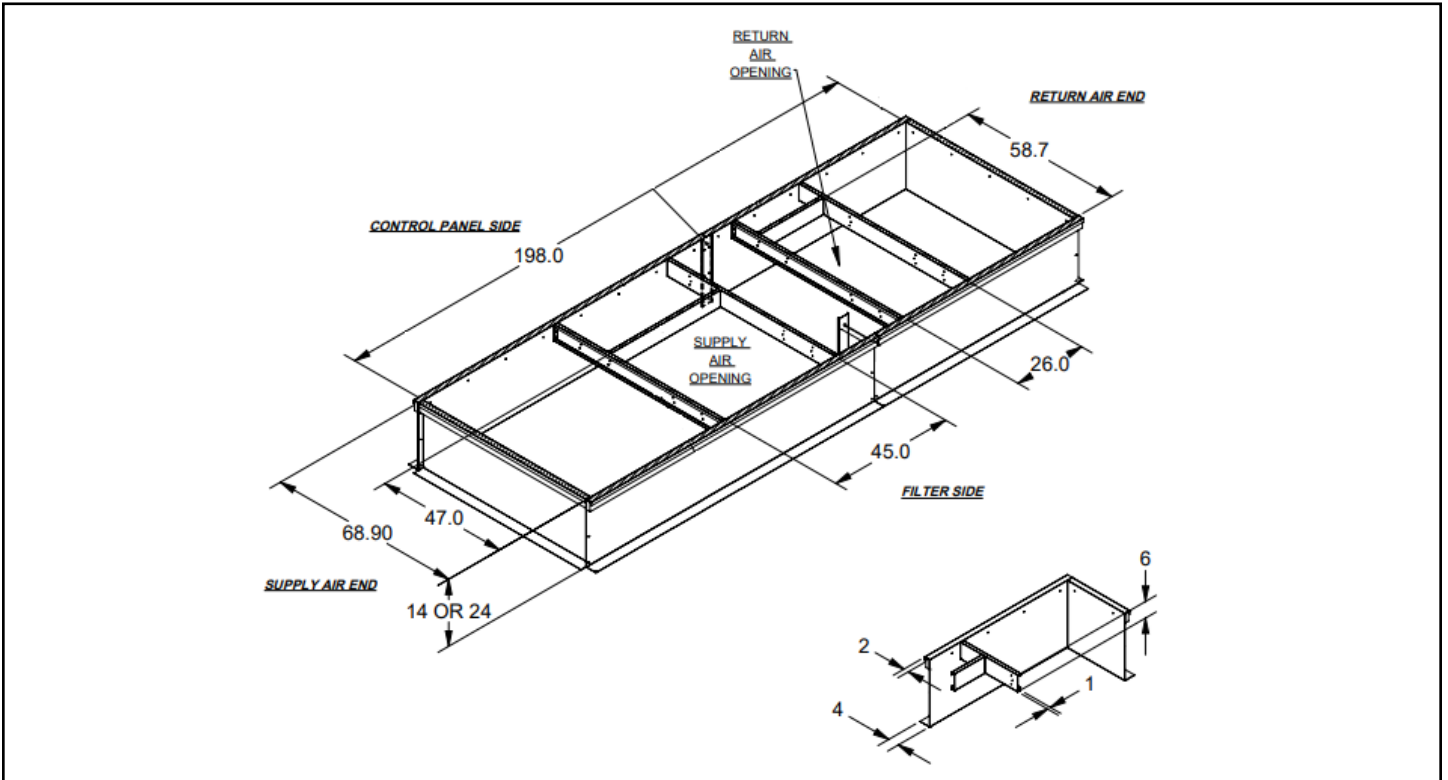

Figure 26: Roof Curb Dimensions with ERW (DPS 16-31)

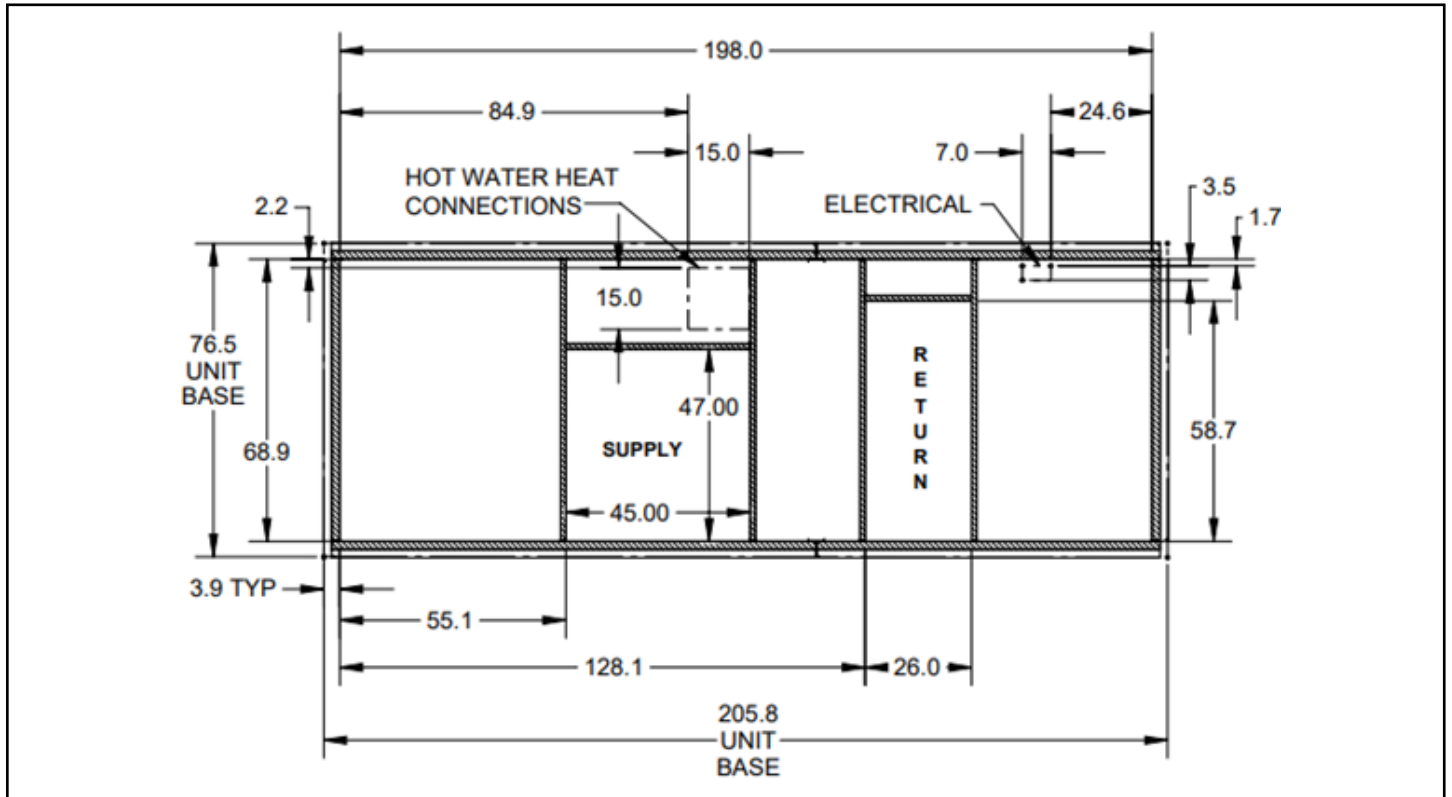
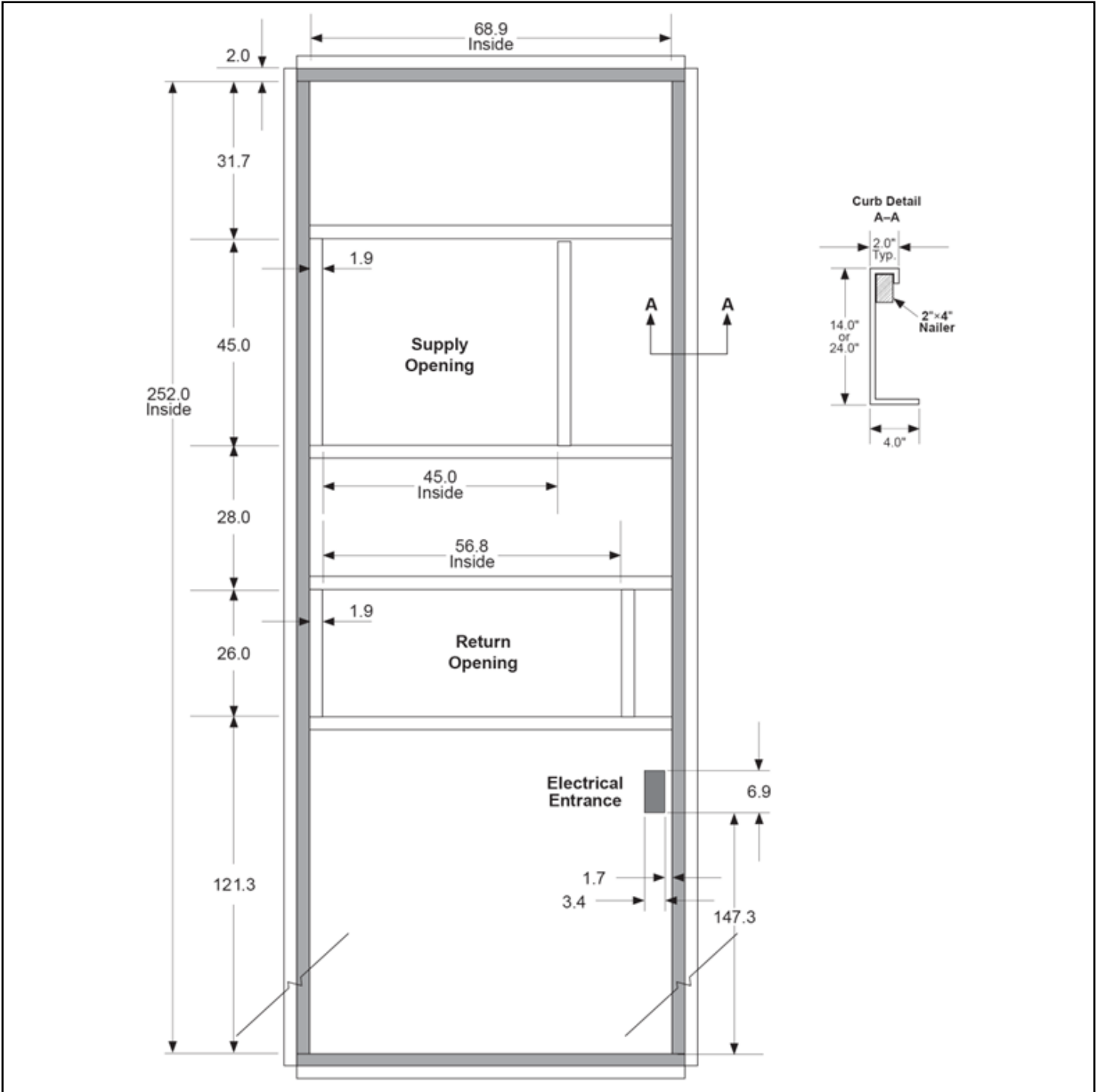

Figure 27: Roof Curb Dimensions with CORE ERV (DPS 16-31)



Lifting Guidance

Daikin Applied equipment is designed to withstand the loads of the lifting and rigging process resulting from ASME Standard P30.1 - Planning for Load Handling Activities or equivalent. Lifting guidance is intended for installations of newly delivered equipment. If moving previously installed equipment for re-location or disposal, consideration should be given to unit condition. Equipment should also be drained as unit weight and center of gravity values do not reflect the addition of water for lifting.

⚠ DANGER

Improper rigging, lifting, or moving of a unit can result in unit damage, property damage, severe personal injury, or death. See the as-designed, certified dimensioned drawings included in the job submittal for the weights and center of gravity of the unit. If the drawings are not available, consult the local Daikin Applied sales office for assistance.

Installation is to be performed only by qualified personnel who are familiar with local codes and regulations, and experienced with this type of equipment. Lifting equipment and mechanisms must be determined by the Lifting Director per the current version of ASME Standard P30.1 or equivalent and must be suited for the load capacity. Daikin Applied is not a licensed nor certified rigging specialist. Therefore it is the customer's responsibility to consult a certified rigging contractor to rig, lift, and move components and subcomponents properly and safely as needed.

⚠ CAUTION

When around sharp edges, wear appropriate Personal Protective Equipment (PPE), such as gloves, protective clothing, foot wear, eye protection, etc. to prevent personal injury.

Forklift Channels

⚠ WARNING

Forklifts may not be used to lift or move units that are not equipped with forklift channels, as this may result in unit damage, property damage, severe personal injury, or death.

Only Rebel cabinets A (03-06) and cabinets B (07-17) without fixed plate CORE energy recovery may be moved or lifted with a forklift. All other units must use overhead rigging for lifting as described in this section.

⚠ CAUTION

Do not lift or move units with a forklift unless the forks are long enough to meet or exceed the length of the forklift channel. Do not set unit on curb without first removing the forklift channels, as unit damage may occur.

Figure 28: Forklift Channels

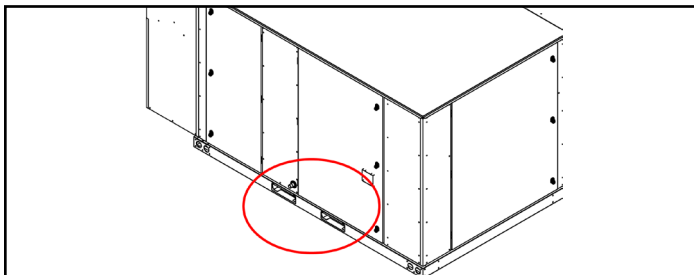

Lifting Brackets

Lifting bracket designs vary from product to product. Rules of engagement with the lifting brackets are the same regardless of the bracket type. For Rebel units, a typical lifting bracket with 2" (51 mm) diameter holes found on the sides of the unit base are illustrated in Figure 29. See the as-designed certified drawings for specific lifting points on this product model.

Engagement with each bracket is to be as close to vertical as possible. The maximum allowable lift angle from the vertical is 30 degrees as shown in Figure 30. If the lift angle shifts beyond 30 degrees from vertical on any of the lift points, the lift shall not proceed until a plan and rigging can be secured that will correct the angle of lift.

⚠ WARNING

The lifting angle must not go beyond 30 degrees from vertical or the unit can become unstable which may result in unit damage, property damage, severe personal injury, or death.

Figure 29: Illustration of Lifting Bracket and Allowed Angle for Lifting

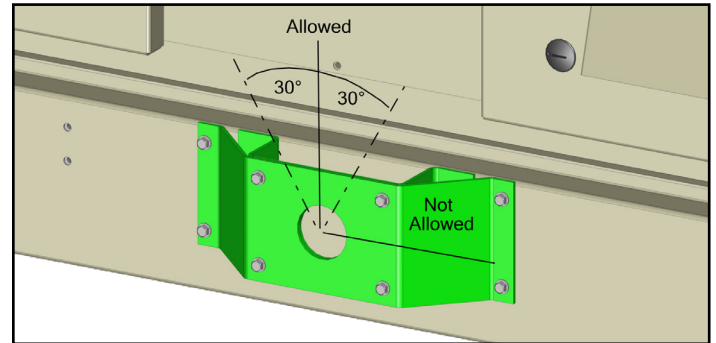

Figure 30: Illustration of Allowed Angle Label

⚠ WARNING

All factory provided lifting points must be used. Unit must remain level during lift and transit!

The lifting and tie-down angle must not go beyond 30 degrees from vertical or the unit can become unstable which may result in unit damage, property damage or severe personal injury or death.

Lifting Equipment

Lifting equipment is supplied by the user or their designate. This is typically selected around the unit certified information of the equipment to be lifted and the available lifting equipment planned to be at the site where the lift is to take place. It is the responsibility of the Lifting Director to follow a standard practice of lift planning and equipment selection, like that found in the ASME P30 series of standards. Lifting plan and equipment must ensure that the only contact with the unit is at that lifting brackets. Straps, chains or spreader bars that are likely to be used shall not come in contact with the unit.

CAUTION

Lifting mechanisms must not make contact with the unit beyond the lifting bracket. Extreme care must be used when rigging the unit to prevent damage to the control panels, unit handles, unit piping, and unit frame.

Lifting Points

Lifting points are predetermined by design. When lifting, all factory installed lifting brackets must be used. Figure 31 illustrates typical 4 point and 6 point lifting configurations. Unit must remain level throughout the entire lifting event. Level is defined as one end being no more than 0.25" per foot of unit length to the opposite end.

WARNING

Be aware that the center of gravity may not necessarily be in the geometric center of the unit. No additional items can be added to a lift with the unit as it may affect the center of gravity and cause unit damage, property damage, severe personal injury, or death. Refer to as-designed, certified drawings for weight, center of gravity location and details specific to unit configuration.

Figure 31: Typical Lifting Point Locations (4 Points)

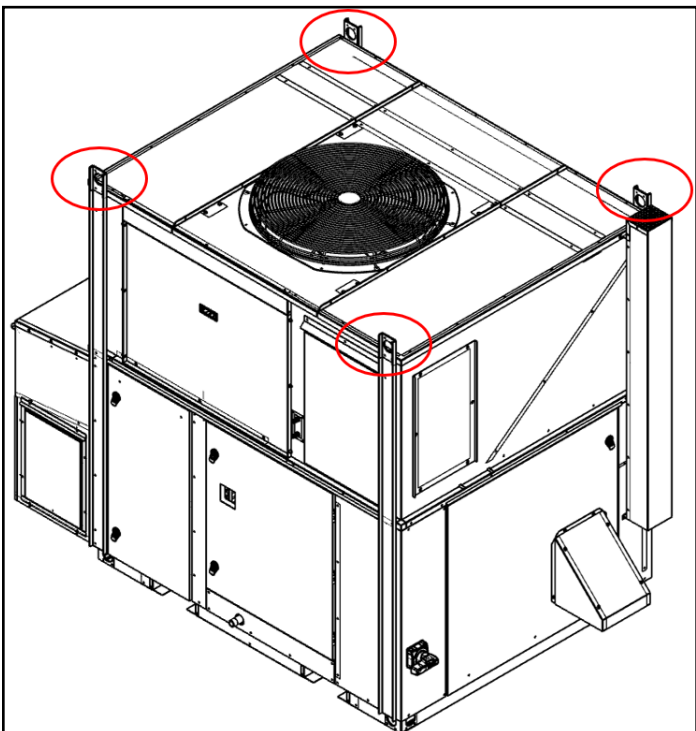

Figure 32: Typical Lifting Point Locations (4 Points)

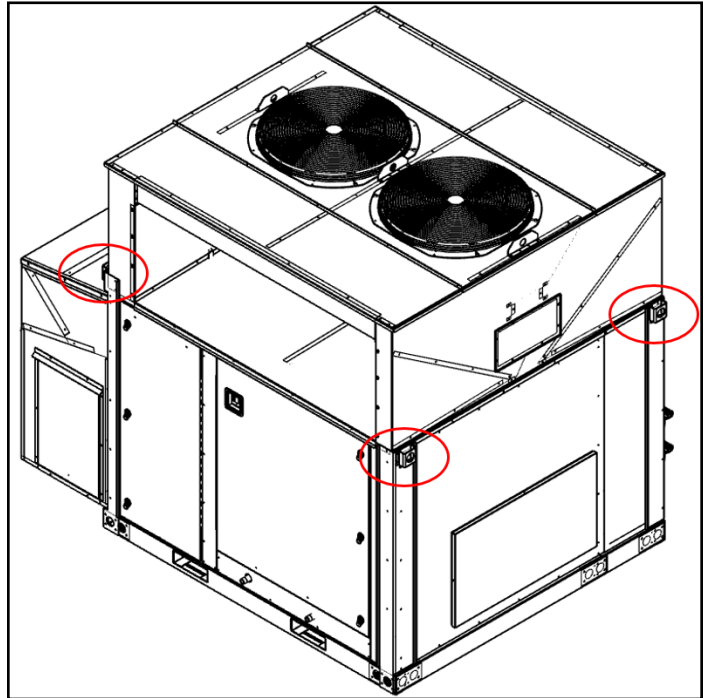
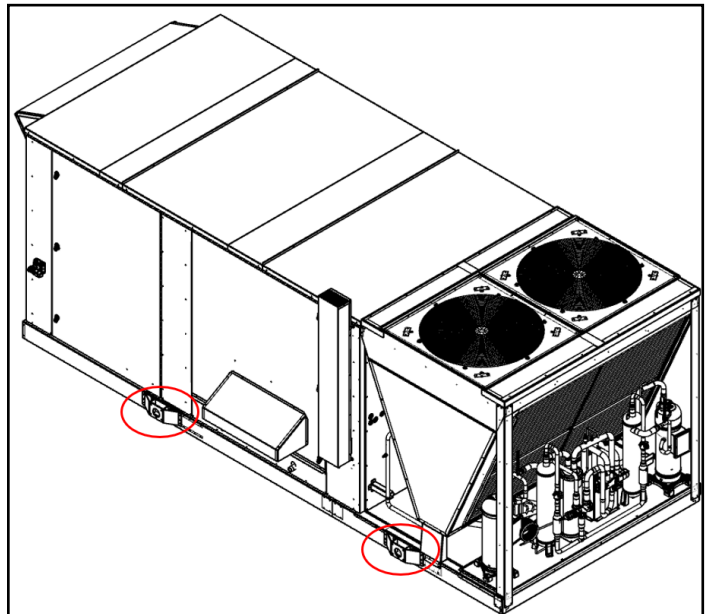

Figure 33: Typical Lifting Point Locations (4 Points)



Transit and Temporary Storage

If the unit is stored for an intermediate period before installation or moved to a different location, take these additional precautions:

1. Support the unit well along the length of the base rail.
2. Level the unit (no twists or uneven ground surface).
3. Provide proper drainage around the unit to prevent flooding of the equipment.
4. Provide adequate protection from vandalism, mechanical contact, etc.
5. Securely close the doors and lock the handles.
6. If there are isolation dampers, make sure they are properly installed and fully closed to prevent the entry of animals and debris through the supply and return air openings.
7. Cover the supply and return air openings on units without isolation dampers.
8. Long term storage in humid environments may cause condensate corrosion on steel surfaces. Consider adding a desiccant material to alleviate corrosion concerns.

When the unit is being tied down for transit, the maximum allowable attachment angle from the vertical is 30 degrees in the opposite direction of lifting in [Figure 30](#). Shimming of the unit under the lifting brackets or tie-down points must be used to ensure even contact along the length of the base rail.

Unit Piping - Condensate Drain Connection

⚠ WARNING

Warning indicates potentially hazardous situations for PVC (Polyvinyl Chloride) and CPVC (Chlorinated Polyvinyl Chloride) piping in chilled water systems. In the event the pipe is exposed to POE (Polyolester) oil used in the refrigerant system, the pipe can be chemically damaged and pipe failure can occur.

⚠ WARNING

Drain pans must be cleaned periodically. Material in uncleaned drain pans can cause disease. Cleaning should be performed by qualified personnel.

The unit is provided with a condensate drain connection, a 3/4" male NPT for 03-17 units and a 1" male NPT for 17-31 units. For proper drainage, level the unit and drain pan side to side and install a P-trap.

[Figure 34](#) shows the layout of the condensate drain connection. The distance from the drain pan outlet to the horizontal run of the P-trap should be a distance of twice the static pressure in the drain pan.

Example: If the static pressure as measured in the drain pan is 1.5", then the distance between the drain outlet and the horizontal run should be 3".

Draining condensate directly onto the roof may be acceptable; refer to local codes. Provide a small drip pad of stone, mortar, wood, or metal to protect the roof against possible damage.

If condensate is piped into the building drainage system, pitch the drain line away from the unit a minimum of 1/8" per foot. The drain line must penetrate the roof external to the unit. Refer to local codes for additional requirements. Sealed drain lines require venting to provide proper condensate flow.

Periodically clean to prevent microbial growth/algae buildup from plugging the drain and causing the drain pan to overflow. Clean drain pans to prevent the spread of disease. Cleaning should be performed by qualified personnel.

Figure 34: Condensate Drain Connection

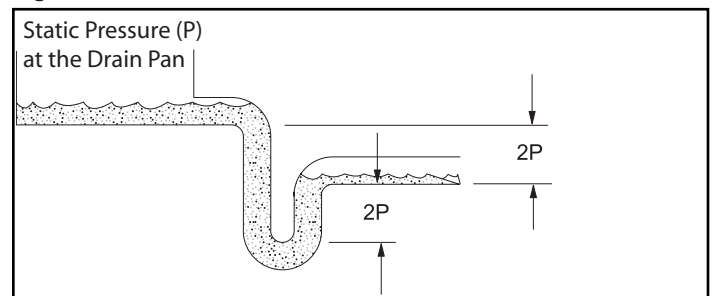

Damper Assemblies

The optional damper assemblies described in this section are ordered with factory-installed actuators and linkages. The following sections describe the operation and linkage adjustment of the factory option.

Figure 35: Damper Assembly

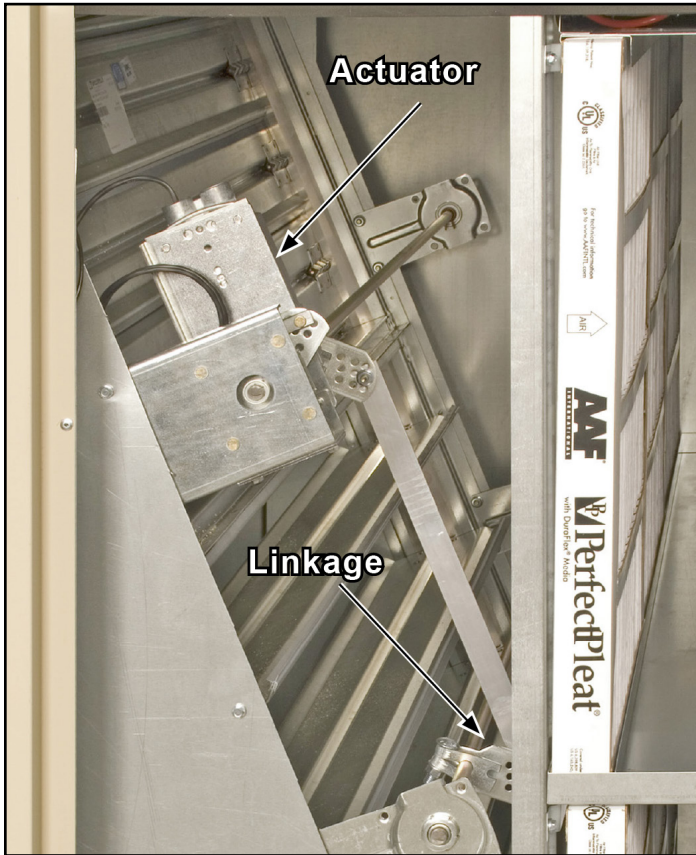

Economizer Dampers

As the single actuator modulates, the outside air dampers open, the return air dampers close, and the exhaust air exits the unit through the gravity relief dampers.

The economizer comes with manually adjustable linkage (Figure 35). The damper is set so that the crank-arm moves through a 90-degree angle to bring the economizer dampers from full open to full close. Mechanical stops are placed in the crank-arm mounting bracket. Do not remove stops. Driving the crank-arm past the stops results in damage to the linkage or damper.

Outdoor Air Dampers (0% to 30%)

These dampers are intended to remain at a fixed position during unit operation, providing fresh air quantities from 0 to 30% of the total system airflow, depending on the damper setting.

The damper position may be set at the unit controller keypad. During unit operation, the damper is driven to the position set at the unit controller. During the OFF cycle, the damper is automatically closed.

Cabinet Weather Protection

⚠ CAUTION

Transportation, rigging, or maintenance can damage the unit's weather seal. Periodically inspect the unit for leakage. Standing moisture can promote microbial growth, disease, or damage to the equipment and building.

This unit ships from the factory with fully gasketed access doors and cabinet caulking to provide weather resistant operation. After the unit is set in place, inspect all door gaskets for shipping damage and replace if necessary.

Protect the unit from overhead runoff from overhangs or other such structures.

Installing Ductwork

WARNING

Mold can cause personal injury. Materials such as gypsum wall board can promote mold growth when damp. Such materials must be protected from moisture that can enter units during maintenance or normal operation.

On vertical-supply/vertical-return units, if a Daikin Applied roof curb is not used, the installing contractor should make an airtight connection by attaching field fabricated duct collars to the bottom surface of the unit's duct opening. Do not support the total weight of the duct work from the unit.

Use flexible connections between the unit and ductwork to avoid transmission of vibration from the unit to the structure.

To minimize losses and sound transmission, design duct work per ASHRAE and SMACNA recommendations.

Where return air ducts are not required, connect a sound absorbing T or L section to the unit return to reduce noise transmission to the occupied space.

Ductwork exposed to outdoor conditions must be built in accordance with ASHRAE and SMACNA recommendations and local building codes.

Auxiliary devices which may be a POTENTIAL IGNITION SOURCE shall not be installed in the duct work. Examples of POTENTIAL IGNITION SOURCES are hot surfaces with temperatures exceeding 1292°F (700°C) and electric switching devices.

Table 5: AHRI CFM Ratings

Unit Size	AHRI Rated CFM	Unit Size	AHRI Rated CFM
3	960	16 B	5300
4	1280	16 C	5120
5	1600	18	5760
6	1920	20	6400
7.5	2930	25	8000
10	4000	30	9600
12	4300	31	9920
15	4800		

Large Rebel units, DPS 16–DPS 31, with horizontal gas heat cannot be directly connected to combustible materials.

Installing Duct Static Pressure Sensor Taps

For all VAV units, duct static pressure taps must be field installed and connected to the static pressure sensor 1 (DSP1) in the unit. Sensor DSP1 is standard on VAV units and is located in the main control panel.

Carefully locate and install the duct static pressure sensing tap. Improperly locating or installing the sensing tap causes unsatisfactory operation of the entire variable air volume system. Below are pressure tap location and installation recommendations. The installation must comply with local code requirements.

1. Install a tee fitting with a leak-tight removable cap in each tube near the sensor fitting. This facilitates connecting a manometer or pressure gauge if testing is required.
2. Use different colored tubing for the duct pressure (HI) and reference pressure (LO) taps, or tag the tubes. Daikin Applied recommends 3/16" ID tubing.
3. Locate the duct pressure (HI) tap approximately 2/3 down the longest run with adequate separation from turns or transitions to assure terminal box take-offs have adequate static pressure.
4. Locate the duct tap in a nonturbulent flow area of the duct. Keep it several duct diameters away from take-off points, bends, neckdowns, attenuators, vanes, or other irregularities.
5. Use a static pressure tip (Dwyer A302 or equivalent) or the bare end of the plastic tubing for the duct tap. (If the duct is lined inside, use a static pressure tip device.)
6. Install the duct tap so that it senses only static pressure (not velocity pressure). If a bare tube end is used, it must be smooth, square (not cut at an angle) and perpendicular to the airstream (see [Figure 37](#)).
7. Locate the reference pressure (LO) tap near the duct pressure tap within the building. If the tap is not connected to the sensor, unsatisfactory operation will result.
8. Route the tubes through the curb and feed them into the unit through the knockout in the bottom of the control panel (see [Figure 36](#)). Connect the tubes to appropriate barbed fittings (on SPS1) in the control panel. (Fittings are sized to accept 3/16" ID tubing).

Figure 36: Typical Wiring Chase, Size 03–06 Shown

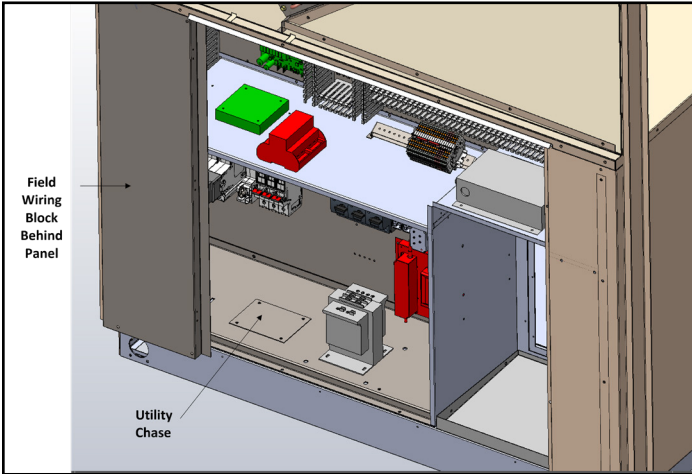
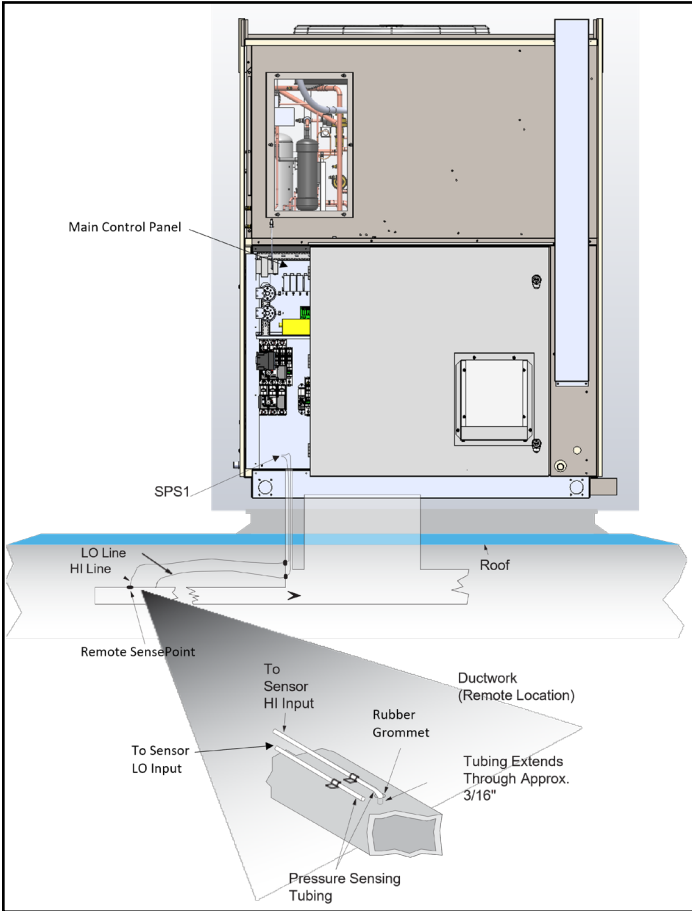

Figure 37: Duct Static Pressure Sensing Tubing Installation



Installing Building Static Pressure Sensor Taps

CAUTION

Fragile sensor fittings. If you must remove tubing from a pressure sensor fitting, use care. Do not use excessive force or wrench the tubing back and forth to remove or the fitting can break off and damage sensor.

If a unit has building static pressure control capability, you must field install and connect static pressure taps to the static pressure sensor SPS2 in the unit. This sensor is located at the bottom of the main control panel next to SPS1.

Carefully locate and install the two static pressure sensing taps. Improper location or installation of the sensor taps causes unsatisfactory operation. Below are pressure tap location and installation recommendations for both building envelope and lab, or “space within a space” pressure control applications. The installation must comply with local code requirements.

Building Pressurization Applications

1. Install a tee fitting with a leak-tight removable cap in each tube near the sensor fitting. This facilitates connecting a manometer or pressure gauge if testing is required.
2. Locate the building pressure (high) tap in the area that requires the closest control. Typically, this is a ground level floor that has doors to the outside.
3. Locate the building tap so it is not influenced by any source of moving air (velocity pressure). These sources may include air diffusers or outside doors.
4. Route the building tap tube through the curb and feed it into the unit through the knockout in the bottom of the control panel (refer to Figure 36). Connect the 3/16" ID tube to the (high) fitting for sensor SPS2.
5. Locate the reference pressure (low) tap on the roof. Keep it away from the condenser fans, walls, or anything else that may cause air turbulence. Mount it high enough above the roof so it is not affected by snow. Not connecting the reference tap to the sensor results in unsatisfactory operation.
6. Use an outdoor static pressure tip (Dwyer A306 or equivalent) to minimize the adverse effects of wind. Place some type of screen over the sensor to keep out insects. Loosely packed cotton works well.
7. Route the outdoor tap tube out of the main control panel through a small field-cut opening in the upright. Seal the penetration to prevent water from entering. Connect the 3/16" ID tube to the (low) fitting for sensor SPS2.

Discharge Air Temperature Sensor

The discharge air temperature sensor must be installed in the discharge air duct, downstream of the rooftop unit. Locate the sensor in a location that closely approximates the average duct temperature. To avoid the effects of radiation, the sensor should not be in the line-of-sight of a gas furnace or electric heater. Generally, locate sensor in the center of a duct wall, 5' – 10' from unit opening to allow for air mixing. Do not mount down stream of VAV boxes or other dampers.

Installation: Drill 7/8" diameter hole in duct, insert sensor probe and secure plate to duct with 2 – #10 screws. Be sure to apply gasket or silicone sealant to back of mounting plate prior to screwing plate to the duct to create an air-tight seal.

NOTE: If there is a stratification concern up to 4 sensors can be utilized with an averaging signal. Sensors must be wired in parallel.

Discharge Air Temperature Sensor Installation

Figure 38: Discharge Air Temperature Sensor Diagram

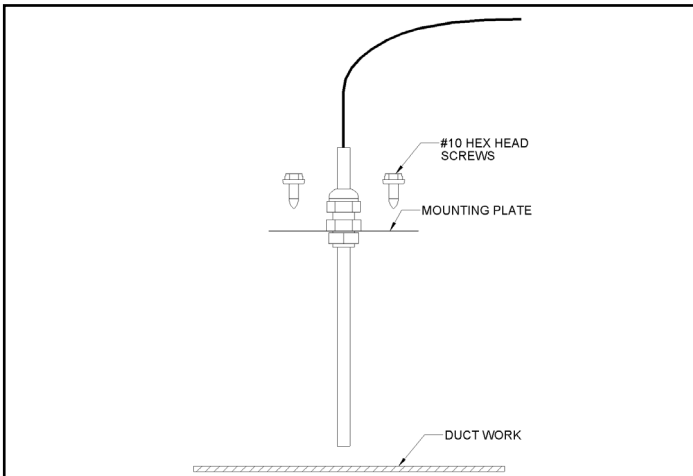

Optional Ultraviolet (UV) Lights

WARNING

POSSIBLE EXPOSURE TO ULTRAVIOLET RADIATION AND HAZARDOUS VOLTAGE!

Failure to disconnect power before servicing could result in severe electrocution or burns leading to serious injury or death. This product contains components that emit Ultraviolet Light radiation (UV-C) which can be harmful to the skin and unprotected eyes. Disconnect all electrical power, including remote disconnects, and ensure UV lights are off before servicing. Follow proper LOCKOUT/TAGOUT procedures to ensure the power cannot be energized while in service.

CAUTION

Unintended use of the appliance or damage to the housing may result in the escape of dangerous UV-C radiation. UV-C radiation may, even in small doses, cause harm to the eyes and skin, leading to personal injury.

UV appliances that show signs of damage should not be operated.

Do not operate UV-C lamps outside of the unit.

Do not operate or service the UV-C Lamp System before fully reading these instructions.

All appliances equipped with a UV-C Lamp System will be shipped with all sheet metal and wiring in place. The UV-C lamps will need to be installed in the field. The lamp will be packaged inside the unit for protection during transit.

Doors and access panels bearing the ultraviolet radiation hazard symbol (as seen on [page 5](#)) which may have UV-C spectral irradiance greater than 1.7 $\mu\text{W}/\text{cm}^2$ are provided with an interlock switch to interrupt the power to the UV-C lamps for your safety. Do not over-ride.

NOTICE

UV-C barriers bearing the ultraviolet radiation hazard symbol should not be removed.

Installing Ultraviolet (UV) Lamps

Always wear protective eyewear and gloves before handling the UV-C Lamp System. Perform the following steps to install UV-C lamps:

1. Disconnect power to the unit.
2. Clean the UV-C lamp with alcohol and a lint-free soft cloth.

NOTE: Avoid touching the UV-C lamp without gloves on as fingerprints can degrade the lamp's performance.

3. Push the UV-C lamp into the spring clips.
4. Connect the UV-C lamp wiring harness to the end of the UV-C lamp.
5. Connect power to the unit and observe through the viewport that the UV-C lamp is on.

Figure 39: UV-C Lamp Spring Clip Example

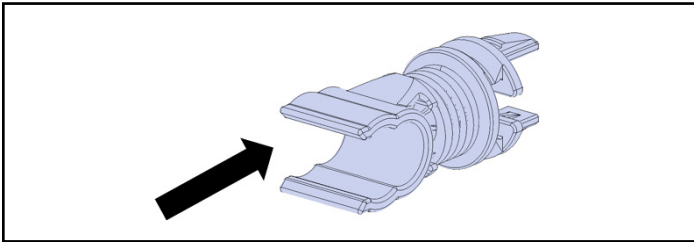

Cleaning Ultraviolet (UV) Lamps

Clean of the UV-C lamps every 3 months using a lint-free soft cloth. Always wear protective eyewear and gloves before handling the UV-C Lamp System. Perform the following steps to clean the UV-C lamps:

1. Disconnect power to the unit.
2. Allow the lamp to cool for 5 minutes.
3. Disconnect the UV-C lamp wiring harness located at the end of the UV-C lamp.
4. Grasp the body of the lamp and pull away from the spring clip holding the lamp in place to remove from the unit.
5. Clean the UV-C lamp with alcohol and a lint-free soft cloth.

NOTE: Avoid touching the UV-C lamp without gloves on as fingerprints can degrade the lamp's performance.

6. Reverse steps 1 through 5 to reinstall the clean UV-C lamp.
7. Connect power to the appliance and observe through the viewport that the UV-C lamp is on.

Replacing Ultraviolet (UV) Lamps

Replace the UV-C lamps every 9,000 hours or annually, even if the bulbs still emit light. Perform the following steps to replace the UV-C lamps:

1. Disconnect power to the unit.
2. Allow the lamp to cool for 5 minutes.
3. Disconnect the UV-C lamp wiring harness located at the end of the UV-C lamp.
4. Grasp the body of the lamp and pull away from the spring clip holding the lamp in place to remove from the unit.

Replace UV-C lamps and UV-C Lamp Systems with their corresponding unit cabinet size as specified in Table 6. Contact the Daikin Applied Parts group if a UV-C lamp or the UV-C Lamp System requires replacing. Install new lamps by following the steps outlined in the "Installing Ultraviolet (UV) Lamps" section.

Table 6: UV-C Lamp Replacement Information

Cabinet	A	B	C
Manufacturer	Ultraviolet Devices Inc.		
UV-C Lamp System Model	40-6211-XX	40-6481-XX	40-6611-XX
Technical Data	UV Lamp, 21", 50W	UV Lamp, 48", 100W	UV Lamp, 61", 140W
	0.75A @120V	1.24A @120V	1.30A @120V
	0.40A @240V	0.65A @240V	0.65A @240V

Electrical Installation

DANGER

Hazardous voltage. Can cause severe personal injury or death.

Disconnect electric power before servicing equipment. More than one disconnect may be required to de-energize the unit.

DANGER

Overheating or failure of the gas supply to shut off can cause equipment damage, severe personal injury, or death.

Turn off the manual gas valve to the appliance before shutting off the electrical supply.

WARNING

Provide proper line voltage and phase balance.

Improper line voltage or excessive phase imbalance constitutes product abuse. It can cause severe damage to the unit's electrical components.

WARNING

Electrical shock hazard. Can cause severe personal injury or death.

Connect only low voltage NEC Class II circuits to terminal block TB2.

CAUTION

All penetrations made through control panel knockouts must be sealed to prevent leaks. Gaps around field conductors and wiring should be sealed using elastic compound. Failure to do so may result in property damage.

Electrostatic Discharge (ESD)

Disconnect Power to the Rebel Rooftop Unit prior to inspecting and/or repairing.

When inspecting/repairing Rebel Rooftop units the technician or building owner must take precautions to ground themselves to the unit. This will prevent them from damaging the circuit boards mounted inside the inverter box, VFD, and main control panel.

Electrostatic Discharge (ESD) can damage components in a manner that is not always readily detectable. A static potential can easily be generated on a person that reaches 25 kVolts. If this potential is discharged into one of the unit's circuit boards it can degrade part of the current carrying conductors inside.

In order to prevent ESD damage the technician and the unit must both be at the same electrical potential. The technician must ground themselves to the unit; this can be achieved by touching any galvanized (not painted) section of the unit. The unit's base rail and refrigerant piping are both reliable options as well as the control panel backpanel. The next step is to attach a grounded wrist or ankle strap to the copper tubing or backpanel. This grounding strap must have direct contact with the technician's skin. Once this has been done the technician is free to work on electrical components inside the unit.

All Units

Wiring must comply with all applicable codes and ordinances. The warranty is voided if wiring is not in accordance with these specifications.

According to the National Electrical Code (NEC), a disconnecting means shall be located within sight of and readily accessible from the air conditioning equipment. The unit can be ordered with an optional factory mounted disconnect switch. This switch is not fused unless ordered with a fuse. Power leads must be over-current protected at the point of distribution. The maximum rated overcurrent protection device (MROPD) value appears on the unit nameplate.

All units are provided with internal power wiring for single point power connection. The power block or an optional disconnect switch is located within the main control panel. Field power leads are brought into the unit through knockouts in the bottom of the main control panel (see [Figure 36](#) and also [Table 7](#)). Refer to the unit nameplate to determine the number of power connections.

NOTE: Two wire entry points, refer to certified drawings for dimensions.

WARNING

Provide proper line voltage and phase balance.

Improper line voltage or excessive phase imbalance constitutes product abuse. Severe electrical component damage will occur.

WARNING

Electrical shock hazard. Can cause severe personal injury or death.

Connect only low voltage NEC Class II circuits to terminal block TB2.

Table 7: DPS 03-17, Recommended Field Power Wiring

Ampacity (MCA)	Number of Power Wires Per Phase	Wire Gauge	Insulation Temperature Rating (°C)
20	1	14	75
25	1	12	75
35	1	10	75
50	1	8	75
65	1	6	75
85	1	4	75
100	1	3	75
115	1	2	75
130	1	1	75
150	1	1/0	75
175	1	2/0	75
200	1	3/0	75
230	1	4/0	75
255	1	250	75
285	1	300	75
310	1	350	75
335	1	400	75
380	1	500	75
420	1	600	75

Table 8: DPS 16-31, Recommended Field Power Wiring

MROPD	Wire Qty per Pole	Wire Range of Standard Lug	Anticipated Wire Size
20	1	#18-8	(1) 10
25	1	#18-8	(1) 8
30	1	#18-8	(1) 8
35	1	#14-4	(1) 6
40	1	#14-4	(1) 6
45	1	#14-4	(1) 6
50	1	#14-4	(1) 6
60	1	#14-4	(1) 4
70	1	#14-2/0	(1) 3
80	1	#14-2/0	(1) 3
90	1	#14-2/0	(1) 2
100	1	#14-2/0	(1) 2
110	1	#4-300 mcm	(1) 1
125	1	#4-300 mcm	(1) 1/0
150	1	#4-300 mcm	(1) 2/0
150	1	#4-350 mcm	(1) 2/0
100	1	#14-1/0	(1) 2
175	1	#4-300 mcm	(1) 3/0
200	1	#4-300 mcm	(1) 4/0
175	1	#14-2/0	(1) 3/0
225	1	#2-600 mcm	(1) 250 mcm
225	2	#4-300 mcm	(2) 1
225	1	#4-350 mcm	(1) 250 mcm
250	1	#2-600 mcm	(1) 300 mcm
250	2	#4-300 mcm	(2) 1/0
250	1	#6-350 mcm	(1) 300 mcm
300	1	#2-600 mcm	(1) 400 mcm
300	1	#6-350 mcm	(1) 400 mcm
300	1	#6-350 mcm	(1) 400 mcm
300	1	#6-400 mcm	(1) 400 mcm
300	2	#4-300 mcm	(2) 2/0
350	1	#2-600 mcm	(1) 600 mcm
350	1	#4-500 mcm	(1) 600 mcm
350	2	#4-300 mcm	(2) 3/0
350	2	#6-2/0	(2) 3/0
400	1	#2-600 mcm	(1) 700 mcm
400	1	#2-600 mcm	(1) 700 mcm
400	2	#4-300 mcm	(2) 4/0
300	1	#250-500 mcm	(1) 400 mcm
400	2	#3/0-250 mcm	(2) 4/0
500	2	#1/0-250 mcm	(2) 250 mcm
600	2	#4-350 mcm	(2) 400 mcm
600	2	#3/0-500 mcm	(2) 400 mcm

**WARNING**

Overheating or failure of the gas supply to shut off can cause equipment damage, severe personal injury, or death.
Turn off the manual gas valve to the appliance before shutting off the electrical supply.

The preferred entrance for power cables is through the bottom knockouts provided on the unit. If a side entrance is the only option, a hole may be drilled in the stationary upright.

The minimum circuit ampacity (MCA) is shown on the unit nameplate. Refer to [Table 7](#) for the recommended number of power wires.

Copper wire is required for all conductors. Size wires in accordance with the ampacity tables in Article 310 of the [National Electrical Code](#) or other applicable code. If long wires are required, it may be necessary to increase the wire size to prevent excessive voltage drop. Wires should be sized for a maximum of 3% voltage drop. Supply voltage must not vary by more than 10% of nameplate. Phase voltage imbalance must not exceed 2%. (This can be calculated by finding the average voltage of the three legs. The leg with voltage deviating the farthest from the average value must not be more than 2% away.) Daikin Applied suggests contacting the local power company for correction of improper voltage or phase imbalance.

The power source to the unit must be a balanced 3-phase power supply, meaning that the voltage and impedance to the line is matched. Unbalanced voltage and/or current (such as provided with an "Open Delta" configuration), is likely to result in nuisance alarms, premature failure of components and it will void equipment warranty. **Daikin Applied does not recommend the use of Rebel units in facilities with corner grounded delta power.**

A grounded conductor lug is provided in the control panel. Size the grounding conductor in accordance with the National Electrical Code or other applicable local electrical codes.

In compliance with the National Electrical Code, a 120 V factory mounted service receptacle outlet is provided. This outlet must be powered by a field connected 15 A, 120 V power supply, unless unit power outlet was utilized. Leads are brought into the unit through the bottom of the main control panel.

Field Control Wiring

The Rebel rooftop units are available with the following field control connections:

- Space sensor.
- Space sensor with setpoint adjustment.
- Fan operation output.
- VAV box output.
- Remote alarm output.
- External discharge air temperature reset.
- Outdoor air damper minimum position adjustment.

Descriptions of these field connections are included in the MicroTech Unit Controller Manual.

Start-up and service of this equipment must be performed by trained and experienced technicians. It is highly recommended that the initial start-up and future service be performed by Daikin Applied trained technicians who are familiar with working on live equipment. A representative of the owner or the operator of the equipment should be present during start-up to receive instructions in the operation, care and adjustment of the unit. Daikin Applied recommends proper use of personal protection equipment whenever starting and/or servicing a unit.

Before Start-Up

1. Notify inspectors or representatives who may be required to be present during start-up of gas fuel equipment. These could include the gas utility company, city gas inspectors, heating inspectors, etc.
2. Review the equipment and service literature and become familiar with the location and purpose of the furnace controls. Determine where the gas and power can be turned off at the unit and before the unit.
3. Determine that power is connected to the unit and available.
4. Determine that the gas piping, meter, and service regulator have been installed, tested, and meet the equipment requirements.
5. Determine that proper instruments will be available for the start-up. A proper start-up requires the following: voltmeter, manometer or gauges with ranges for both manifold pressure and inlet gas pressure.

Table 9: DPS 03-06 Electric Heat Data

kW	Voltage	Amps
6	208	16.6
	240	14.4
	480	7.2
	600	5.8
12	208	33.1
	240	28.7
	480	14.4
	600	11.5
18	208	49.6
	240	43.0
	480	21.5
	600	17.2
30	208	82.5
	240	71.5
	480	35.8
	600	28.7

NOTE: 200 FPM minimum airflow across heater.

Table 10: DPS 07-17 Electric Heat Data

kW	Voltage	Amps
18	208	49.6
	240	43.0
	480	21.5
	600	17.2
36	208	99.0
	240	85.8
	480	43.0
	600	34.4
54	208	148.5
	240	128.7
	480	64.4
	600	51.5
72	208	197.9
	240	171.5
	480	85.8
	600	68.7

NOTE: 200 FPM minimum airflow across heater.

Table 11: DPS 016-31 Electric Heat Data

kW	Voltage	Amps
10	208	27.8
	240	24.1
	480	12.0
	600	9.6
20	208	55.5
	240	48.1
	480	24.1
	600	19.2
30	208	83.3
	240	72.2
	480	36.1
	600	28.9
45	208	124.9
	240	108.3
	480	54.1
	600	43.3
60	208	166.5
	240	144.3
	480	72.2
	600	57.7
72	208	199.9
	240	173.2
	480	86.6
	600	69.3
90	208	249.8
	240	216.5
	480	108.3
	600	86.6
120	—	—
	—	—
	480	144.3
	600	115.5
150	—	—
	—	—
	480	180.4
	600	144.3

NOTE: 200 FPM minimum airflow across heater.

Refrigeration System

Piping System

The Rebel piping system varies significantly between the multiple possible configurations; heat pump, cooling only, and modulating hot gas reheat. In spite of this multiplicity there are some consistent characteristics. All units have a single circuit with a single or tandem compressor. All units use an electronic expansion valve.

Figure 40: Typical Refrigeration Circuit for Cooling Only Unit with Modulating Hot Gas Reheat

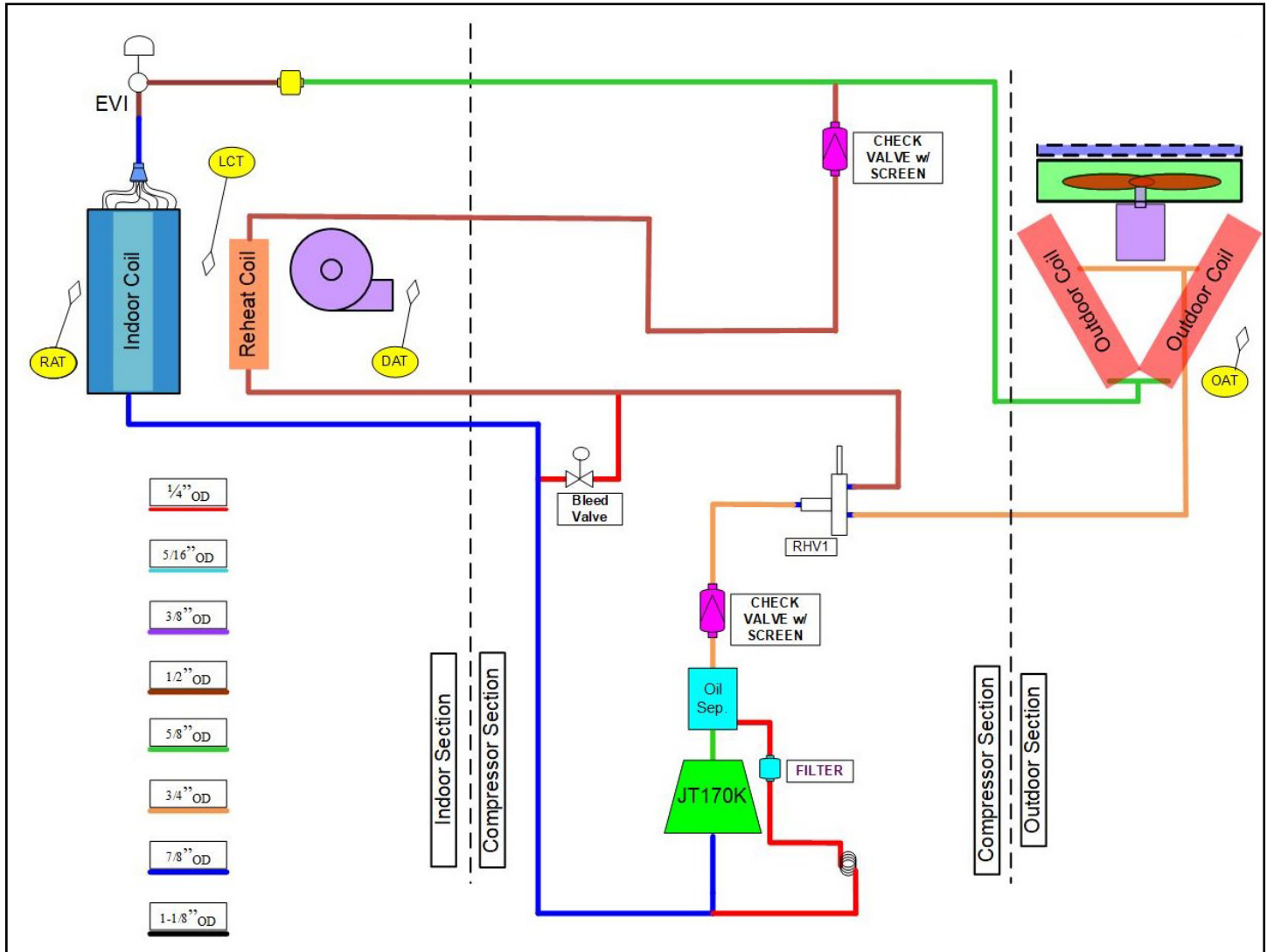

Figure 41: Typical Refrigeration Circuit for Heat Pump Unit with Modulating Hot Gas Reheat

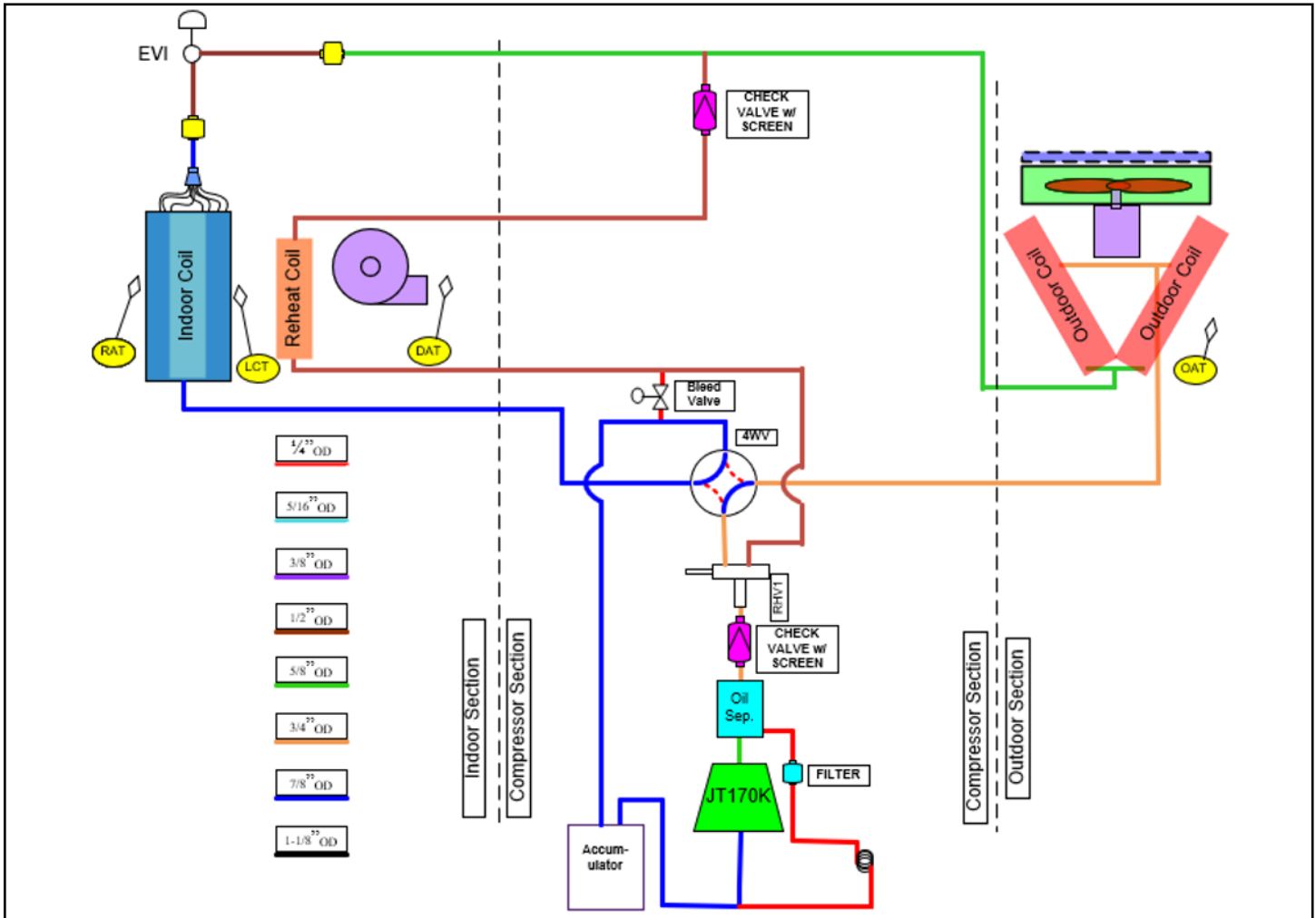

Table 12: Component Descriptions

Item	Description
EVI	Indoor coil electronic expansion valve
EVO	Outdoor coil electronic expansion valve
CV	Check Valve, size 3-15 only
REC	Refrigerant Receiver
IDF	Indoor fan
ODF	Outdoor fan
VCmp1	Inverter compressor
C1FCmp3	Fixed speed compressor (7½ thru 16 ton and 25-31 only)
RHV	Reheat step valve
SVR	Receiver solenoid valve
CHV	Condenser step valve
4WV	4-way heat pump valve
OS	Oil separator

DPS Component Description

Compressor Compartment

Prior to start-up, verify all shipping brackets are removed and the compressor foot bolts are secured.

Figure 42: Compressor Brackets

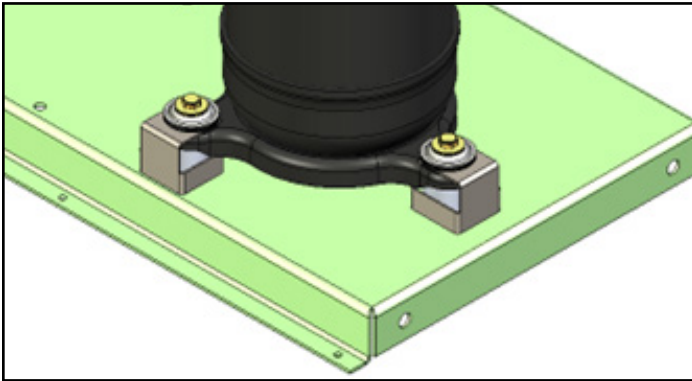

Variable Speed Compressor

A variable speed compressor is used on all DPS units. Depending on the size of the unit, the compressor used can change:

- DPS 03-06 units use swing compressors which have the suction coming out the side and the discharge coming out the top.
- DPS 07-31 units use scroll compressors which have the suction coming out the top and the discharge coming out the side.

These pipes can also be identified by recalling that suction lines will always be larger than discharge lines.

Figure 43: Compressor Suction and Discharge

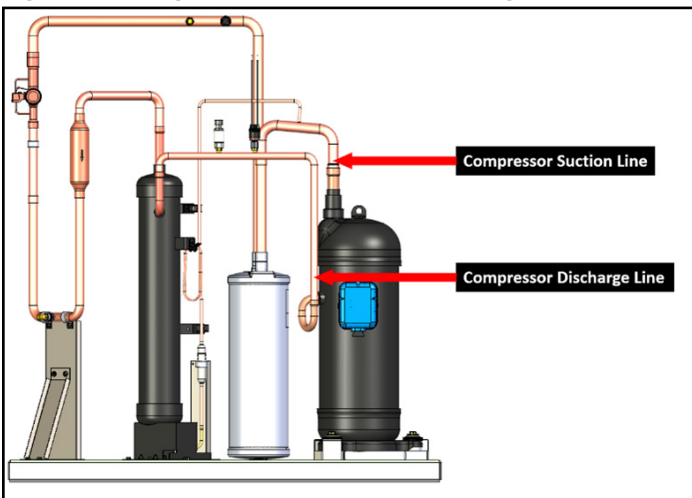

Oil Separator

All DPS units will have an oil separator on the discharge line of the compressor. This device will remove oil from the compressor discharge gas and return it to the compressor suction line. The oil separator has three lines entering it. The connection on the side of the compressor is where the discharge gas enters. The hot gas continues on to the Outdoor Coil from the connection on the top of the separator. On the bottom is a small drain through which the oil returns after separation to the compressor suction. The refrigerant and oil path through the separator will not change depending on Heating or Cooling Mode.

Figure 44: Oil Separator

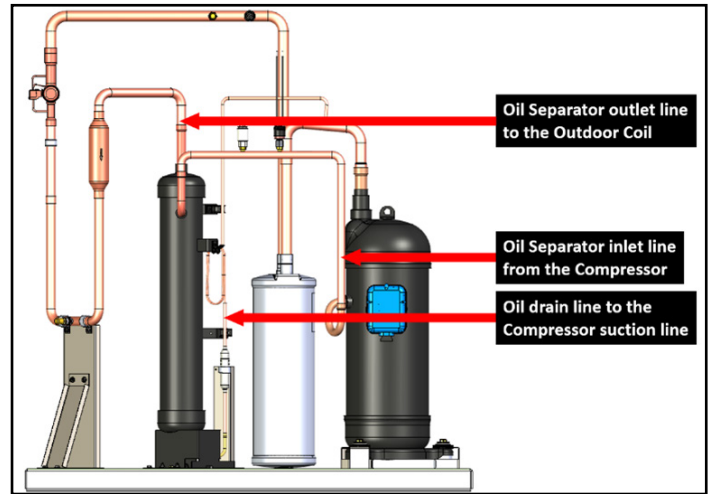

Check Valve

All DPS units will have check valves on each of the compressor discharge lines. The check valve prevents migration of refrigerant into the compressor during off cycles.

Figure 45: Discharge Line Check Valves

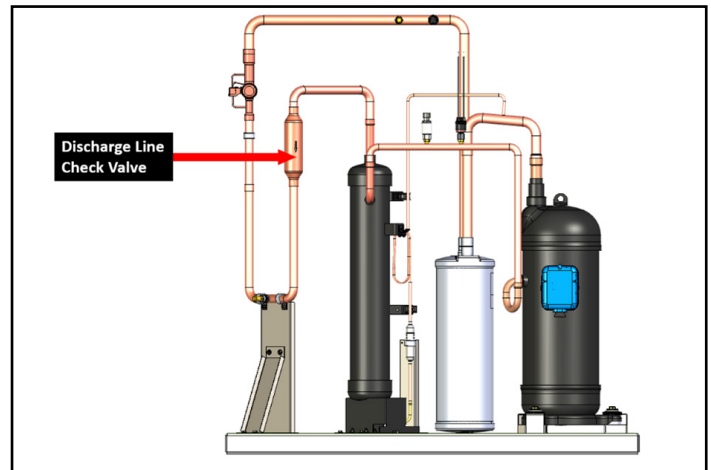

High Pressure Switch

All Rebel units have a high pressure switch located on the discharge line for each compressor. These switches are normally closed devices that are brazed directly to the refrigerant piping. When the pressure at the switch exceeds 600 PSIG the switch will open. This opening will interrupt the control signal to the variable compressor drive or de-energize the contactor coil on the fixed speed compressor, both acts will shut down the compressors and generate an alarm.

Figure 46: High Pressure Switch

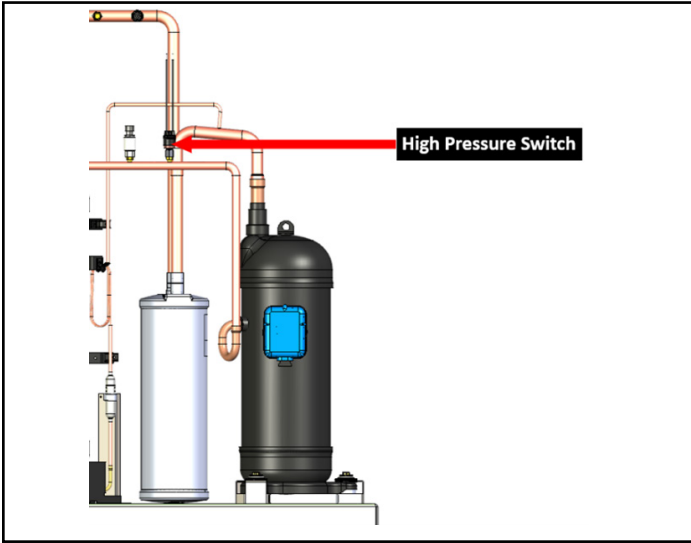

Refrigerant Screen

During manufacturing, service, and repair there is always the potential for debris to accidentally enter the sealed refrigeration system. Filter screens are positioned around the refrigerant circuit to prevent any possible debris from entering critical components; expansion valves, compressors, etc. These screens are not bi-direction and must be installed in a specific direction if replaced. Please be aware that these screens are not desiccant filters and provide no moisture protection for compromised systems.

Figure 47: Refrigerant Screen

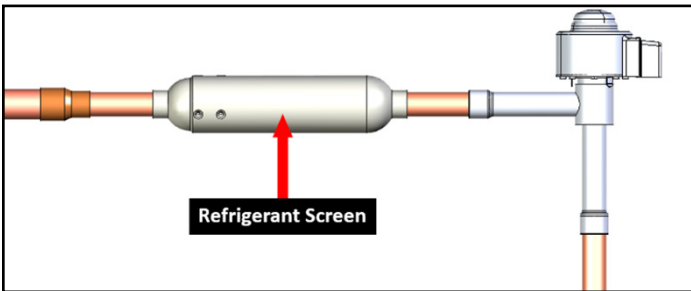

Four-Way Valve

The Four-Way Valve (4WV) also known as a Reversing Valve is a component only used on Heat Pumps. This device is used to direct the discharge gas from the compressor into the indoor coil (Heating Mode) or outdoor coil (Cooling Mode). This device is defaulted to cooling and when de-energized will direct the discharge gas into the outdoor coil.

Figure 48: Four-Way Valve

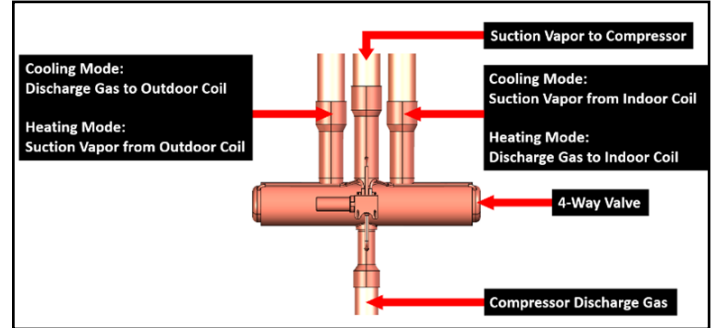

Reheat Bleed Valve

Units with modulating hot gas reheat have a bleed solenoid. This prevents refrigerant charge from becoming trapped inside the reheat coil when the unit transition back into cooling.

Indoor Expansion Valve

The Indoor Expansion Valve (EVI) is a 12 VDC stepper motor driven valve, used in heating and cooling mode.

Figure 49: Indoor Expansion Valve

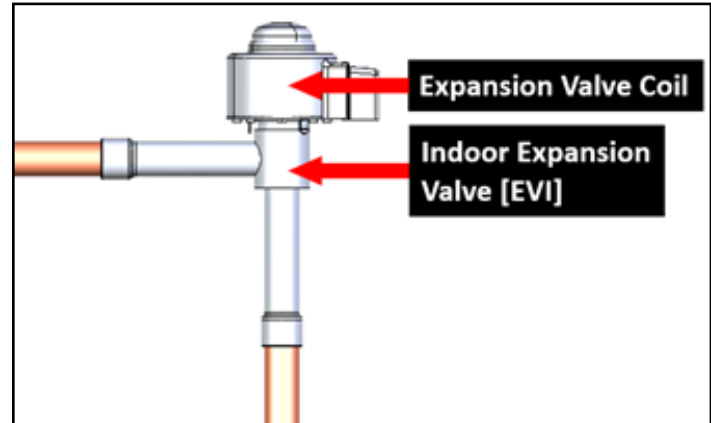

Suction Pressure Transducer

The Suction Pressure Transducer (PTS) is a refrigerant pressure sensor that screws onto a Schrader fitting on the suction line.

Discharge Pressure Transducer

The Discharge Pressure Transducer (PTD) is a refrigerant pressure sensor that screws onto a Schrader fitting on the discharge line of the compressor system.

Discharge Refrigerant Temperature

All Rebel units will have a Discharge Refrigerant Temperature Sensor (DRT) on the discharge line of each compressor. This sensor is attached the piping with a metal clip and wrapped in insulation. The purpose of this device is to increase compressor life by preventing it from running outside of the operating envelope.

Suction Refrigerant Temperature

All Rebel units will have a Suction Refrigerant Temperature Sensor (SRT). This sensor is used to determine the suction super heat entering the compressor.

Defrost Temperature Sensor

Only Rebel Heat Pump, DPSH, units will have a Defrost Temperature Sensor (DFT). This sensor is used in Heating Mode and Defrost Mode to determine the amount of frost accumulated on the Outdoor Coil.

Heating

The unit's heating mode of operation is determined by the control temperature and the heating setpoint temperature. The unit enters the heating mode of operation by comparing the control temperature to the heating setpoint.

The control temperature can be either the return temperature or the space temperature.

The return temperature is typically used for VAV units and the space temperature is typically used for CAV units.

The unit goes into the heating mode of operation when the control temperature (return or space temperature) is below the heating setpoint by more than $\frac{1}{2}$ the deadband.

For example, a standard air conditioning unit with supplemental gas, electric, or hot water heat with a heating setpoint of 68.0°F and a deadband of 1.0°F would enter heating mode if the control temperature reached 67.4°F. When this takes place, the heating mode of operation will begin and the 1st Stage of heating operation will start.

Heat Pump

The heating mode of operations will be slightly different for heat pump units. It is the manufacturer's recommendation that all Rebel heat pump units be purchased with supplemental gas, electric, or hot water heat. When the control temperature drops below the heating setpoint by half the deadband the unit will energize the four way valve and initiate mechanical heating.

On heat pumps mechanical heating is the primary source of heat and will always be the unit's first attempt to meet the application's load. After start-up the compressors will ramp up to meet the DAT Setpoint. If the mechanical heating capacity at the ambient conditions is capable of meeting the building load the variable speed compressor will stabilize at some value. If the heat pump's capacity is insufficient at the ambient conditions the supplemental (gas, electric, hot water) heat will be enabled and gradually ramp/stage on to make up the capacity shortage. If the combined capacity of the heat pump's mechanical and supplemental

heating is greater than the building load the supplemental supply will ramp/stage down. The unit will always seek to operate with mechanical heating as much as possible.

Periodically during heating operations the unit will need to enter defrost to remove frost build up from the outdoor coil. During defrost mechanical heating will be unavailable and the supplemental heat will ramp/stage up to meet the DAT set-point.

Defrost

Defrost is a temporary and infrequent period during normal heating operations on Rebel heat pumps. The purpose of defrost is to remove frost that has built up on the outdoor coil during mechanical heating. In heating mode the outdoor coil acts as an evaporator to "pull" heat out of the ambient air. As a result the surface temperature of the outdoor coil is below the ambient temperature and depending on conditions maybe below freezing. During prolonged mechanical heating while the surface temperature of the outdoor coil is below 32°F, dew point frost will form.

The defrost operation is similar to mechanical cooling. In defrost the four way valve will de-energize and the hot gas from the compressor will be forced into the outdoor coil, rejecting heating to the ambient, and melting any frost formed on the coil. To speed up the melting process during a defrost cycle the OA damper will close and the outdoor fan will de-energize. During this period the supplemental (gas, electric, hot water) heat will ramp/stage up to maintain the unit's DAT Setpoint.

Rebel heat pump unit's have demand based defrost control and will operate in defrost only as long as necessary to remove frost from the outdoor coil.

Charging

Rebel units have advanced charge management systems that make many common techniques for determining over or under charged conditions obsolete. The charge management system means that super heat and subcooling values will float to achieve the peak real time energy efficiency possible at current operating conditions (building load and ambient temperature). Rebel units also use electronic expansion valves that can not be adjusted manually. Refrigerant should never be added or removed from the system based on the desire to achieve an arbitrary subcooling value. It will always be Daikin Applied's recommendation that unit's suspected of being over/under charged have all of their refrigerant removed, leak tested with nitrogen, and then re-charged based on the unit name plate.

Fixed Speed Compressor (DPS 020–31 Only)

Unlike the variable speed compressor, the Fixed Speed Compressor has the suction line on the side of the dome entering the scrolls and a discharge exiting from the top of the shell.

Figure 50: Fixed Speed Compressor Suction and Discharge on DPS 020-31 Units

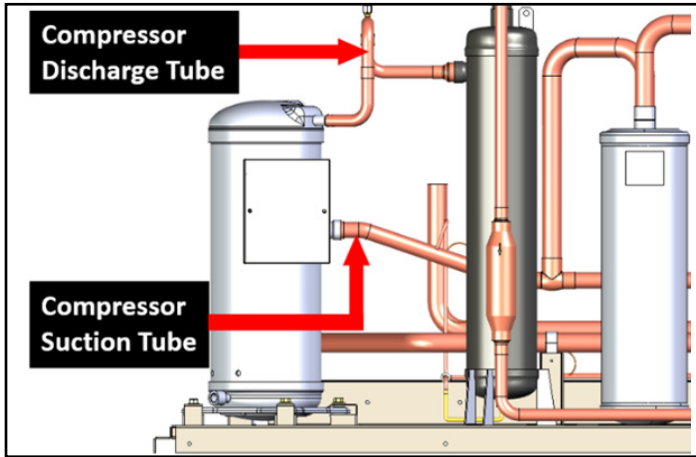

High Pressure Switch

All Rebel units have a high pressure switch located on the discharge line for each compressor. HP1 switch is on the variable speed compressor (VCmp1) and HP3 is on the fixed speed compressor (C1FCmp3). These switches are normally closed devices that are brazed directly to the refrigerant piping. When the pressure at the switch exceeds 600 PSIG the switch will open. This opening will interrupt the control signal to the variable compressor drive or de-energize the contactor coil on the fixed speed compressor. Both acts will shut down the compressors and generate an alarm at the MicroTech unit controller keypad.

Figure 51: High Pressure Switch

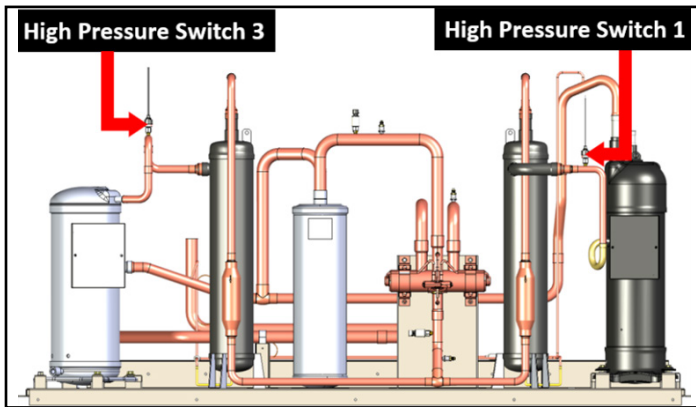

Secondary Oil Separator

On DPS 20-31 units, a fixed speed compressor and a secondary oil separator are added to the circuit. The oil separator will remove oil from the compressor discharge gas and return it to the compressor suction line. The oil separator has three lines connected to it. The connection on the side of the compressor is where the discharge gas enters. The hot gas continues on to the outdoor coil from the connection on the top of the separator. Since there are two separators, the outlet lines are connected before entering the 4WV. On the bottom is a small drain through which the oil returns after separation to the compressor suction. The refrigerant and oil path through the separator will not change whether in Heating or Cooling Mode.

Figure 52: Secondary Oil Separator

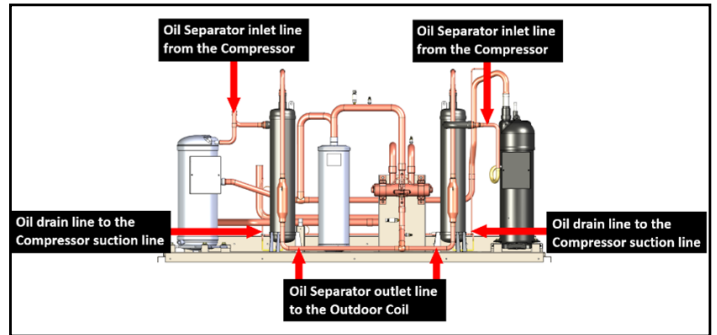

Compressor Overload

On A-Cabinet (3,4,5, and 6T) units, there is a thermal overload with a manual reset switch on the compressor. When this thermal overload exceeds 257°F, the switch will open, and the compressor will shut off. The switch will automatically reset when the temperature drops below 230°F.

Figure 53: Compressor Schematic

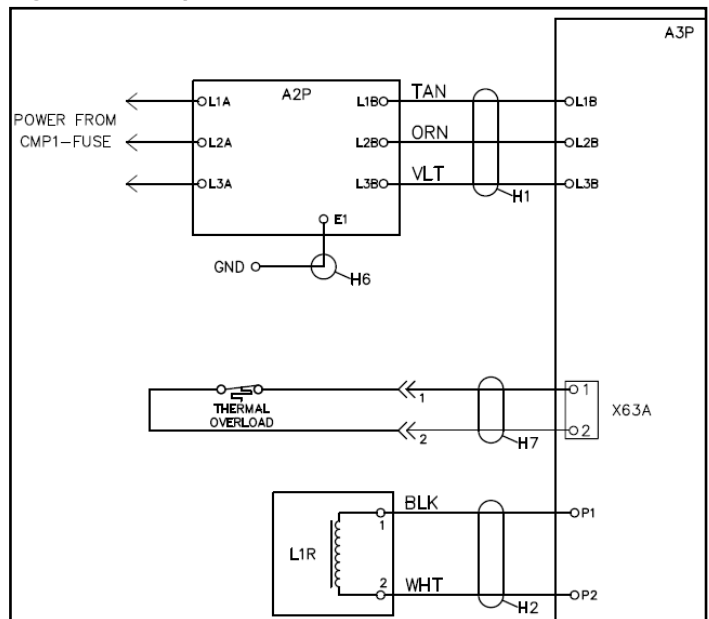

A2L Mitigation Sequences

The MT6210 A2L Leak Mitigation Controller has 4 states (Start, Run, Alarm, and Fault) and 4 connection types (Alarm Relays, Alarm Digital Output, Fault Digital Output, Customer Connection Relay). The startup state communicates that the A2L board is in start-up mode through the MicroTech interface. This shall include the time for the MT6210 internal tests and the time interval needed for the A2L leak detection sensors to report a "Run" state.

In the "Run" state, the MT6210 shall communicate a run confirmation directly through the unit controller. "Run" state is also indicated when both the Alarm and Fault Digital Output are high. "Run" state confirms all sensors are warmed up and there are no faults or alarms. If one or more leak detection sensors indicates a LFL level above the alarm threshold or sends an alarm condition, the board shall enter alarm mode in less than 2 seconds. Alarm mode shall be maintained for 5 minutes after the sensor alarm is cleared. The MT6210 shall enter fault mode if any of the following states occur:

- Loss of communication to any sensor
- Sensor reports a fault state resulting from a failed self-test
- Modbus communications are lost with the unit controller

Table 13: MT6210 A2L Leak Mitigation Controller State Matrix

MT6210 A2L Control Board State Matrix		Board States				
		No Power	Start-up	Run	Fault	Alarm
Out- puts	Alarm Relay	Open	Closed	Closed	Closed	Open
	Alarm Digital Output	Low	High	High	High	Low
	Fault Digital Output	Low	High	High	Low	High
	Customer Connection Relay	Open	Open	Open	Open	Closed
<p>If a leak is detected, the relay for the supply air fan will energize or de-energize depending on conditions shown in this table.</p> <p>Shaded cells represent de-energized relays (Off).</p> <p>Non-shaded cells represent energized relays (On).</p>						

Modulating Hot Gas Reheat

Optional Modulating Hot Gas Reheat

The reheat coil option comes complete with an aluminum micro channel coil and a modulating hot gas valve for leaving air temperature control. On a call for dehumidification, the unit will enable the supply to be over-cooled by the DX coil. Hot gas from the unit condenser will be routed to an indoor coil downstream of the DX coil to reheat the air. The hot gas reheat valve will control how much hot gas is routed to the indoor coil to maintain a discharge air setpoint.

Figure 54: 3-Way Valve Refrigeration Schematic (Cooling Model Shown)

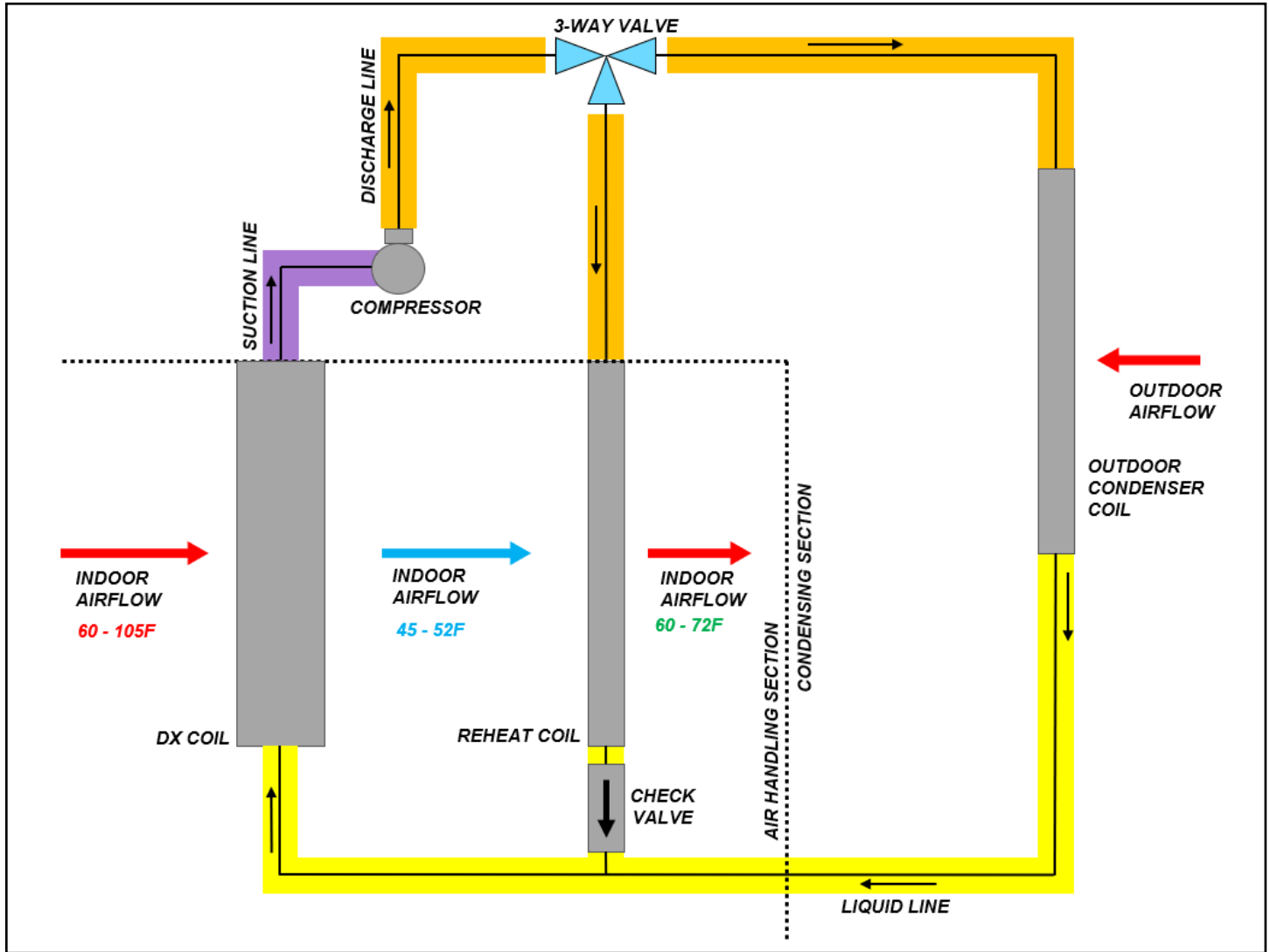
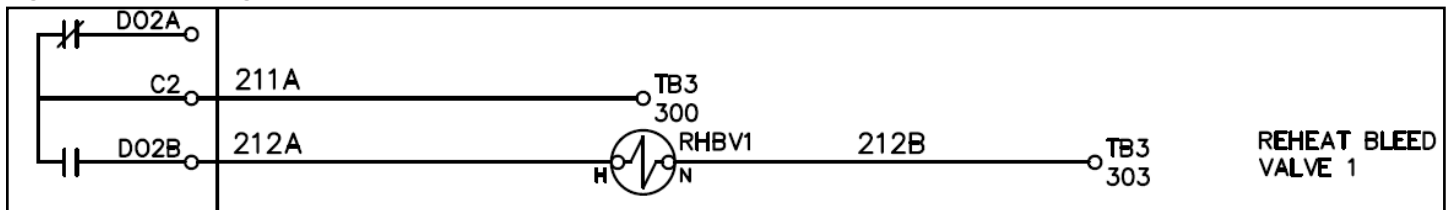

Figure 55: Modulating Hot Gas Reheat Schematic



Dehumidification Initiation

An analog sensor is mounted in the return duct, the space, or outdoors to sense Relative Humidity. The location is selected by setting the Sensor Location value on the keypad to Return, Space, or OAT. OAT can only be selected for units with DAT control. Dehumidification is disabled when the unit is in either the Heating or Minimum DAT state. When Dehumidification is enabled, Dehumidification operation is initiated when Humidity Control is set to either Relative Humidity or Dew Point and that value rises above the appropriate setpoint by more than half its deadband. Economizer operation is disabled in the Dehumidification mode so the unit immediately transitions to Cooling if Dehumidification is initiated in Economizer state.

Dehumidification Termination

Dehumidification is terminated if the selected variable, Relative Humidity or Dew Point, drops below the appropriate humidity setpoint by more than half its deadband. Dehumidification is also terminated if cooling is disabled for any reason or the unit enters either the Heating or Minimum DAT state. For units with compressors, the number of cooling stages is reduced by one and control reverts to normal control when dehumidification is terminated in the Cooling state. Another compressor stage change could then occur after one Cooling Stage Time has elapsed.

Control and Arrangement

In conjunction with dehumidification, MHGRH is used to raise the temperature of the cooled air to a desirable value. MHGRH is comprised of a parallel coil arrangement, with dual reheat valves (which operate in concert with one another) and a check valve.

During Dehumidification control with modulating Hot Gas Reheat (MHGRH) is controlled as follows:

- A PI Loop is used to control the HGRH valves to maintain the Discharge Air Temperature from the reheat coil.
- Compressor staging during reheat (or dehumidification) will be controlled by the Leaving DX Coil Temperature. For increased dehumidification during reheat, the standard default compressor staging range is 45 - 52°F.
- When dehumidification is active in the Cooling state, the reheat set point equals the DAT Cooling Setpoint. For DAT units, this is the normal DAT set point resulting from any reset. For Zone Control units, this set point is the result of a PI Loop based on the Control Temperature.
- Communication with the reheat control valves is accomplished through stepper motor drivers (built in to MCB-EME).
- In the Fan Only state, no sensible cooling is required, but dehumidification mode will still be enabled if the dew point or humidity sensor is not satisfied. Reheat set point varies from a maximum value (default 65°F) when the Control Temperature is at or below the heating changeover setpoint to a minimum value (default 55°F) when the Control Temperature is at or above the cooling changeover setpoint.
- In the reheat mode, the minimum position for the reheat valves is 1%. The controller will modulate the reheat valves from this starting position.
- Upon termination of dehumidification (reheat), the maximum ramp down or decay rate of the reheat control valves shall be 1% per sec.
- Upon termination of dehumidification (reheat), staging of compressor(s) is delayed for 1 minute after reheat capacity = 0%.
- Every 24 hours, the reheat control valves will be driven to their maximum position and then returned to their normal operating position. If unit is operating in cooling or dehumidification (reheat) at the prescribed time it will be deferred to the next time.
- Dehumidification status can now be found under the MicroTech main system menu. Reheat capacity (valve position) can also be found under the main system menu, display based on percentage (0-100%).

Optional Electric Heat

Electric Heater Design

If the 21st digit in the model number is an “E”, the rooftop unit was furnished with a factory installed electric furnace (Example, DPSH20BCPB44AA0D20BCE). The Rebel rooftop units are available with 4-stage heat output. This packaged electric heat rooftop unit is designed for outdoor non-residential installations only.

The electric heat design consists of a heating coil, staging control, and all operational safeties. The safety switches include high-limit temperature switches and individual coil fusing.

The high limit switch is an automatic reset switch. It opens the control circuit and shuts the heater down when the temperature reaches the high limit switch closes again allowing the heater to run when the temperature gets below dead band. There is a second level of protection with an auxiliary high limit switch. This switch opens up and shuts the heater down when the temperature exceeds the set point. This switch requires a manual reset.

NOTE: It is not recommended to utilize the auxiliary electric heat as a reheat source for space control.

Electric Heating Capacity Data

Table 14: Heating Capacity – Electric Heaters

Cabinet		A				B				C			
Unit		03, 004, 005, 06				07, 010, 012, 015, 17				016, 018, 020, 025, 31			
Voltage		208	230/ 240	460/ 480	575/ 600	208	230/ 240	460/ 480	575/ 600	208	230/ 240	460/ 480	575/ 600
Heater Option 1	kW	6				18				10			
	Max Amp	16.7	13.8/ 14.4	6.9/ 7.2	5.5/ 5.8	50	41.5/ 43.3	20.8/ 21.7	16.6/ 17.3	27.8	25.1/ 26.2	12.6/ 13.1	10/ 10.5
	Stage	2 or SCR	2 or SCR	2 or SCR	2 or SCR	4 or Vernier	4 or SCR	4 or SCR	4 or SCR	2 or SCR	2 or SCR	2 or SCR	2 or SCR
	Min CFM	563				2014				3500			
	Delta T	34				28				9			
Heater Option 2	kW	12				36				20			
	Max Amp	33.3	27.7/ 28.9	12.8/ 14.4	11.1/ 11.6	99.9	83/ 86.6	41.5/ 43.3	33.2/ 34.6	55.5	50.2/ 52.4	25.1/ 26.2	2.1/ 21
	Stage	2 or SCR	2 or SCR	2 or SCR	2 or SCR	4 or Vernier	4 or Vernier	4 or SCR	4 or SCR	4 or Vernier	4 or Vernier	4 or SCR	4 or SCR
	Min CFM	629				2014				3500			
	Delta T	67				53				18			
Heater Option 3	kW	18				54				30			
	Max Amp	50	41.5/ 43.3	20.8/ 21.7	16.6/ 17.3	149.9	124.5/ 129.9	62.3/ 65	49.8/ 52	83.3	75.3/ 78.7	37.7/ 39.3	30.1/ 31.5
	Stage	2 or Vernier	2 or SCR	2 or SCR	2 or SCR	4 or Vernier	4 or Vernier	4 or Vernier	4 or Vernier	4 or Vernier	4 or Vernier	4 or SCR	4 or SCR
	Min CFM	944				2831				3500			
	Delta T	80				80				27			
Heater Option 4	kW	30				72				45			
	Max Amp	83.3	69.2/ 72.2	34.6/ 36.1	27.7/ 28.9	192	159.5/ 166.4	79.7/ 83.2	63.8/ 66.6	124.9	113/ 117.9	56.5/ 58.9	45.2/ 47.2
	Stage	2 or Vernier	2 or Vernier	2 or SCR	2 or SCR	4 or Vernier	4 or Vernier	4 or Vernier	4 or Vernier	4 or Vernier	4 or Vernier	4 or Vernier	4 or SCR
	Min CFM	1573				3775				3500			
	Delta T	80				80				40			

(continued)													
Cabinet		A				B				C			
Unit		03, 004, 005, 06				07, 010, 012, 015, 17				016, 018, 020, 025, 31			
Voltage		208	230/ 240	460/ 480	575/ 600	208	230/ 240	460/ 480	575/ 600	208	230/ 240	460/ 480	575/ 600
Heater Option 5	kW	-	-	-	-	-	-	-	-	60			
	Max Amp	-	-	-	-	-	-	-	-	166.5	150.6/ 157.1	75.3/ 78.5	60.3/ 62.8
	Stage	-	-	-	-	-	-	-	-	4 or Vernier	4 or Vernier	4 or Vernier	4 or Vernier
	Min CFM	-	-	-	-	-	-	-	-	3500			
	Delta T	-	-	-	-	-	-	-	-	54			
Heater Option 6	kW	-	-	-	-	-	-	-	-	72			
	Max Amp	-	-	-	-	-	-	-	-	191.8	180.7/ 188.6	90.4/ 94.3	72.3/ 75.4
	Stage	-	-	-	-	-	-	-	-	4 or Vernier	4 or Vernier	4 or Vernier	4 or Vernier
	Min CFM	-	-	-	-	-	-	-	-	3775			
	Delta T	-	-	-	-	-	-	-	-	65			
Heater Option 7	kW	-	-	-	-	-	-	-	-	90			
	Max Amp	-	-	-	-	-	-	-	-	249.8	225.9/ 235.8	113/ 117.9	90.4/ 94.3
	Stage	-	-	-	-	-	-	-	-	4 or Vernier	4 or Vernier	4 or Vernier	4 or Vernier
	Min CFM	-	-	-	-	-	-	-	-	4718			
	Delta T	-	-	-	-	-	-	-	-	80			
Heater Option 8	kW	-	-	-	-	-	-	-	-	-	-	120	
	Max Amp	-	-	-	-	-	-	-	-	-	-	150.6/ 157.2	120.5/ 125.8
	Stage	-	-	-	-	-	-	-	-	-	-	4 or Vernier	4 or Vernier
	Min CFM	-	-	-	-	-	-	-	-	-	-	6291	
	Delta T	-	-	-	-	-	-	-	-	-	-	80	
Heater Option 9	kW	-	-	-	-	-	-	-	-	-	-	150	
	Max Amp	-	-	-	-	-	-	-	-	-	-	184/ 192	150.6/ 157.1
	Stage	-	-	-	-	-	-	-	-	-	-	4 or Vernier	4 or Vernier
	Min CFM	-	-	-	-	-	-	-	-	-	-	7864	
	Delta T	-	-	-	-	-	-	-	-	-	-	80	

NOTE 1: Minimum CFM is based on 250 FPM face velocity time face area or CFM required to get to 60°F rise which ever is higher.

NOTE 2: Select heaters will be allowed to ramp up to full capacity (100%) below when the ambient temperature is below 20°F.

NOTE 3: SCR and Vernier are very similar 0-100% controllers with Vernier being the option for high amperage situations.

NOTE 4: Control signal for SCR is 1.94-8.40VDC, for SCR Vernier is 1.00-9.00VDC.

Optional Gas Heat

Daikin Applied Tubular Heater Series

Package Heater Module

ANSI Z83.8-2013/CSA 2.6-2013

⚠ WARNING

FIRE OR EXPLOSION HAZARD

LOCKOUT/TAGOUT all power sources prior to installing the gas furnace. Failure to follow warnings exactly could result in serious personal injury, death, or property damage. Be sure to read and understand the installation, operation, and service instructions within this manual. Improper installation, adjustments, alterations, service, or maintenance can cause serious personal injury, death, or property damage.

- Do not store or use gasoline or other flammable vapors or liquids in the vicinity of this appliance.

WHAT TO DO IF YOU SMELL GAS

- Do not try to light any product that is fueled by or contains an open flame.
 - Do not touch any electrical switch.
 - Do not use any telephone in the building.
 - Leave the building immediately.
 - Immediately call the gas supplier from a remote telephone and follow the gas supplier's instructions.
 - If you cannot reach the gas supplier, call the local fire department or 911.
- Installation and service must be performed by a qualified installer, service agency, or gas supplier.

⚠ WARNING

RISQUE D'INCENDIE OU D'EXPLOSION

Le non respect des mises en garde pourrait entrainer des blessures graves, la mort ou des pertes materielles. Prendre soin de lire et de comprendre les instructions d'installation, de fonctionnement et d'entretien contenues dans ce guide. Une installation, un réglage, une modification, une réparation ou un entretien inapproprié peut entrainer des blessures graves, la mort ou des pertes materielles.

- Ne pas entreposer ni utiliser d'essence ou autre vapeurs ou liquides inflammables a proximite de cet appareil ou de tout autre appareil.

QUE FAIRE SI VOUS SENTEZ UNE ODEUR DE GAZ

- Ne tentez pas d'alumer un appareil.
 - Ne touchez pas a un interrupteur; n'utilisez pas de telephone dan l'edifice ou vous trouvez.
 - Sortez de l'edifice immediatement.
 - Appelez immediatement le fournisseur de gaz a partir d'un telephone a l'exterieur de l'edifice. Suivez les instructions du fournisseur de gaz.
 - Si vous ne pouvez joindre le fournisseur de gaz, appelez les pompiers.
- L'installation et les reparations doivent etre confiees a un installateur qualifie ou au fournisseur de gaz.

⚠ WARNING

Ensure gas furnace flues do not discharge near the fresh air intake of any other equipment or building opening.

⚠ WARNING

Unit equipped with gas heating must not be operated in an atmosphere contaminated with chemicals which will corrode the unit, such as halogenated hydrocarbons, chlorine, cleaning solvents, refrigerants, swimming pool exhaust, etc. Exposure to these compounds may cause severe damage to the gas furnace and result in improper or dangerous operation. Operation of the gas furnace in such a contaminated atmosphere and will void all warranty coverage by the manufacturer. Questions regarding specific contaminants should be referred to your local gas utility.

NOTICE

Furnace modules are a recognized furnace component design certified by Intertek Testing Services (ETL).

For outdoor installation and installation downstream from refrigeration systems in cabinet applications.

NOTICE

The unit should be installed so that the fresh air has unimpeded access to the louvered furnace fresh air intake.

This furnace must be installed in the designated non-combustible heat chamber of the cabinet. If it is removed, it is only to be replaced with an approved Original Manufacture Equipment Supplier furnace(s), installed and operated as specified by the approved Original Manufacture Equipment Supplier. It is not designed to have any portion of the heat exchanger outside the cabinet in which the furnace module is housed. This equipment must be installed, operated, and serviced only by an experienced installation company and fully trained personnel.

A Rating Plate/Name Plate has been permanently attached to the furnace assembly. It contains information including gas type, maximum and minimum input rating, manifold pressure, maximum and minimum inlet gas pressure, maximum and minimum airflow requirements, output capacity and electrical rating for the furnace. The plate also includes model number, serial number and scan code. This plate is to always remain attached to the furnace.

This furnace must be applied in accordance with the requirements of its listing.

Hooded and screened openings for combustion air have been provided in the furnace(s) access door. The access door provides direct access to the furnace vestibule where the burners, combustion inducer fan, ignition controls and ignition safeties are housed.

The vent discharge is sized such that it is equal to or larger than the discharge area of the combustion exhaust inducer fan.

A non-adjustable High Limit Switch will shut off the gas supply to the main burners before the outlet air reaches a temperature exceeding 250°F (121°C).

Clearance from combustibles to be no less than as listed below, where "Front" refers to the side where the furnace access door is located:

- Sides and Rear 6 in (152 mm)
- Bottom 2 in (51 mm)
- Top 6 in (152 mm)
- Front 36 in (914 mm)
- Vent Pipe 18 in (457 mm)

Do not use this package heater if any part has been under water. Immediately call a qualified service technician to inspect the heater and any gas control which has been under water.

Gas Furnace Design

The Rebel commercial rooftop units are available with either the low, medium, or high heat input furnace (see capacities in [Table 16](#)). This packaged gas heat rooftop unit is designed for outdoor non-residential installations only. Furnace to be supplied with natural gas or LP only.

The gas heat furnace design consists of a tubular heat exchanger, in-shot burner manifold with gas valve(s), induced combustion blower, gas heat DDC control module and all operational safeties. The safety switches include a high-limit temperature switch, an auxiliary high-limit switch, a combustion blower proof of airflow, and the flame roll-out switch (see [Figure 57](#)).

Figure 56: Typical Gas Heat Section

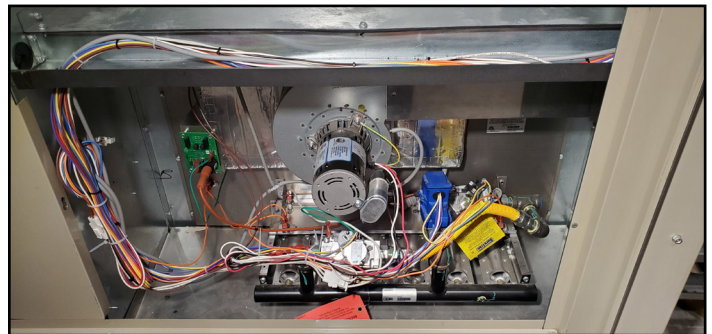

Figure 57: Typical Furnace Assembly (07-17 shown)

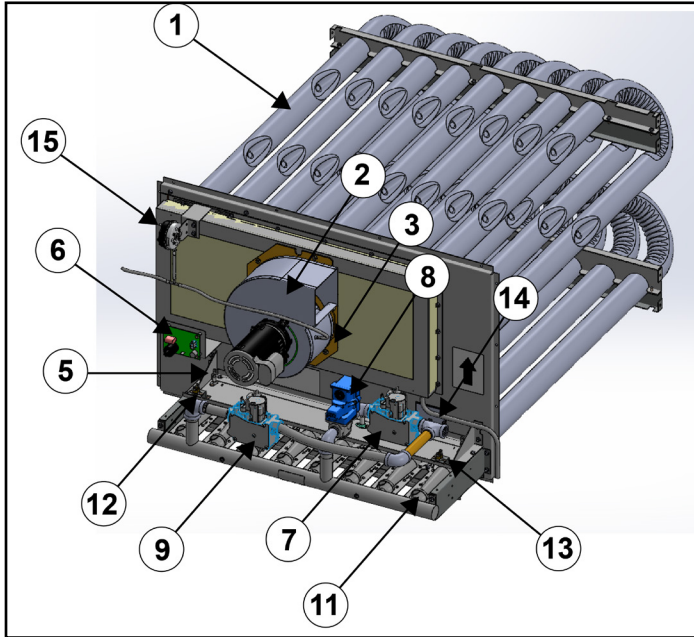
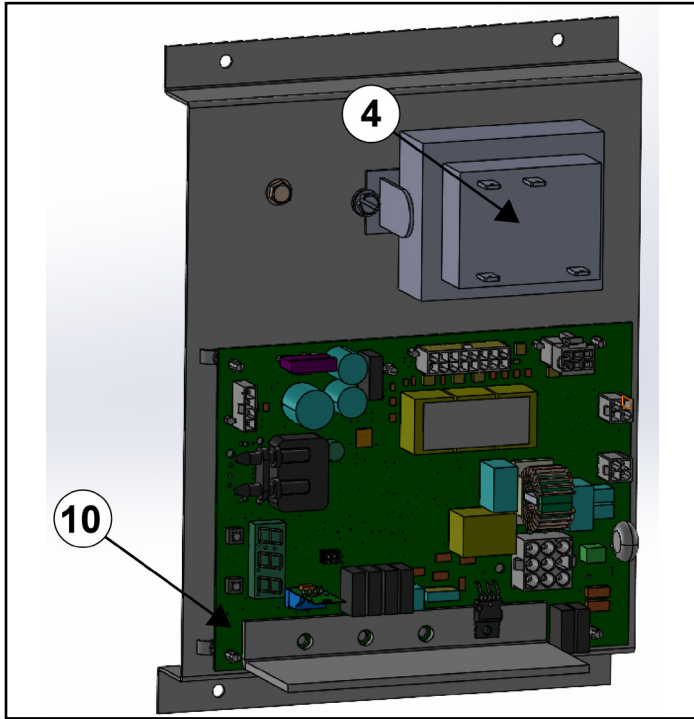

Table 15: Furnace Assembly Components Key

Item	Description
1	Heat Exchanger
2	Induced Draft Combustion Blower (Inducer)
3	Inducer Orifice Plate
4	Transformer
5	Spark Igniter
6	Ignition Control
7	Gas Safety Valve
8	Gas Modulating Valve (Not Shown)
9	Gas Staged Valve
10	VB1285 Gas Modulating Control and/or VB1287 Gas Staged Control
11	In-Shot Burner
12	Flame Roll Out Switch
13	Flame Sensor
14	High Limit Temperature Switch
15	Proof of Airflow Switch

Figure 58: Typical Controls (07-17 shown)



Ventilation and Flue Pipe Requirements

The Rebel rooftop unit is equipped with an outdoor air hood to supply adequate combustion air. The unit also has a flue outlet assembly and requires no additional chimney, flue pipe, Breidert cap, draft inducer, etc.

CAUTION

Snow levels must be controlled to prevent moisture and air flow blockage to the furnace enclosure and combustion air stream.

Flue Installation

Flue assemblies are shipped as detailed below. Remove flues from shipping straps by removing the bolts securing the strap. Straps may be discarded while strap hardware should be reinstalled in their original locations. Return to the furnace section and remove flue blank off plates. Retain hardware and use to mount flues to flue openings. A typical chimney assembly is shown in Figure 59 for reference.

NOTE: Not all cabinets follow this assembly. If chimney disassembly is required, document the disassembly to ensure correct reassembly.

Figure 59: Typical Chimney Flue Assembly

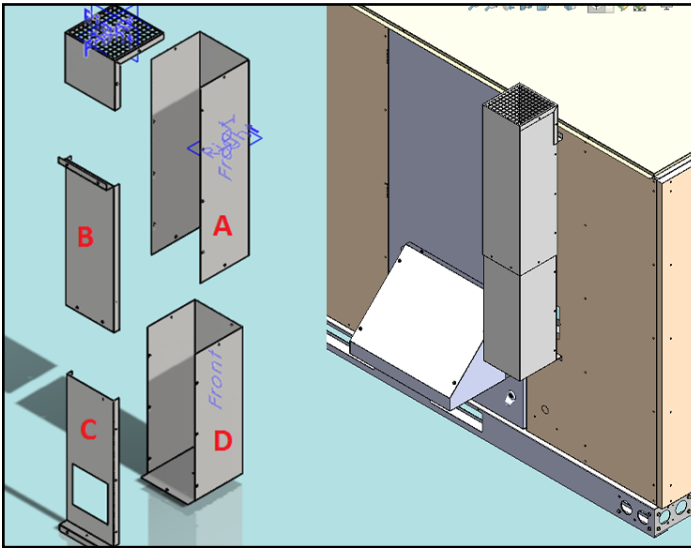

NOTE 1: A cabinet – Ships factory installed.

NOTE 2: B cabinet – Ships uninstalled but assembled and secured in supply fan section.

NOTE 3: C cabinet - Ships uninstalled but secured in condenser section.

Warranty Exclusion

Warranty is void if the furnace is operated in the presence of chlorinated vapors, if the airflow through the furnace is not in accordance with rating plate, or if the wiring or controls have been modified or tampered with.

WARNING

Hot surface hazard. Can cause severe equipment damage, personal injury, or death. Allow burner assembly to cool before servicing equipment.

WARNING

Units equipped with gas heating must not be operated in an atmosphere contaminated with chemicals which will corrode the unit such as halogenated hydrocarbons, chlorine, cleaning solvents, refrigerants, swimming pool exhaust, etc. Exposure to these compounds may cause severe damage to the gas furnace and result in improper or dangerous operation. Operation of the gas furnace in such a contaminated atmosphere constitutes product abuse and will void all warranty coverage by the manufacturer. Questions regarding specific contaminants should be referred to your local gas utility.

Horizontal Installations

WARNING

For installation on non-combustible floors only.

Rebel units are available with horizontal heat.

Installation

WARNING

Sharp edges hazard. Can cause personal injury or death. Sheet metal parts, self-tapping screws, clips, and similar items inherently have sharp edges, and it is necessary that the installer exercise caution when handling these items.

NOTICE

Connect this unit only to gas supplied by a commercial utility. This furnace must be installed by an experienced professional installation company that employs fully trained and experienced technicians. Install the gas piping in accordance local codes and regulations of the local utility company. In the absence of local codes, follow the National Fuel Gas Code, ANSI Z223.1/NFPA 54, or the CSA B149.1, Natural Gas and Propane Installation Code – latest editions. Note: The use of flexible gas connectors is not permitted.

Electrical

The Daikin Applied burner receives power and sequencing from the main unit control panel. No additional power wiring must be routed to the burner. The sequencing of the burner is also controlled through this panel and therefore is factory wired. No additional wiring will be required.

DANGER

The spark ignitor and ignition control are high voltage. Keep hands and tools away to prevent electrical shock. Shut off electrical power before servicing any of the controls. Failure to adhere to this warning can result in personal injury or death.

Auxiliary Limit Switch Function

The auxiliary limit switch is a manually resettable switch and is designed to trip in the event of a supply fan failure. It should not trip during any other conditions. In the event of a blockage to the return or discharge air, the primary limit, which is an automatic-reset type, is designed to trip.

Should there be a fan failure which results in the tripping of the auxiliary limit, the limit must be manually reset to resume function of the unit.

The auxiliary limits switches are located as indicated below:

- **Rebel A cabinet (03 - 06 ton):**
In the fan compartment between the furnace heat exchanger and the fan.
To access the switch, the fan compartment door must be opened. Be sure all power to the unit is disconnected before opening the fan compartment door. Once the fan compartment door is opened, the auxiliary limit switch can be found behind the supply fan on a bracket mounted to the cabinet wall.
- **Rebel B Cabinet (07 - 015, 17 ton):**
No auxiliary limit.
- **Rebel C Cabinet (016, 018 - 31 ton):**
In the compressor compartment above the furnace vestibule.

Depressing the red button on the auxiliary limit switch will reset the limit and allow the furnace to be powered and respond to a call for heat.

Figure 60: 3–6 Ton—Auxiliary Limit Switch

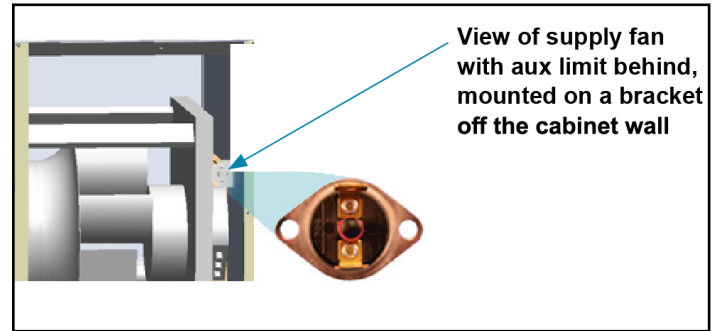
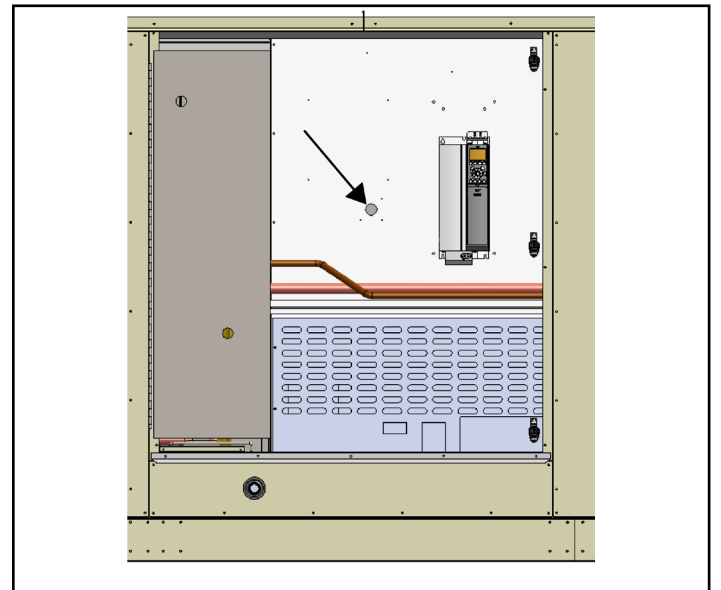

Figure 61: 17-31 Auxiliary Switch



Gas Condensate Tube

There is a evaporative condensate tube drain located on the gas assembly. Any condensate that accrues from operation will drain into the vestibule and evaporate.

NOTE: Do not trap the condensate tube drain. This would prevent proper evaporation of gas heat moisture.

Gas Heating Capacity Data

Table 16: Gas Heating Capacities (NG)

Natural Gas												
Size	Heat Size: MBH (kW)	Rated Output: MBH (kW)	Control	Rated Input, Low/High: MBH (kW)	Rated Temp Rise: °F (°C)	Minimum Airflow: CFM (m³/hr)	DAA Part Number	Supply Pressure, min-max: in W.C. (kPa)	Efficiency	Max Temp Out: °F (°C)		
A (03-06)	80 (23)	65 (19)	2 Stage	40/80 (12/23)	60 (33.3)	995 (1691)	910425001	5-14 (1.2-3.5)	81%	120 (49)		
					100 (55.6)	597 (1014)						
			5:1 Modulating	16/80 (4.7/23)	60 (33.3)	995 (1691)	910425002					
					100 (55.6)	597 (1014)						
	120 (35)	97 (28)	2 Stage	60/120 (18/35)	60 (33.3)	1493 (2537)	910450401					
					100 (55.6)	896 (1522)						
			5:1 Modulating	24/120 (7/35)	60 (33.3)	1493 (2537)	910450402					
					100 (55.6)	896 (1522)						
	160 (47)	130 (38)	2 Stage	80/160 (23/47)	60 (33.3)	1991 (3383)	910450501					
					100 (55.6)	1194 (2029)						
			5:1 Modulating	32/160 (9.4/47)	60 (33.3)	1991 (3383)	910450502					
					100 (55.6)	1194 (2029)						
B (07-015, 17)	200 (59)	160 (47)	2 Stage	100/200 (29/59)	60 (33.3)	2488 (4227)	910446801	5.5-14 (1.4-3.5)	81%	120 (49)		
					100 (55.6)	1493 (2537)						
			5:1 Modulating	40/200 (12/59)	60 (33.3)	2488 (4227)	910446803					
					100 (55.6)	1493 (2537)						
			10:1 Modulating	20/200 (5.9/59)	60 (33.3)	2488 (4227)	910446805					
					100 (55.6)	1493 (2537)						
	300 (88)	240 (71)	2 Stage	150/300 (44/88)	60 (33.3)	3733 (6342)	910446901, 910446907					
					100 (55.6)	2240 (3806)						
			5:1 Modulating	60/300 (18/88)	60 (33.3)	3733 (6342)	910446903, 910446909					
					100 (55.6)	2240 (3806)						
			10:1 Modulating	30/300 (8.8/88)	60 (33.3)	3733 (6342)	910446905, 910446972					
					100 (55.6)	2240 (3806)						
	400 (120)	320 (95)	2 Stage	200/400 (59/120)	60 (33.3)	4977 (8456)	910447001, 910447013					
					100 (55.6)	2986 (5073)					910447001, 910447007	
					5:1 Modulating	80/400 (23/120)	60 (33.3)					4977 (8456)
							100 (55.6)				2986 (5073)	910447003, 910447009
			10:1 Modulating	40/400 (12/120)	60 (33.3)	4977 (8456)	910447005, 910447017					
					100 (55.6)	2986 (5073)					910447005, 910447011	

(continued)										
Natural Gas										
Size	Heat Size: MBH (kW)	Rated Output: MBH (kW)	Control	Rated Input, Low/High: MBH (kW)	Rated Temp Rise: °F (°C)	Minimum Airflow: CFM (m³/hr)	DAA Part Number	Supply Pressure, min-max: in W.C. (kPa)	Efficiency	Max Temp Out: °F (°C)
C (016, 018-31)	300 (88)	240 (71)	2 Stage	150/300 (44/88)	60 (33.3)	3733 (6342)	910446001, 910446002	5-14 (1.2-3.5)	81%	120 (49)
				100 (55.6)	2240 (3806)					
			4 Stage	75/300 (22/88)	60 (33.3)	3733 (6342)	910446005, 910446006			
				100 (55.6)	2240 (3806)					
			12:1 Modulating	25/300 (7.3/88)	60 (33.3)	3733 (6342)	910446009, 910446010			
				100 (55.6)	2240 (3806)					
	450 (130)	360 (110)	2 Stage	230/450 (66/130)	60 (33.3)	5599 (9513)	910446101, 910446102			
				100 (55.6)	3359 (5707)					
			4 Stage	110/450 (33/130)	60 (33.3)	5599 (9513)	910446105, 910446106			
				100 (55.6)	3359 (5707)					
			12:1 Modulating	38/450 (11/130)	60 (33.3)	5599 (9513)	910446109, 910446110			
				100 (55.6)	3359 (5707)					
600 (180)	490 (140)	2 Stage	300/600 (88/180)	60 (33.3)	7465 (12683)	910446201, 910446202				
			100 (55.6)	4479 (7610)						
		4 Stage	150/600 (44/180)	60 (33.3)	7465 (12683)	910446205, 910446206				
			100 (55.6)	4479 (7610)						
		12:1 Modulating	50/600 (15/180)	60 (33.3)	7465 (12683)	910446209, 910446210				
			100 (55.6)	4479 (7610)						

Table 17: Gas Heating Capacities (Propane Gas)

Propane Gas												
Cabinet Size	Heat Size: MBH (kW)	Rated Output: MBH (kW)	Control	Rated Input, Low/ High: MBH (kW)	Rated Temp Rise: °F (°C)	Minimum Airflow: CFM (m ³ /hr)	DAA Part Number	Supply Pressure, min-max: in W.C. (kPa)	Efficiency	Max Temp Out: °F (°C)		
A (03-06)	80 (23)	65 (19)	2 Stage	40/80 (12/23)	60 (33.3)	995 (1691)	910425003	11-14 (2.7-3.5)	81%	120 (49)		
					100 (55.6)	597 (1014)						
			5:1 Modulating	16/80 (4.7/23)	60 (33.3)	995 (1691)	910425004					
					100 (55.6)	597 (1014)						
	120 (35)	97 (28)	2 Stage	60/120 (18/35)	60 (33.3)	1493 (2537)	910450403					
					100 (55.6)	896 (1522)						
			5:1 Modulating	24/120 (7/35)	60 (33.3)	1493 (2537)	910450404					
					100 (55.6)	896 (1522)						
	160 (47)	130 (38)	2 Stage	80/160 (23/47)	60 (33.3)	1991 (3383)	910450503					
					100 (55.6)	1194 (2029)						
			5:1 Modulating	32/160 (9.4/47)	60 (33.3)	1991 (3383)	910450504					
					100 (55.6)	1194 (2029)						
B (07-015, 17)	200 (59)	160 (47)	2 Stage	100/200 (29/59)	60 (33.3)	2488 (4227)	910446802	11-14 (2.7-3.5)	81%	120 (49)		
					100 (55.6)	1493 (2537)						
			5:1 Modulating	40/200 (12/59)	60 (33.3)	2488 (4227)	910446804					
					100 (55.6)	1493 (2537)						
			10:1 Modulating	20/200 (5.9/59)	60 (33.3)	2488 (4227)	910446806					
					100 (55.6)	1493 (2537)						
	300 (88)	240 (71)	2 Stage	150/300 (44/88)	60 (33.3)	3733 (6342)	910446902, 910446908					
					100 (55.6)	2240 (3806)						
			5:1 Modulating	60/300 (18/88)	60 (33.3)	3733 (6342)	910446904, 910446910					
					100 (55.6)	2240 (3806)						
			10:1 Modulating	30/300 (8.8/88)	60 (33.3)	3733 (6342)	910446906, 910446973					
					100 (55.6)	2240 (3806)						
	400 (120)	320 (95)	2 Stage	200/400 (59/120)	60 (33.3)	4977 (8456)	910447002, 910447014					
					100 (55.6)	2986 (5073)					910447002, 910447008	
					5:1 Modulating	80/400 (23/120)	60 (33.3)					4977 (8456)
							100 (55.6)				2986 (5073)	910447004, 910447010
			10:1 Modulating	40/400 (12/120)	60 (33.3)	4977 (8456)	910447006, 910447018					
					100 (55.6)	2986 (5073)					910447006, 910447012	

(continued)										
Propane Gas										
Cabinet Size	Heat Size: MBH (kW)	Rated Output: MBH (kW)	Control	Rated Input, Low/ High: MBH (kW)	Rated Temp Rise: °F (°C)	Minimum Airflow: CFM (m³/hr)	DAA Part Number	Supply Pressure, min-max: in W.C. (kPa)	Efficiency	Max Temp Out: °F (°C)
C (016, 018-31)	300 (88)	240 (71)	2 Stage	150/300 (44/88)	60 (33.3)	3733 (6342)	910446003, 910446004	11-14 (2.7-3.5)	81%	120 (49)
					100 (55.6)	2240 (3806)				
			4 Stage	75/300 (22/88)	60 (33.3)	3733 (6342)	910446007, 910446008			
					100 (55.6)	2240 (3806)				
			12:1 Modulating	25/300 (7.3/88)	60 (33.3)	3733 (6342)	910446011, 910446012			
					100 (55.6)	2240 (3806)				
	450 (130)	360 (110)	2 Stage	230/450 (66/130)	60 (33.3)	5599 (9513)	910446103, 910446104			
					100 (55.6)	3359 (5707)				
			4 Stage	110/450 (33/130)	60 (33.3)	5599 (9513)	910446107, 910446108			
					100 (55.6)	3359 (5707)				
			12:1 Modulating	38/450 (11/130)	60 (33.3)	5599 (9513)	910446111, 910446112			
					100 (55.6)	3359 (5707)				
600 (180)	490 (140)	2 Stage	300/600 (88/180)	60 (33.3)	7465 (12683)	910446203, 910446204				
				100 (55.6)	4479 (7610)					
		4 Stage	150/600 (44/180)	60 (33.3)	7465 (12683)	910446207, 910446208				
				100 (55.6)	4479 (7610)					
		12:1 Modulating	50/600 (15/180)	60 (33.3)	7465 (12683)	910446211, 910446212				
				100 (55.6)	4479 (7610)					

Manifold Diagrams

Figure 62: 2-Stage Furnaces – 1 Standard Manifold

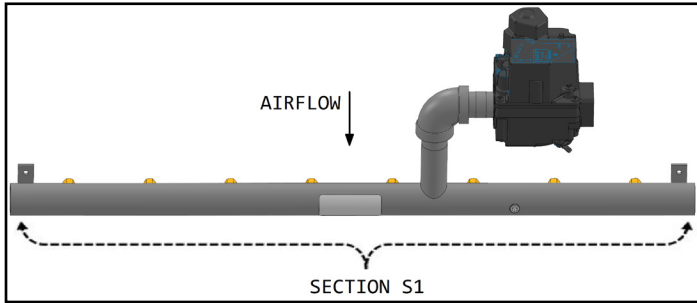

NOTE: Includes 80, 120, 160, 200, 300, 400 MBH Furnaces (MQ[812, 813, 814, 504, 506, 516, 508]TS Series Furnaces).

The noted furnaces are configured as one manifold section with one 2-stage valve. One furnace control board is supplied with this furnace module. The VB1287 control board controls the staged section (S1) of the furnace manifold as shown in Figure 62.

Figure 63: 2-Stage Furnaces – 1 Split Manifold

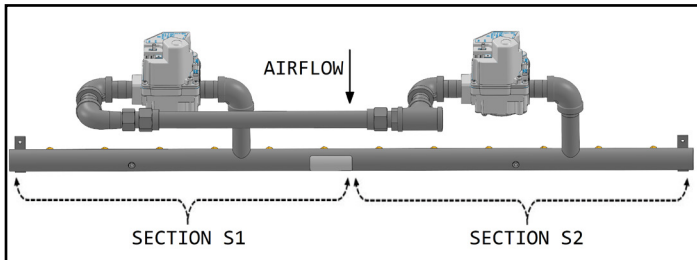

NOTE: Includes 450, 600 MBH Furnaces (MQ[519, 512]TS Series furnaces).

The noted furnaces are split into two manifold sections, each with a single 1-stage valve. One furnace control board is supplied with this furnace model. The VB1287 control board simultaneously controls both staged sections (S1 and S2) of the furnace manifold as shown in Figure 63.

Figure 64: 4-Stage Furnaces – 1 Split Manifold

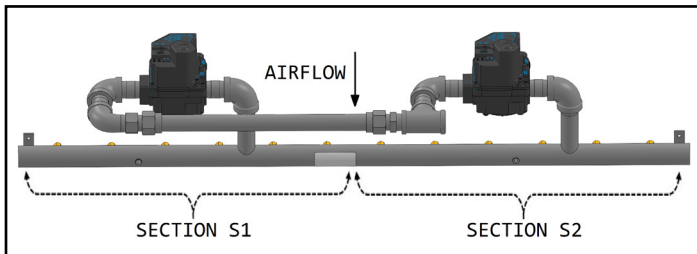

NOTE: Includes 300, 450, 600 MBH Furnaces (MQ[516, 519, 512]FS Series furnaces).

The noted furnaces are split into two manifold sections, each with one 2-stage valve. One furnace control board is supplied with this furnace model. The VB1287 control board simultaneously controls both staged sections (S1 and S2) of the furnace manifold as shown in Figure 64.

Figure 65: 5:1 Modulating Furnaces – 1 Standard Manifold

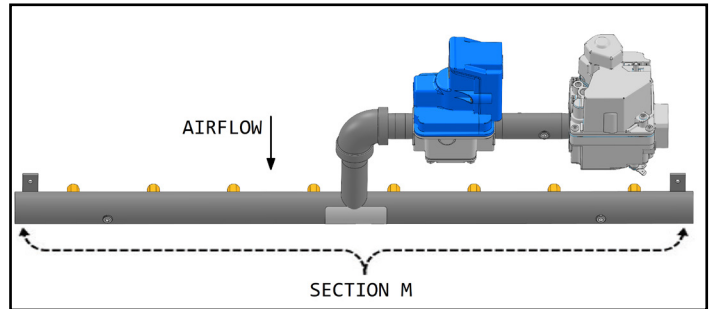

NOTE: Includes 80, 120, 160, 200, 300, 400 MBH Furnaces (MQ[812, 813, 814, 504, 506, 508]MV Series furnaces).

The noted furnaces are configured as one manifold section, with one modulating valve and one safety valve. One furnace control board is supplied with this furnace model. The VB1285 control board controls the modulating section (M) of the furnace manifold as shown in Figure 65.

Figure 66: 10:1 Modulating Furnaces – 1 Split Manifold

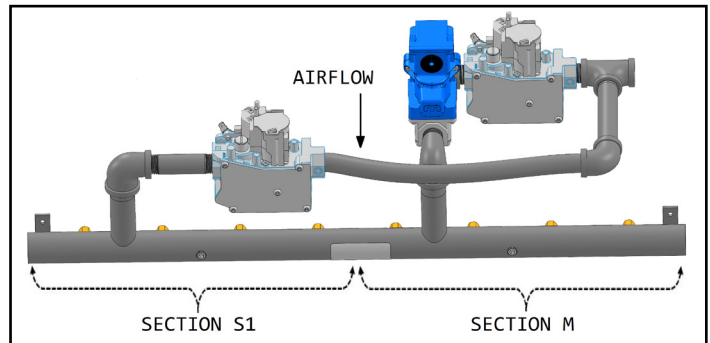

NOTE: Includes 200, 300, 400 MBH Furnaces (MQ[504, 506, 508]SP Series Furnaces).

The noted furnaces are split into two manifold sections: section M has one modulating valve and one safety valve, and section S1 has a single 1-stage valve. One furnace control board is supplied with this furnace model. The VB1285 control board simultaneously controls the modulating section (M) and the staged section (S1) of the furnace manifold as shown in Figure 66.

Figure 67: 12:1 Modulating Furnaces – 1 Uneven-Split Manifold

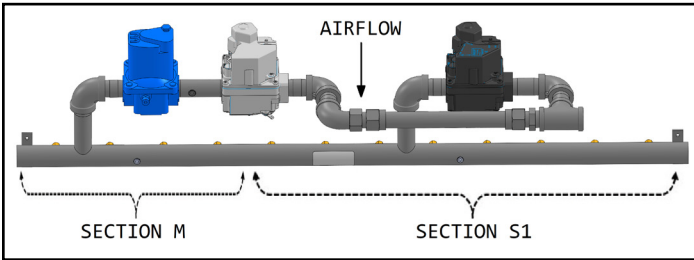

NOTE: Includes 300 , 450, 600 MBH Furnaces (MQ[516, 519, 512]SP Series Furnaces).

The noted furnaces are split into two uneven manifold sections: section M has one modulating valve and one safety valve, and section S1 has one 2-stage valve. Two furnace control boards are supplied with this furnace model. The VB1285 control board simultaneously controls the modulating section (M) and sends a signal to the VB1287 board, which subsequently controls the staged section (S1) of the furnace manifold as shown in Figure 67.

Gas Piping Routing Into Unit

⚠ DANGER

Never test for gas leaks with an open flame. It can cause an explosion or fire resulting in property damage, personal injury, or death. Use a commercially available soap solution made specifically for the detection of leaks to check all connections.

On-The-Roof Piping

1. Remove knockout on upright (refer to Figure 68, Figure 69 or Figure 70).
2. Route gas supply pipe through hole. Carefully plan pipe route and fitting locations to avoid interference with swinging of doors, etc.
3. The Rebel unit does not have an option for gas piping through the curb.
4. Field piping to be supported such that it does not generate a force (weight) and/or torque (twist) on the Factory gas manifold(s).

The appliance must be isolated from the gas supply system by closing off the manual shut off valve during any pressure testing less than 0.5 psi (3.5 kPa) of the gas supply piping system.

The appliance and its individual shut-off valve must be disconnected from the gas supply system during any pressure testing greater than or equal to 0.5 psi (3.5 kPa).

Regulator to be sized for the maximum total Btu input required for the heater(s).

Figure 68: Rebel A Cabinet (03–06) Gas Piping

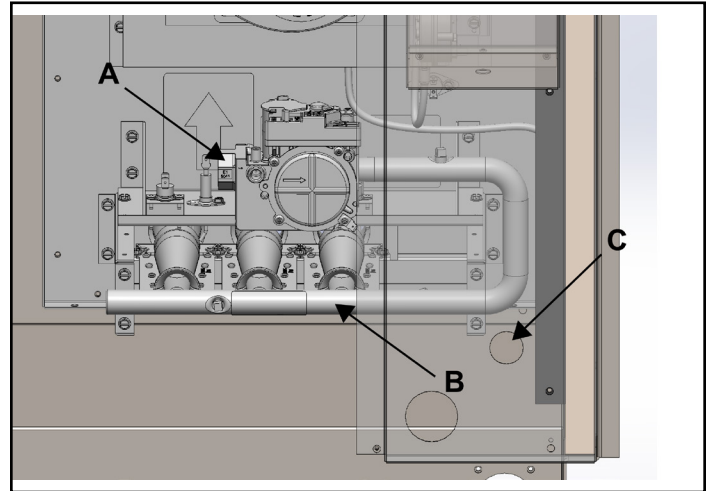

- A. Gas Supply Connection
- B. Factory Gas Manifold
- C. Field Piping Entrance

Figure 69: Rebel B Cabinet (07-17) Gas Piping

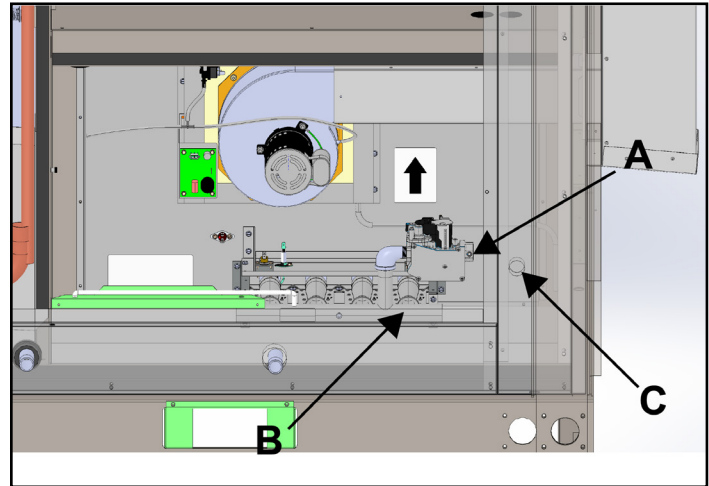

- A. Gas Supply Connection
- B. Factory Gas Manifold
- C. Field Piping Entrance

Figure 70: Rebel C Cabinet 016-31 Gas Piping

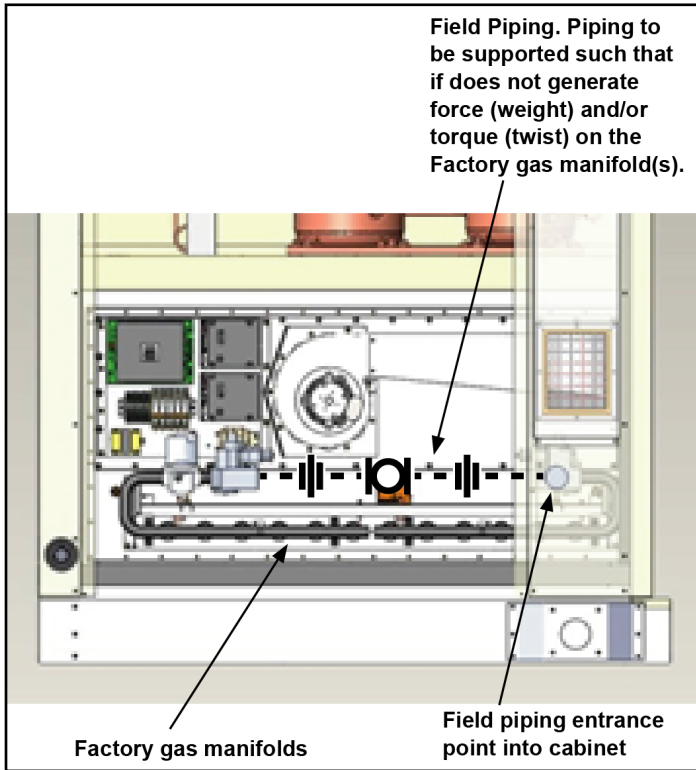
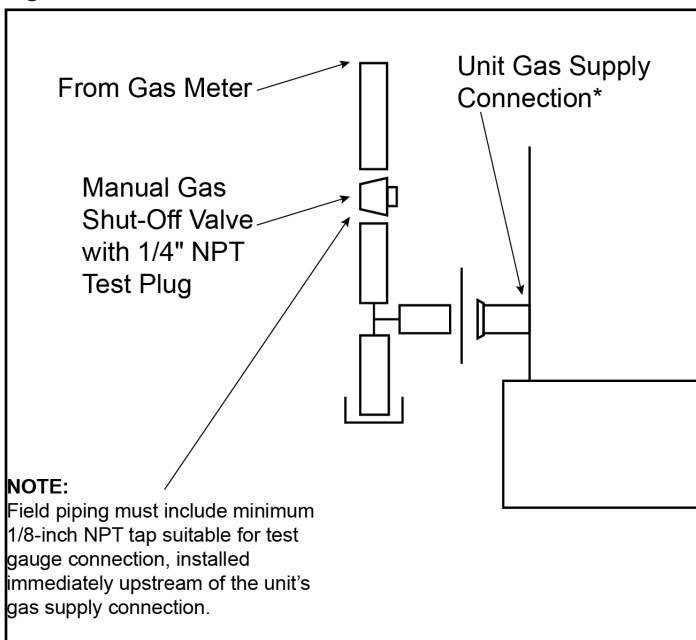

Figure 71: Field Gas Heat Connections



Gas Piping

Gas piping must be sized to provide the minimum required pressure at the burner when the burner is operating at maximum input. Consult your local utility on any questions on gas pressure available, allowing piping pressure drops, and local piping requirements. The weight of field supplied gas piping must be supported by field supplied brackets or hangers.

The proper size piping must be run from the meter to the gas burner without reductions. Undersized piping will result in inadequate pressure at the burner. The pressure will be at its lowest when it is needed the most, at times of maximum demand. Therefore, it can cause intermittent hard-to-find problems because the problem may have left before the service technician has arrived. Avoid the use of bushings wherever possible.

Remove all burrs and obstructions from pipe. Do not bend pipe; use elbows or other pipe fittings to properly locate pipe.

A drip leg and a manual shut-off must be installed in the vertical line before each burner such that it will not freeze. Install unions so gas train components can be removed for service. All pipe threads must have a pipe dope which is resistant to the action of Propane gas. After installation, pressurize the piping as required and test all joints for tightness with a rich soap solution. Any bubbling is considered a leak and must be eliminated. Do not use a match or flame to locate leaks.

Gas Pressure Requirements

The pressure furnished to the main gas valve must not exceed 14" WC. When the supply pressure is above 14" WC, a high pressure regulator must precede the appliance gas pressure regulator. The inlet gas pressure must not exceed the maximum pressure rating of the high pressure regulator, and the outlet pressure must furnish gas to the appliance pressure regulator within the pressure range mentioned above.

Table 18: Capacity of Pipe, Natural Gas (CFH)

With Pressure Drop of 0.3" WC and Specific Gravity Of 0.60									
Pipe Length (ft.)	Pipe Size-inches (Ips)								
	½	¾	1	1¼	1½	2	2½	3	4
10	132	278	520	1050	1600	2050	4800	8500	17500
20	92	190	350	730	1100	2100	3300	5900	12000
30	73	152	285	590	890	1650	2700	4700	9700
40	63	130	245	500	760	1450	2300	4100	8300
50	56	115	215	440	670	1270	2000	3600	7400
60	50	105	195	400	610	1150	1850	3250	6800
70	46	96	180	370	560	1050	1700	3000	6200
80	53	90	170	350	530	990	1600	2800	5800
90	40	84	160	320	490	930	1500	2600	5400
100	38	79	150	305	460	870	1400	2500	5100
125	34	72	130	275	410	780	1250	2200	4500
150	31	64	120	250	380	710	1130	2000	4100
175	28	59	110	225	350	650	1050	1850	3800
200	26	55	100	210	320	610	980	1700	3500

NOTE: Use multiplier below for other gravities and pressure drops.

Table 19: Specific Gravity Other Than 0.60

Specific Gravity	Multiplier
0.50	1.100
0.60	1.000
0.70	0.936
0.80	0.867
0.90	0.816
1.00	0.775
Propane-Air	
1.10	0.740
Propane	
1.55	0.622
Butane	
2.00	0.547

Table 20: Pressure Drop Other Than 0.3"

Pressure Drop	Multiplier	Pressure	Multiplier
0.1	0.577	1.0	1.83
0.2	0.815	2.0	2.58
0.3	1.000	3.0	3.16
0.4	1.16	4.0	3.65
0.6	1.42	6.0	4.47
0.8	1.64	8.0	5.15

Gas Heating Pressure Management Diagrams

Figure 72: Diagrams for Pressure Measurement Locations

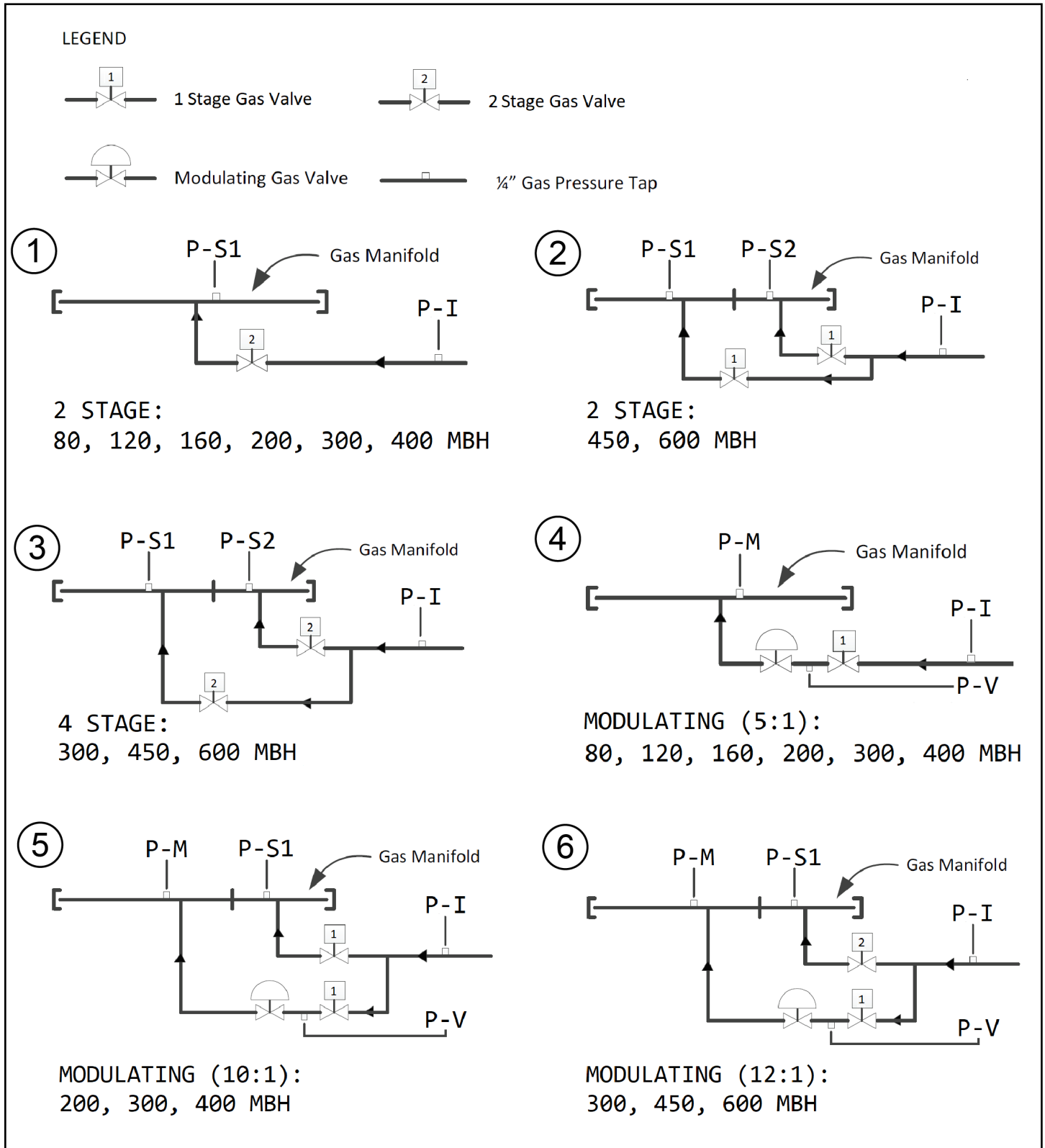

Figure 73: Staged Gas Safety Control

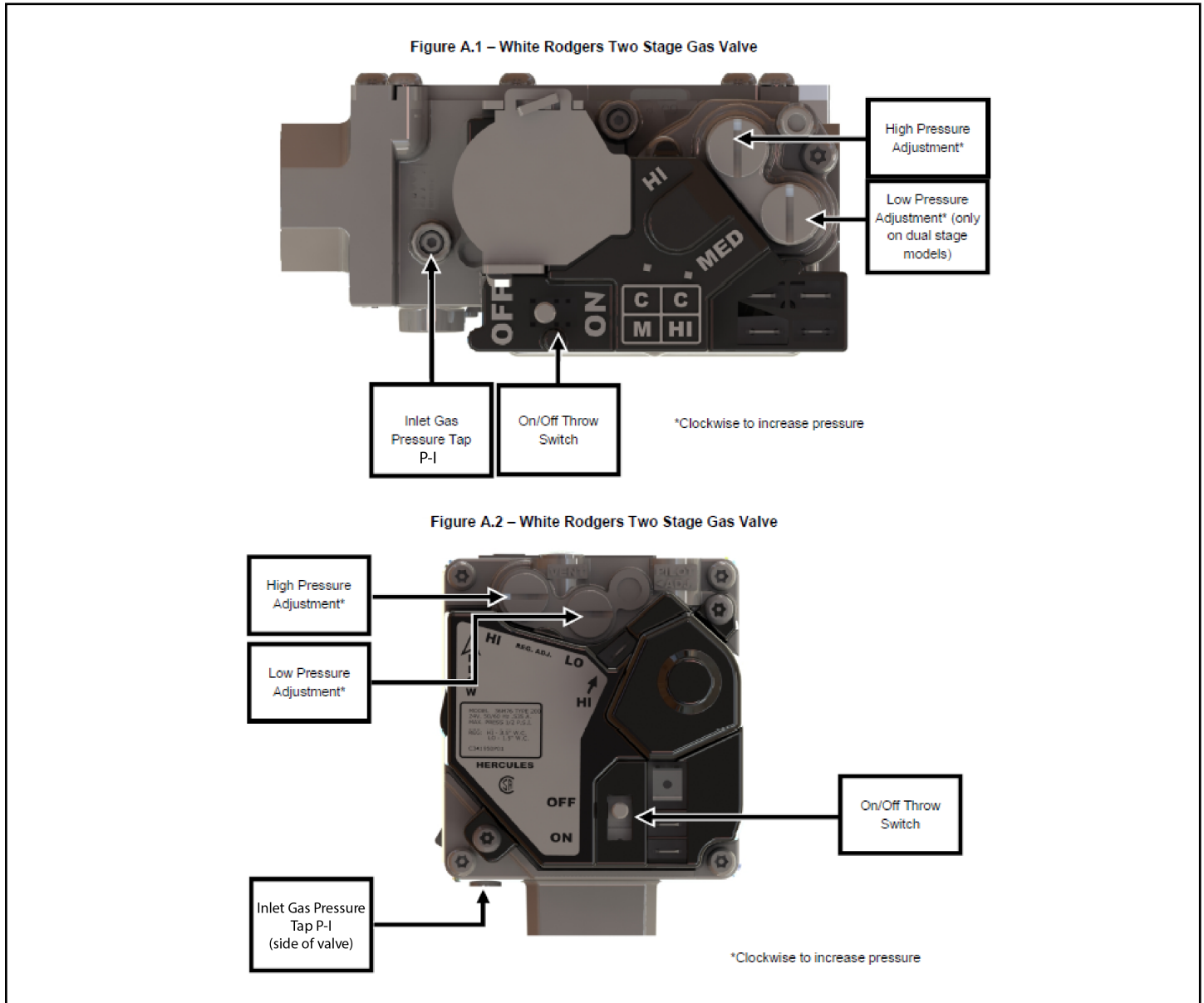

Figure 74: Outlet Pressure Port Location

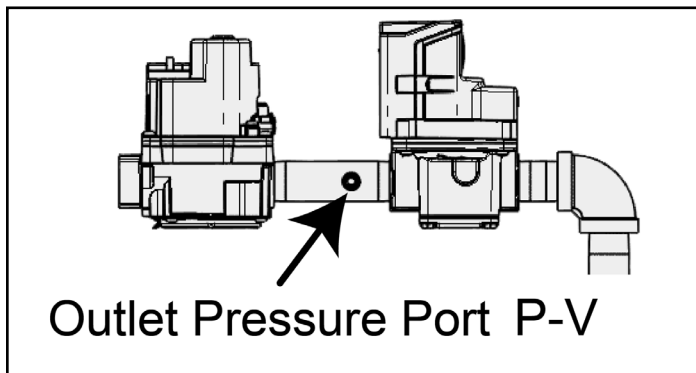

Figure 75: White Rodgers Single Stage Gas Valve (for Sections at 200 MBH and Below)

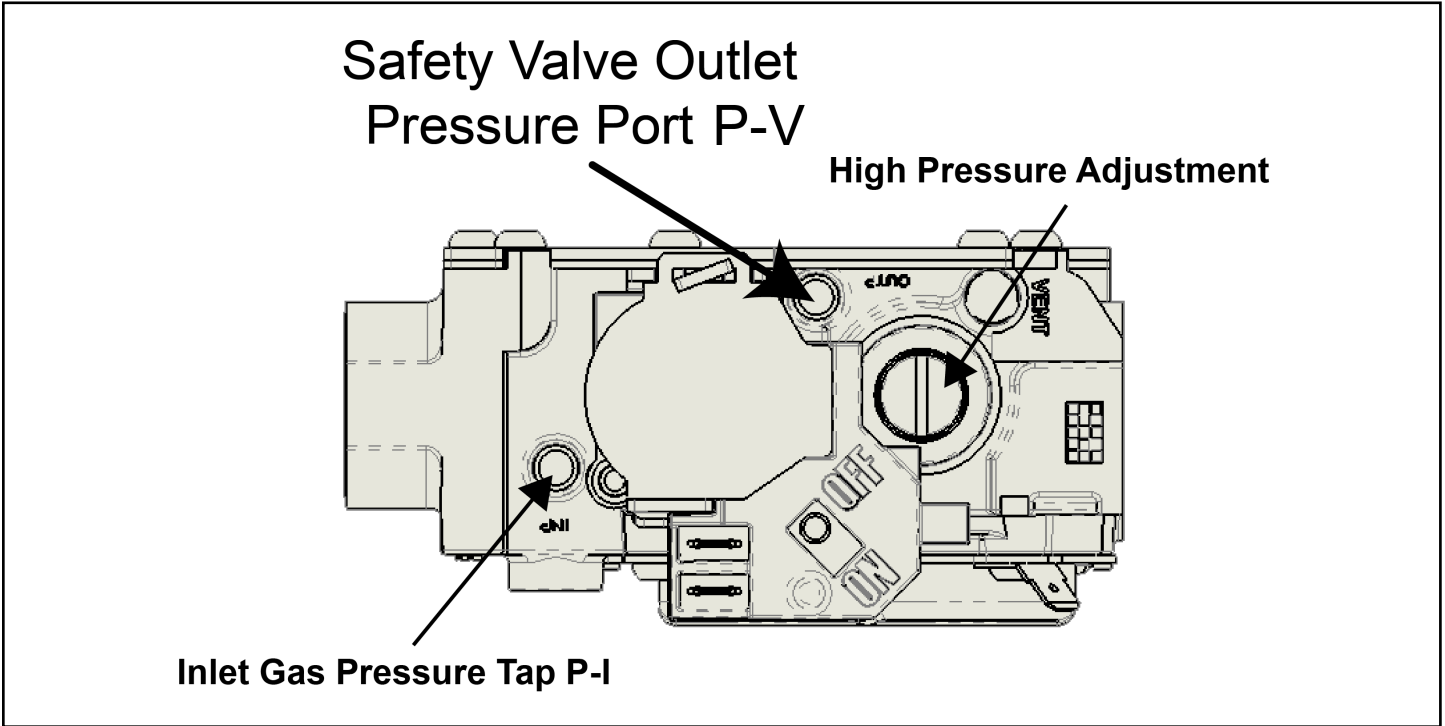
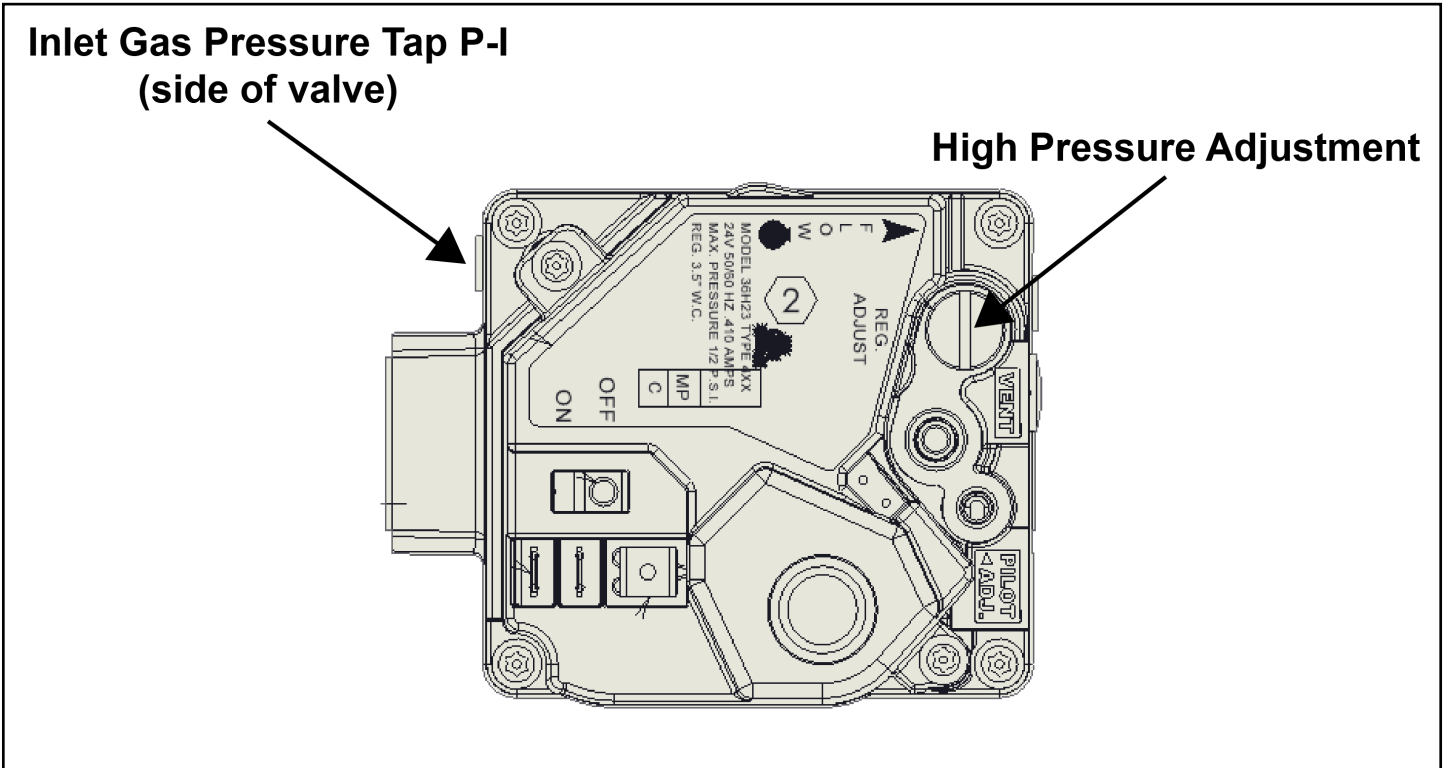

Figure 76: White Rodgers Single Stage Gas Valve (for Sections Above 200 MBH)



Gas Heating Pressure Data

Table 21: Gas Heating Pressures (Natural Gas)

Natural Gas													
Control	Cabinet	Furnace Size: MBH (kW)	Furnace PN	Figure (page 61)	Data shown as inches WC (kPa)								
					P-I	P-M, High	P-M, Low	P-S1, High	P-S1, Low	P-S2, High	P-S2, Low	P-V, Max	P-V, Min
2 Stage	A (03-06)	80 (23)	910425001	1	5 (1.2)	-	-	3.5 (0.87)	1.1 (0.27)	-	-	4.5 (1.12)	4.0 (1.00)
		120 (35)	910450401		5 (1.2)	-	-	3.5 (0.87)	1.1 (0.27)	-	-	4.5 (1.12)	4.0 (1.00)
		160 (47)	910450501		5 (1.2)	-	-	3.5 (0.87)	1.1 (0.27)	-	-	4.5 (1.12)	4.0 (1.00)
	B (07-015, 17)	200 (59)	910446801		5.5 (1.4)	-	-	3.5 (0.87)	1.1 (0.27)	-	-	4.5 (1.12)	4.0 (1.00)
		300 (88)	910446901		5.5 (1.4)	-	-	3.5 (0.87)	1.1 (0.27)	-	-	4.5 (1.12)	4.0 (1.00)
			910446907		5.5 (1.4)	-	-	3.5 (0.87)	1.1 (0.27)	-	-	4.5 (1.12)	4.0 (1.00)
		400 (120)	910447001		5.5 (1.4)	-	-	3.5 (0.87)	1.1 (0.27)	-	-	4.5 (1.12)	4.0 (1.00)
			910447007		5.5 (1.4)	-	-	3.5 (0.87)	1.1 (0.27)	-	-	4.5 (1.12)	4.0 (1.00)
			910447013		5.5 (1.4)	-	-	3.5 (0.87)	1.1 (0.27)	-	-	4.5 (1.12)	4.0 (1.00)
		C (016, 018-31)	300 (88)		910446001	5 (1.2)	-	-	3.5 (0.87)	1.1 (0.27)	-	-	4.5 (1.12)
	910446002				5 (1.2)	-	-	3.5 (0.87)	1.1 (0.27)	-	-	4.5 (1.12)	4.0 (1.00)
	450 (130)		910446101		5 (1.2)	-	-	3.5 (0.87)	-	3.5 (0.87)	-	4.5 (1.12)	4.0 (1.00)
			910446102		5 (1.2)	-	-	3.5 (0.87)	-	3.5 (0.87)	-	4.5 (1.12)	4.0 (1.00)
	600 (180)		910446201		5 (1.2)	-	-	3.5 (0.87)	-	3.5 (0.87)	-	4.5 (1.12)	4.0 (1.00)
910446202			5 (1.2)	-	-	3.5 (0.87)	-	3.5 (0.87)	-	4.5 (1.12)	4.0 (1.00)		
4 Stage	C (016, 018-31)	300 (88)	910446005	3	5 (1.2)	-	-	3.5 (0.87)	1.1 (0.27)	3.5 (0.87)	1.1 (0.27)	4.5 (1.12)	4.0 (1.00)
			910446006		5 (1.2)	-	-	3.5 (0.87)	1.1 (0.27)	3.5 (0.87)	1.1 (0.27)	4.5 (1.12)	4.0 (1.00)
		450 (130)	910446105		5 (1.2)	-	-	3.5 (0.87)	1.1 (0.27)	3.5 (0.87)	1.1 (0.27)	4.5 (1.12)	4.0 (1.00)
			910446106		5 (1.2)	-	-	3.5 (0.87)	1.1 (0.27)	3.5 (0.87)	1.1 (0.27)	4.5 (1.12)	4.0 (1.00)
		600 (180)	910446205		5 (1.2)	-	-	3.5 (0.87)	1.1 (0.27)	3.5 (0.87)	1.1 (0.27)	4.5 (1.12)	4.0 (1.00)
			910446206		5 (1.2)	-	-	3.5 (0.87)	1.1 (0.27)	3.5 (0.87)	1.1 (0.27)	4.5 (1.12)	4.0 (1.00)

(continued)													
Natural Gas													
					Data shown as inches WC (kPa)								
Control	Cabinet	Furnace Size: MBH (kW)	Furnace PN	Figure (page 61)	P-I	P-M, High	P-M, Low	P-S1, High	P-S1, Low	P-S2, High	P-S2, Low	P-V, Max	P-V, Min
5:1 Modulating	A (03-06)	80 (23)	910425002	4	5 (1.2)	3.5 (0.87)	0.2 (0.05)	-	-	-	-	4.5 (1.12)	4.0 (1.00)
		120 (35)	910450402		5 (1.2)	3.5 (0.87)	0.2 (0.05)	-	-	-	-	4.5 (1.12)	4.0 (1.00)
		160 (47)	910450502		5 (1.2)	3.5 (0.87)	0.2 (0.05)	-	-	-	-	4.5 (1.12)	4.0 (1.00)
	B (07-015, 17)	200 (59)	910446803		5.5 (1.4)	3.5 (0.87)	0.2 (0.05)	-	-	-	-	4.5 (1.12)	4.0 (1.00)
		300 (88)	910446903		5.5 (1.4)	3.5 (0.87)	0.2 (0.05)	-	-	-	-	4.5 (1.12)	4.0 (1.00)
			910446909		5.5 (1.4)	3.5 (0.87)	0.2 (0.05)	-	-	-	-	4.5 (1.12)	4.0 (1.00)
		400 (120)	910447003		5.5 (1.4)	3.5 (0.87)	0.2 (0.05)	-	-	-	-	4.5 (1.12)	4.0 (1.00)
			910447009		5.5 (1.4)	3.5 (0.87)	0.2 (0.05)	-	-	-	-	4.5 (1.12)	4.0 (1.00)
		910447015	5.5 (1.4)		3.5 (0.87)	0.2 (0.05)	-	-	-	-	4.5 (1.12)	4.0 (1.00)	
		10:1 Modulating	B (07-015, 17)		200 (59)	910446805	5	5.5 (1.4)	3.5 (0.87)	0.2 (0.05)	3.5 (0.87)	-	-
300 (88)	910446905			5.5 (1.4)	3.5 (0.87)	0.2 (0.05)		3.5 (0.87)	-	-	-	4.5 (1.12)	4.0 (1.00)
	910446972			5.5 (1.4)	3.5 (0.87)	0.2 (0.05)		3.5 (0.87)	-	-	-	4.5 (1.12)	4.0 (1.00)
400 (120)	910447005			5.5 (1.4)	3.5 (0.87)	0.2 (0.05)		3.5 (0.87)	-	-	-	4.5 (1.12)	4.0 (1.00)
	910447011			5.5 (1.4)	3.5 (0.87)	0.2 (0.05)		3.5 (0.87)	-	-	-	4.5 (1.12)	4.0 (1.00)
910447017	5.5 (1.4)			3.5 (0.87)	0.2 (0.05)	3.5 (0.87)		-	-	-	4.5 (1.12)	4.0 (1.00)	
12:1 Modulating	C (016, 018-31)	300 (88)	910446009	6	5 (1.2)	3.5 (0.87)	0.2 (0.05)	3.5 (0.87)	1.1 (0.27)	-	-	4.5 (1.12)	4.0 (1.00)
			910446010		5 (1.2)	3.5 (0.87)	0.2 (0.05)	3.5 (0.87)	1.1 (0.27)	-	-	4.5 (1.12)	4.0 (1.00)
		450 (130)	910446109		5 (1.2)	3.5 (0.87)	0.2 (0.05)	3.5 (0.87)	1.1 (0.27)	-	-	4.5 (1.12)	4.0 (1.00)
			910446110		5 (1.2)	3.5 (0.87)	0.2 (0.05)	3.5 (0.87)	1.1 (0.27)	-	-	4.5 (1.12)	4.0 (1.00)
		600 (180)	910446209		5 (1.2)	3.5 (0.87)	0.2 (0.05)	3.5 (0.87)	1.1 (0.27)	-	-	4.5 (1.12)	4.0 (1.00)
			910446210		5 (1.2)	3.5 (0.87)	0.2 (0.05)	3.5 (0.87)	1.1 (0.27)	-	-	4.5 (1.12)	4.0 (1.00)

Table 22: Gas Heating Pressures (Propane Gas)

Propane Gas														
				Data shown as inches WC (kPa)										
Control	Cabinet	Furnace Size: MBH (kW)	Furnace PN	Figure (page 61)	P-I	P-M, High	P-M, Low	P-S1, High	P-S1, Low	P-S2, High	P-S2, Low	P-V, Max	P-V, Min	
2 Stage	A (03-06)	80 (23)	910425003	1	11 (2.7)	-	-	10 (2.5)	3 (0.75)	-	-	11.5 (2.86)	11 (2.74)	
		120 (35)	910450403		11 (2.7)	-	-	10 (2.5)	3 (0.75)	-	-	11.5 (2.86)	11 (2.74)	
		160 (47)	910450503		11 (2.7)	-	-	10 (2.5)	3 (0.75)	-	-	11.5 (2.86)	11 (2.74)	
	B (07-015, 17)	200 (59)	910446802		11 (2.7)	-	-	10.5 (2.6)	3 (0.75)	-	-	11.5 (2.86)	11 (2.74)	
		300 (88)	910446902		11 (2.7)	-	-	10.5 (2.6)	3 (0.75)	-	-	11.5 (2.86)	11 (2.74)	
			910446908		11 (2.7)	-	-	10.5 (2.6)	3 (0.75)	-	-	11.5 (2.86)	11 (2.74)	
		400 (120)	910447002		11 (2.7)	-	-	10.5 (2.6)	3 (0.75)	-	-	11.5 (2.86)	11 (2.74)	
			910447008		11 (2.7)	-	-	10.5 (2.6)	3 (0.75)	-	-	11.5 (2.86)	11 (2.74)	
			910447014		11 (2.7)	-	-	10.5 (2.6)	3 (0.75)	-	-	11.5 (2.86)	11 (2.74)	
		C (016, 018-31)	300 (88)		910446003	11 (2.7)	-	-	10 (2.5)	3 (0.75)	-	-	11.5 (2.86)	11 (2.74)
					910446004	11 (2.7)	-	-	10 (2.5)	3 (0.75)	-	-	11.5 (2.86)	11 (2.74)
	450 (130)		910446103		11 (2.7)	-	-	10 (2.5)	-	10 (2.5)	-	11.5 (2.86)	11 (2.74)	
			910446104		11 (2.7)	-	-	10 (2.5)	-	10 (2.5)	-	11.5 (2.86)	11 (2.74)	
	600 (180)		910446203		11 (2.7)	-	-	10 (2.5)	-	10 (2.5)	-	11.5 (2.86)	11 (2.74)	
			910446204		11 (2.7)	-	-	10 (2.5)	-	10 (2.5)	-	11.5 (2.86)	11 (2.74)	
4 Stage	300 (88)	910446007	11 (2.7)	-	-	10 (2.5)	3 (0.75)	10 (2.5)	3 (0.75)	11.5 (2.86)	11 (2.74)			
		910446008	11 (2.7)	-	-	10 (2.5)	3 (0.75)	10 (2.5)	3 (0.75)	11.5 (2.86)	11 (2.74)			
	450 (130)	910446107	11 (2.7)	-	-	10 (2.5)	3 (0.75)	10 (2.5)	3 (0.75)	11.5 (2.86)	11 (2.74)			
		910446108	11 (2.7)	-	-	10 (2.5)	3 (0.75)	10 (2.5)	3 (0.75)	11.5 (2.86)	11 (2.74)			
	600 (180)	910446207	11 (2.7)	-	-	10 (2.5)	3 (0.75)	10 (2.5)	3 (0.75)	11.5 (2.86)	11 (2.74)			
		910446208	11 (2.7)	-	-	10 (2.5)	3 (0.75)	10 (2.5)	3 (0.75)	11.5 (2.86)	11 (2.74)			

(continued)														
Propane Gas														
				Data shown as inches WC (kPa)										
Control	Cabinet	Furnace Size: MBH (kW)	Furnace PN	Figure (page 61)	P-I	P-M, High	P-M, Low	P-S1, High	P-S1, Low	P-S2, High	P-S2, Low	P-V, Max	P-V, Min	
5:1 Modulating	A (03-06)	80 (23)	910425004	4	11 (2.7)	10 (2.5)	0.6 (0.15)	-	-	-	-	11.5 (2.86)	11 (2.74)	
		120 (35)	910450404		11 (2.7)	10 (2.5)	0.6 (0.15)	-	-	-	-	11.5 (2.86)	11 (2.74)	
		160 (47)	910450504		11 (2.7)	10 (2.5)	0.6 (0.15)	-	-	-	-	11.5 (2.86)	11 (2.74)	
	B (07-015, 17)	200 (59)	910446804		11 (2.7)	10.5 (2.6)	0.6 (0.15)	-	-	-	-	11.5 (2.86)	11 (2.74)	
		300 (88)	910446904		11 (2.7)	10.5 (2.6)	0.6 (0.15)	-	-	-	-	11.5 (2.86)	11 (2.74)	
			910446910		11 (2.7)	10.5 (2.6)	0.6 (0.15)	-	-	-	-	11.5 (2.86)	11 (2.74)	
		400 (120)	910447004		11 (2.7)	10.5 (2.6)	0.6 (0.15)	-	-	-	-	11.5 (2.86)	11 (2.74)	
			910447010		11 (2.7)	10.5 (2.6)	0.6 (0.15)	-	-	-	-	11.5 (2.86)	11 (2.74)	
			910447016		11 (2.7)	10.5 (2.6)	0.6 (0.15)	-	-	-	-	11.5 (2.86)	11 (2.74)	
10:1 Modulating	200 (59)	910446806	5	11 (2.7)	10.5 (2.6)	0.6 (0.15)	10.5 (2.6)	-	-	-	-	11.5 (2.86)	11 (2.74)	
		300 (88)		910446906	11 (2.7)	10.5 (2.6)	0.6 (0.15)	10.5 (2.6)	-	-	-	-	11.5 (2.86)	11 (2.74)
				910446973	11 (2.7)	10.5 (2.6)	0.6 (0.15)	10.5 (2.6)	-	-	-	-	11.5 (2.86)	11 (2.74)
	400 (120)	910447006		11 (2.7)	10.5 (2.6)	0.6 (0.15)	10.5 (2.6)	-	-	-	-	11.5 (2.86)	11 (2.74)	
		910447012		11 (2.7)	10.5 (2.6)	0.6 (0.15)	10.5 (2.6)	-	-	-	-	11.5 (2.86)	11 (2.74)	
		910447018		11 (2.7)	10.5 (2.6)	0.6 (0.15)	10.5 (2.6)	-	-	-	-	11.5 (2.86)	11 (2.74)	
12:1 Modulating	300 (88)	910446011	6	11 (2.7)	10 (2.5)	0.8 (0.2)	10 (2.5)	3 (0.75)	-	-	-	11.5 (2.86)	11 (2.74)	
		910446012		11 (2.7)	10 (2.5)	0.8 (0.2)	10 (2.5)	3 (0.75)	-	-	-	11.5 (2.86)	11 (2.74)	
	450 (130)	910446111		11 (2.7)	10 (2.5)	0.8 (0.2)	10 (2.5)	3 (0.75)	-	-	-	11.5 (2.86)	11 (2.74)	
		910446112		11 (2.7)	10 (2.5)	0.8 (0.2)	10 (2.5)	3 (0.75)	-	-	-	11.5 (2.86)	11 (2.74)	
	600 (180)	910446211		11 (2.7)	10 (2.5)	0.8 (0.2)	10 (2.5)	3 (0.75)	-	-	-	11.5 (2.86)	11 (2.74)	
		910446212		11 (2.7)	10 (2.5)	0.8 (0.2)	10 (2.5)	3 (0.75)	-	-	-	11.5 (2.86)	11 (2.74)	

Burner and Gas Manifold Pressure Adjustment Instructions

For correct gas pressures referenced in these instructions, refer to [Table 21 on page 64](#) (Natural Gas) and [Table 22 on page 66](#) (Propane). For definition of pressure measurement locations, refer to [Figure 72 on page 61](#). For identification of valve components, refer to the figures beginning on [page 62](#).

2-Stage Furnaces

1. Read gas pressure at the Inlet Pressure Tap of the staged valve(s) and confirm pressure matches the value specified for your unit's capacity and modulation configuration. Adjust upstream pressure reducing gas regulator as required to obtain inlet pressure specified.
2. In main cabinet control panel, set Microtech 4 controller to manual mode. Specify high fire operation by setting "Htg Stage 2" menu item to ON. Back at the furnace, read gas pressure(s) on the burner manifold pressure tap. Confirm pressure matches the HIGH value specified for your unit's capacity and modulation configuration. If adjustment is required, adjust the HI regulator on the staged gas valve(s).
3. Only follow this step if your furnace uses a 2-stage gas valve. In main cabinet control panel, set MicroTech 4 controller to manual mode. If "Htg Stage 2" menu item is set to ON, turn it OFF. Specify low fire operation by setting "Htg Stage 1" menu item to ON. Back at the furnace, read gas pressure on the burner manifold pressure tap. Confirm pressure matches the LOW value specified for your unit's capacity and modulation configuration. If adjustment is required, adjust the Lo/Med regulator on the two stage gas valve.

4-Stage Furnaces

1. Read gas pressure at the Inlet Pressure Tap of the two stage valves and confirm pressure matches the value specified for your unit's capacity and modulation configuration. Adjust upstream pressure reducing gas regulator as required to obtain inlet pressure specified.
2. In main cabinet control panel, set MicroTech 4 controller to manual mode. Specify high fire operation by setting all "Htg Stage" menu items to ON. Back at the furnace, read gas pressures on the burner manifold pressure taps. Confirm both pressures match the HIGH value specified for your unit's capacity and modulation configuration. If adjustment is required, adjust the HI regulator on the relevant two stage gas valve.
3. In main cabinet control panel, set MicroTech 4 controller to manual mode. If any "Htg Stage" menu items are ON, turn them OFF. Specify low fire operation by turning "Htg Stage 1" ON. Back at the furnace, read gas pressures on the burner manifold pressure taps. Confirm both pressures match the LOW value specified for your unit's capacity and modulation configuration. If adjustment is required, adjust the Lo/Med regulator on the relevant two stage gas valve.

Modulating Furnaces

1. Read gas pressure at the Inlet Pressure Tap of the staged valve(s) and confirm pressure matches the value specified for your unit's capacity and modulation configuration. Adjust upstream pressure reducing gas regulator as required to obtain inlet pressure specified.
2. In main cabinet control panel, set MicroTech 4 controller to manual mode. Specify high fire operation by "Htg Valve" menu item to 100%. Continue to specify high fire operation by setting all available "Htg Stage" menu items to ON. Back at the furnace, read the gas pressures specified for your configuration on the burner manifold pressure taps. Confirm each pressure matches the HIGH value specified for each manifold for your unit's capacity and modulation configuration. If adjustment is required, adjust the HI regulator on the relevant staged gas valve. If the correct modulating manifold pressure cannot be achieved by adjusting the upstream staged safety valve, refer to ["Maxitrol EXA Star Controller" on page 69](#).
3. In main cabinet control panel, set MicroTech 4 controller to manual mode. Specify low fire operation by setting all available "Htg Stage" menu items to OFF. Continue to set low fire operation by setting the "Htg Valve" menu item to the applicable value shown in [Table 23](#).
4. At the furnace, read gas pressure on the burner manifold pressure tap. Confirm pressure matches the LOW value specified for your unit's capacity and modulation configuration. If adjustment is required, refer to ["Maxitrol EXA Star Controller" on page 69](#).

Table 23: Modulating Furnace Low Fire "Htg Valve" Value

Cabinet Size	Furnace Size	Furnace Turndown	Modulating Section Size (% of furnace size)	Low Fire "Htg Valve" Setting
A	80, 120, 160	5:1	100%	20%
B	200, 300, 400	5:1	100%	20%
		10:1	50%	20%
C	300, 450, 600	12:1	33%	25%

Maxitrol EXA Star Controller

WARNING

All adjustments should be made by a qualified service agency in accordance with the manufacturer's instructions and all applicable codes and requirements of the authority having jurisdiction. If the information in these instructions is not followed exactly, a fire, explosion or production of carbon monoxide may result causing property damage, personal injury, or loss of life. The qualified service agency performing this work assumes the responsibility for the proper adjustment of the appliance.

WARNING

Adjusting the Modulating valve beyond its physical limits may result in permanent damage to the valve and production of Carbon Monoxide during modulation. Serious personal injury and death can result if not adjusted correctly.

NOTICE

These instructions are intended for the adjustment and troubleshooting of the Maxitrol EXA (E40H and E50H) modulating gas valves used with the Beckett VB1285 modulating control. Always set manifold pressures to the value on the appliance's rating plate.

Pre-Adjustment Verification

Prior to adjusting gas pressure, ensure the following items are checked and verified:

1. Check VB1285 ignition control for any error codes.
 - a. If error codes are present, unit performance may be affected. Clear error codes from the control by powering off for 10 seconds.
2. Verify inlet pressure to the safety valve is within the correct range per the appliance rating plate and adjust if necessary.
3. Verify gas pressure at the outlet of the safety valve is between:
 - 4.5 and 5.0" WC if NG
 - 11.0 11.5" WC if LP
 - If gas pressure is outside of the designated ranges, correct and check manifold pressure.
4. Remove modulating valve cover and verify that the modulating valve is wired correctly according to the following wire colors and description:
 - 24VAC (+) (Blue)
 - 24VAC (-) (Yellow)
 - 10VDC (+) (Red)
 - 10VDC (-) (White)
 - Ensure purple com wire is connected correctly, as shown in [Figure 79 on page 70](#)
 - Correct any wiring that is incorrect per the wiring diagram.
5. Verify that dip switches on the modulating valve are set correctly.
 - Switch 1 (OFF)
 - Switch 2 (ON)
 - Switch 3 (OFF)

Primary Manifold Pressure Adjustment

1. Using the MicroTech unit controller's "Manual Control" menu, set the heating output to 100%.

NOTE: Ensure all required dampers are opened and adequate airflow is provided across the heating section in manual control prior to sending heat demand to the heating section.

2. If modulating manifold pressure is between 3.0 and 3.5" WC, adjust by increasing safety valve pressure.
 - a. Remove the brass regulator screw on the safety valve.
 - b. Increase safety valve pressure by turning the plastic screw clockwise until the desired manifold pressure is achieved.
 - c. Replace the brass screw cover.

Modulating Valve Setting Adjustment

WARNING

Adjusting the modulating valve beyond its physical limits may result in permanent damage to the valve and production of carbon monoxide (CO) during modulation. Serious personal injury and death can result if not adjusted correctly.

Use calibration procedure defined in "[Maxitrol EXA Star Valve Over-Traveled State Calibration](#)" on [page 98](#) if modulating valve is believed to be in a mechanically over-traveled state.

If safety valve pressure is between 4.5 and 5.0" WC and modulating manifold pressure is below 3.0" WC Modulating valve settings may need to be adjusted. Perform the following procedure to adjust the modulating valve:

1. Remove the blue cover on the modulating valve.
2. For high input adjustment, press and hold button #1 until the red LED light comes on. Refer to [Figure 79 on page 70](#).
3. Once the red light is on, toggle between buttons #1 and #2 to adjust the manifold pressure.
 - Button #1 increases gas flow
 - Button #2 decreases gas flow
 - Each press of a button will move the set point of the valve up or down by one step. It is best to adjust with discrete clicks of the button so as not to drive the valve beyond its physical limits.
4. Press and hold both buttons simultaneously to set valve. Red light will turn off.
5. For low input adjustment, use the MicroTech unit controller's "Manual Control" menu to set the heating output to 25% or when the MicroTech unit controller outputs 2 VDC from the analog output.
6. Press and hold button #2 until the red LED starts flashing. Refer to [Figure 79 on page 70](#).
7. Once the LED starts flashing, toggle between button #1 and button #2 to adjust the manifold pressure.
 - Button #1 increases gas flow
 - Button #2 decreases gas flow

- Each press of a button will move the set point of the valve up or down by one step. It is best to adjust with discrete clicks of the button so as not to drive the valve beyond its physical limits.
- 8. Press and hold both buttons simultaneously to set value.
- 9. Verify manifold pressure at high input did not change by sending a high input signal to the VB1285.
- If the high input setpoint changed, return to Step 2 for high input adjustment and verify manifold pressure did not change.
- 10. Verify manifold pressure at low input did not change by sending a low input signal to the VB1285.
- 11. Once manifold pressure has been verified, replace the modulating Valve cover.

Figure 77: Example Gas Curves: Single Stage Modulating Furnace

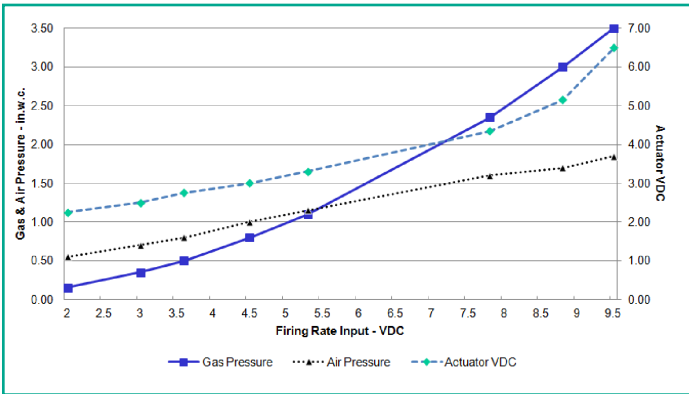
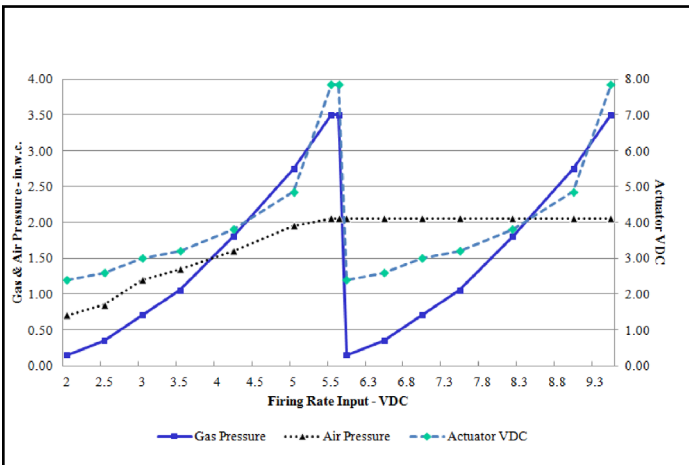
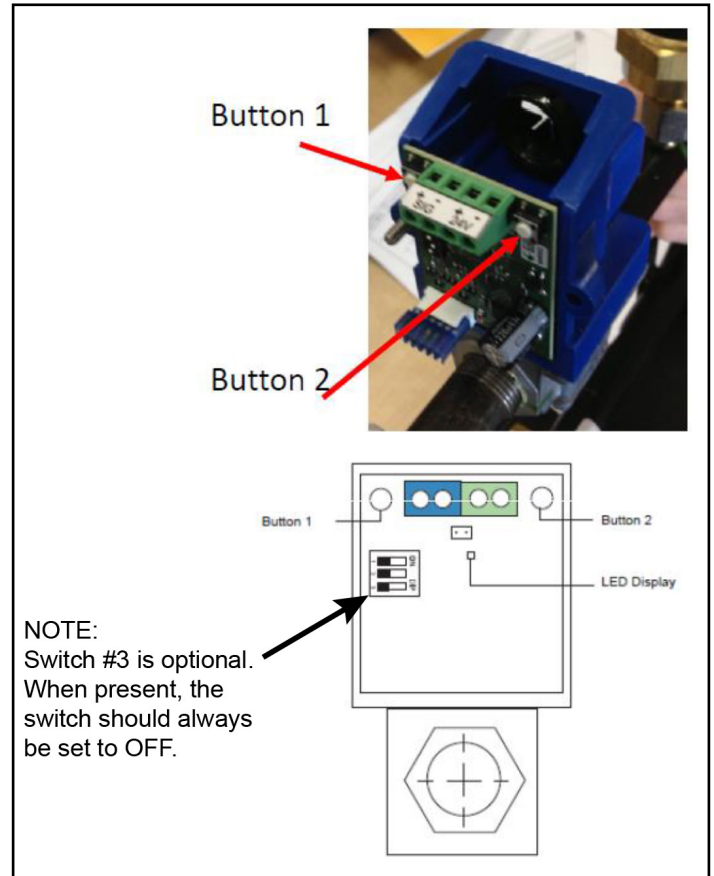

Figure 78: Example Gas Curves: Multi-Stage Modulating Furnace



NOTE: Example graphs shown are provided to illustrate the general shape of the gas curves and should not be used for troubleshooting. Minimum and maximum manifold pressures can be found in Table 21 and Table 22. If further details are required, contact Daikin Applied Service.

Figure 79: Maxitrol EXA Star LEDs



Sequences of Operation

The following sequences of operation apply to individual control boards and the furnace sections they control (see figures beginning on page 57). In units with multiple control boards, the Microtech controller will send a signal to the VB1285 board, which will subsequently signal the VB1287 board to operate when it is needed (see tables beginning on page 72 for a summary of the engaged furnace sections).

VB1285 BPP Modulating Control - Standard and Split Manifolds

1. A call for heat is initiated by the rooftop unit control through a digital Modbus signal. Refrigeration-only control packages may differ.
2. The VB1285 control will then go through a system check to ensure that the high temperature limit and rollout switches are closed, the air pressure switch is open, and the modulating valve is positioned correctly.
3. The control will then enter the pre-purge cycle, where the inducer will run at the programmed purge pressure. During this cycle, the control will look for the air pressure switch to close and open at the correct settings.
4. Once the system check and pre-purge cycles are complete, the control will enter the ignition cycle.

- a. The modulating valve and inducer will go to their "light off" settings.
 - b. The DSI ignition module will be energized and the spark ignitor will activate.
 - c. The redundant safety valve will open, allowing gas flow.
 - d. The burners will ignite and the control will receive a signal from the flame sensor.
 - e. The spark ignitor will remain active for the duration of the ignition cycle, regardless of flame status.
5. If flame is not established during the ignition cycle, the control will repeat the pre-purge and ignitions cycles up to three times. After three failed ignition attempts, the board will enter a 1 hour lockout.
 6. Once flame has been established, the control will enter a warmup period to ensure flame stabilization and reduce condensation in the heat exchanger.
 7. After the warmup period, the control will enter the run cycle. During the run cycle, the burner firing rate and draft inducer pressure are determined based on the heat demand received by the control via a Modbus signal.

NOTE: If the control is paired with a split manifold, steps 1 through 6 pertain to the primary burners. Once the control exits the warmup period and the firing rate is dictated by the rooftop control, the control will modulate the primary burners and ignite the secondary burners based on the demand for heat.

8. The run cycle will continue until any of the following conditions are met:
 - a. The call for heat is terminated.
 - b. Any of the safety devices (high limit, air pressure, rollout, etc.) are triggered.
 - c. The control reaches its maximum run time of 6 hours. If this condition is reached, the control will terminate the run cycle, continue through the proper sequence of operations, and then immediately enter the system check and pre-purge cycles to prepare for reignition.
9. Once the run cycle has terminated, the redundant safety valve will close, the modulating valve will return to its set position, and the draft inducer will ramp up to its "light-off" setting for a 45 second post-purge cycle.
10. After the conclusion of the post-purge, the control will enter the "OFF" state. While safety devices are still monitored, all system outputs are de-energized.

VB1287 BPP Staged Control - Standard and Split Manifolds

1. A call for heat is initiated by the rooftop unit control through a digital Modbus signal. Refrigeration-only control packages may differ.
2. The VB1287 control will then go through a system check to ensure that the high temperature limit and rollout switches are closed, the air pressure switch is open, and the modulating valve is positioned correctly.

3. The staged control will then enter the pre-purge cycle, where the inducer will run at the programmed purge pressure. During this cycle, the control will look for the air pressure switch to close and open at the correct settings.
4. Once the system check and pre-purge cycles are complete, the control will enter the ignition cycle.
 - a. The inducer will go to its "light off" setting (usually high speed).
 - b. The DSI ignition module will be energized and the spark ignitor will activate.
 - c. The control valve and any redundant safety valves will open, allowing gas flow.
 - d. The burners will ignite and the VB1287 control will receive a signal from the flame sensor.
 - e. The spark ignitor will remain active for the duration of the ignition cycle, regardless of flame status.
5. If flame is not established during the ignition cycle, the control will repeat the pre-purge and ignition cycles up to three times. After three failed ignition attempts, the board will enter a 1 hour lockout.
6. Once flame has been established, the control will enter a warmup period to ensure flame stabilization and reduce condensation in the heat exchanger.
7. After the warmup period, the control will enter the run cycle. If equipped with a 2-stage valve, during the run cycle the burner firing rate is determined by the heat demand received by the control via a Modbus signal. Two firing stages, High or Low, are available.

NOTE: If the control is paired with a split manifold, steps 1 through 6 pertain to the primary burners. Once the control exits the warmup period and the firing rate is dictated by the rooftop control, the control will step the primary burners High or Low (if equipped with a 2-stage valve) and ignite the secondary burners based on the demand for heat.

8. The run cycle will continue until any of the following conditions are met:
 - a. The call for heat is terminated.
 - b. Any of the safety devices (high limit, air pressure, rollout, etc.) are triggered.
 - c. The control reaches its maximum run time of 6 hours. If this condition is reached, the control will terminate the run cycle, continue through the proper sequence of operations, and then immediately enter the system check and pre-purge cycles to prepare for reignition.
9. Once the run cycle has terminated, any redundant safety valves present will close, the staged control valve will close, and the draft inducer will ramp up to its "light-off" setting for a 45 second post-purge cycle.
10. After the conclusion of the post-purge, the control will enter the "OFF" state. All system outputs are de-energized but all safety devices are still monitored.

Refrigeration Only Controls (ROC)

When the unit is equipped with Refrigeration Only Controls (ROC), the field-provided controller must send a 0-10V signal to the MicroTech controller. Refer to the as-built wiring diagrams provided with your unit for specific configurations and control signal landing locations. The diagrams beginning on [page 57](#) may be used as a general reference.

NOTE: The MicroTech unit controller will only operate the furnace if airflow is also called for. In addition, the controller will delay fan shut-off until the furnace has been turned off for a predetermined time.

Table 24: ROC Staging Information

Modulating	Input Voltage Signal (VDC)	Modulating Section M	Staged Section S1	Approximate Furnace Output (% of Maximum)
Modulating - 5:1	0.00 - 0.20	Off	-	0
	0.20 - 2.00	20%	-	20%
	2.00 - 10.00	20% - 100%	-	20% - 100%
	10.00+	100%	-	100%
Modulating - 10:1	0.00 - 0.20	Off	Off	0
	0.20 - 2.00	20%	Off	10%
	2.00 - 10.00	20% - 100%	On @ ~6V	10% - 100%
	10.00+	100%	High	100%
Modulating - 12:1	0.00 - 0.20	Off	Off	0
	0.20 - 2.00	25%	Off	8.3%
	2.00 - 10.00	25% - 100%	Low @ ~4.7V High @ ~7.3V	8.3% - 100%
	10.00+	100%	High	100%
Staged	Input Voltage Signal (VDC)	Staged Section S1	Staged Section S2	Approximate Furnace Output (% of Maximum)
Standard Manifold - 2-Stage	0 - 0.20	Off	-	0%
	0.2 - 9.50	Low	-	50%
	9.50+	High	-	100%
Split Manifold - 2-Stage	0 - 0.20	Off	Off	0%
	0.2 - 9.50	On	Off	50%
	9.50+	On	On	100%
4-Stage	0 - 0.20	Off	Off	0%
	0.20 - 5.00	Low	Off	25.0%
	5.00 - 7.50	Low	Low	50%
	7.50 - 9.50	High	Low	75.0%
	9.50+	High	High	100%

NOTE: "Modulating Section" refers to only section M if standard sections are used, but sections M and S1 if split sections are used. Refer to the diagrams beginning on [page 61](#) for section location and identification.

Fuel and Altitude Conversions

⚠ DANGER

Never test for gas leaks with an open flame. It can cause an explosion or fire resulting in property damage, personal injury, or death. Use a commercially available soap solution made specifically for the detection of leaks to check all connections.

Altitude Conversion

For elevations up to 2,000 feet, rating plate input ratings apply. For high altitudes (elevations over 2,000 ft.), contact Daikin Applied Parts. See [Table 25](#) for part numbers.

NOTE: If the fuel source has been derated for altitude by the local utility provider then a conversion kit is not required.

Table 25: Altitude Conversion Kit Identification

Fuel	Cabinet	Elevation	Part Number
Natural Gas	A	2000-2999	404231250
		3000-3999	404231251
		4000-5999	404231252
		6000-7999	404231253
		8000-8999	404231254
		9000-9999	404231255
		≥10000	404231256
		B	2000-2999
	3000-6999		404225364
	7000-8999		404225365
	9000-9999		404225366
	≥10000		404225367
	C	2000-2999	404225363
		3000-6999	404225364
		7000-8999	404225365
		9000-9999	404225366
		≥10000	404225367
	LP Gas	A	2000-3999
4000-5999			404231246
6000-6999			404231247
7000-8999			404231248
≥9000			404231249
B		2000-2999	404225358
		3000-5999	404225359
		6000-7999	404225360
		8000-9999	404225361
		≥10000	404225362
C		2000-2999	404225358
		3000-5999	404225359
		6000-7999	404225360
		8000-9999	404225361
		≥10000	404225362

Fuel Conversion

⚠ WARNING

This unit is equipped at the factory for use with either natural gas (NG) or liquefied propane (LP). Conversion to another of the offered gases requires a special kit supplied by Daikin Applied Parts. Refer to [Table 26](#) for kit part numbers. Failure to use the proper conversion kit can cause fire, carbon monoxide poisoning, explosion, personal injury, property damage, or death.

Convert the furnace in this unit using the gas valve spring and burner nozzles supplied in the conversion kit.

The gas valve maintains the proper manifold pressure for the converted gas. The correct burner orifices are included in the kit.

Table 26: Furnace Identification for Fuel Conversion

Kit Type	Cabinet Size	Furnace Size (MBH)	Furnace Turndown	Daikin Applied P/N
Convert NG to LP	A	80	5:1 Mod.	910527701
		120		910527702
		160		910527703
		ANY	Staged	910527704
	B	200	5:1 Mod.	910527705
			10:1 Mod.	910527706
		300	5:1 Mod.	910527707
			10:1 Mod.	910527708
		400	5:1 Mod.	910527709
			10:1 Mod.	910527710
	ANY	Staged	910527711	
	C	300	12:1 Mod.	910527712
				910527713
				910527714
		600	2-Stage	910527715
				910527716
		450, 600	2-Stage	910527716
		ANY	4-Stage	910527717
Convert LP to NG	A	80	5:1 Mod.	910527718
		120		910527719
		160		910527720
		ANY	Staged	910527721
	B	200	5:1 Mod.	910527722
			10:1 Mod.	910527723
		300	5:1 Mod.	910527724
			10:1 Mod.	910527725
		400	5:1 Mod.	910527726
			10:1 Mod.	910527727
	ANY	Staged	910527728	
	C	300	12:1 Mod.	910527729
				910527730
				910527731
		600	2-Stage	910527732
				910527733
		450, 600	2-Stage	910527733
	ANY	4-Stage	910527734	

Start-Up Procedures

Start-Up Responsibility



Overheating or failure of the gas supply to shut off can cause equipment damage, severe personal injury, or death.

Turn off the manual gas valve to the appliance before shutting off the electrical supply.

The start-up organization is responsible for determining that the furnace, as installed and as applied, will operate within the limits specified on the furnace rating plate.

1. The furnace must not operate at insufficient airflow or temperature rise greater than specified (refer the tables beginning on [page 53](#)). On variable air volume systems it must be determined that the furnace will not be operated if or when system cfm is reduced below the specified minimum airflow cfm.
2. It must be established that the gas supply is within the proper pressure range (refer to [Table 16 on page 53](#)).

Start-up and service of this equipment must be performed by trained and experienced technicians. It is highly recommended that the initial start-up and future service be performed by Daikin Applied trained technicians who are familiar with working on live equipment. A representative of the owner or the operator of the equipment should be present during start-up to receive instructions in the operation, care and adjustment of the unit.

Before Start-Up

1. Notify inspectors or representatives who may be required to be present during start-up of gas fuel equipment. These could include the gas utility company, city gas inspectors, heating inspectors, etc.
2. Review the equipment and service literature and become familiar with the location and purpose of the furnace controls. Determine where the gas and power can be turned off at the unit and before the unit.
3. Determine that power is connected to the unit and available.
4. Determine that the gas piping, meter, and service regulator have been installed, tested, and meet the equipment requirements.
5. Determine that proper instruments will be available for the start-up. A proper start-up requires the following: voltmeter, manometer or gauges with ranges for both manifold pressure and inlet gas pressure.

Start-Up Preliminary

Close Gas Main

1. Check the burner fan wheel for binding, rubbing, or loose setscrews.
2. Check power.
3. Purge the gas lines.
4. Leak check. Using a rich soap-water mixture and a brush, check the gas lines for leaks. Correct all leaks before starting furnace.

Operating Procedures

Set the controller to the lowest setting.

1. Turn off all electric power to the appliance.
2. This appliance is equipped with an ignition device which automatically lights the burner. Do NOT try to light the pilot by hand.
3. Open the control access panel.
4. Turn the gas control clockwise to "OFF".
5. Wait five (5) minutes to clear out any gas. Then, smell for gas, including near the floor. If you smell gas, **STOP!** Follow step "B" in the DANGER label on this page. If you don't smell gas, proceed to the next step.
6. Turn the gas control counter-clockwise to "ON".
7. Close the control access panel.
8. Turn on all electric power to the appliance.
9. Set controller to full heat.
10. Verify manifold pressure and rate.
11. If the appliance will not operate, refer to "Turning Off Gas to the Appliance", and call a qualified service technician.

Turning OFF Gas to the Appliance

1. Set the controller to the lowest setting.
2. Turn OFF all electrical power to the appliance if service is to be performed.
3. Open the control access panel.
4. Turn gas control knob clockwise to "OFF". Do not force.
5. Close the control access panel.

Service

The furnace DDC controller has diagnostic information for troubleshooting the furnace operation. The ignition control module has a LED light that will flash when an abnormal condition occurs. See "[Gas Furnace Ignition and Control Troubleshooting](#)" on page 96.

Maintenance

Planned maintenance is the best way to avoid unnecessary expense and inconvenience. Have this system inspected at regular intervals by a trained and experienced service technician. The following service intervals are typical for average situations but will have to be adjusted to suit your particular circumstances.

Fuel pressure settings and control settings should be modified only by persons thoroughly experienced with the burner and control system, and must not be tampered with by persons without such experience.

Always replace covers on burner controls and boxes as the electrical contacts are sensitive to dust and dirt. Perform maintenance of controls, gas valves, and other components in accordance with instructions in the manufacturer's bulletins.

Monthly

Check cabinet air filters and replace if dirty.

Twice Yearly

1. **Combustion Air:** Check combustion inducer fan for dirt buildup and lint. Check combustion air intake louvers and flue box/vent for accumulation of dirt and debris.
2. **Cleaning:** Inspect and clean flue tubes and combustion chamber. Keep burner vestibule clean. Dirt and debris can result in poor combustion and lower efficiency.

Yearly

1. **Debris:** Check vent terminal screens for blockages and accumulation.
2. **Heater and the Venting System:** Shall be inspected once a year by a qualified service agency.
3. **Gas Train:** Check all valves, piping and connections for leakage with a rich soap solution or UL 913 combustible gas leak detector. Any bubbling is considered a leak and must be eliminated. Inspect and clean flame rod, ignition electrode, and burner manifold.
4. **Condensate Pan and Drain:** Remove any debris that may have accumulated in the drain pan and drain.

Special Weather Events

1. After heavy snowfall, verify that combustion air intakes are not blocked by snow.
2. Periodically check during periods of snow accumulation as drifting may also lead to combustion air intake blockage.

Figure 80: Rebel A Cabinet (Sizes 03-06) 2-Stage Furnace Wiring Diagram

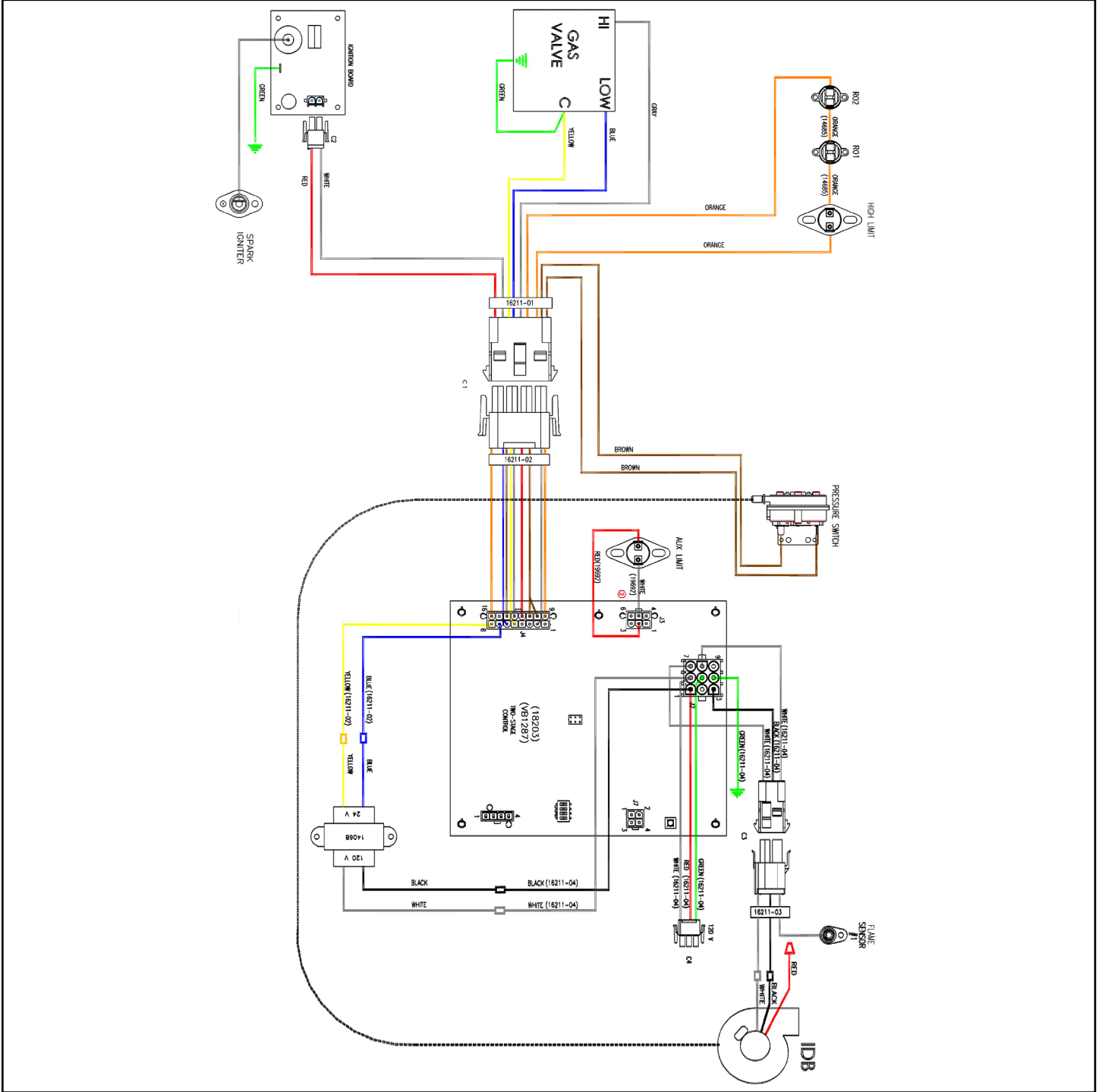

Figure 81: Rebel A Cabinet (Sizes 03-06) 2-Stage Furnace Electrical Schematic and Pinout Detail

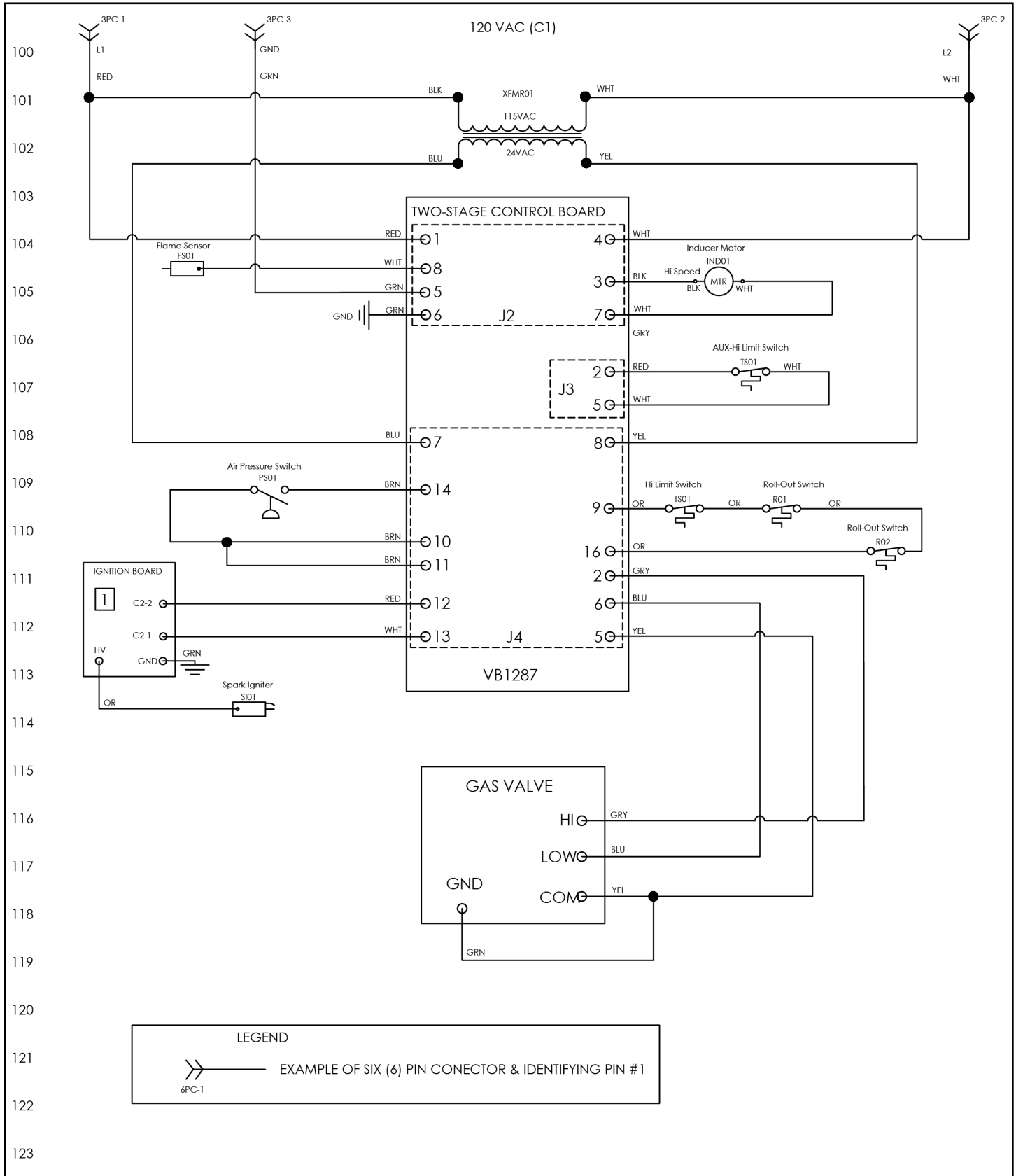

Figure 82: Rebel B Cabinet (Sizes 03-06) Modulating Furnace Wiring Diagram

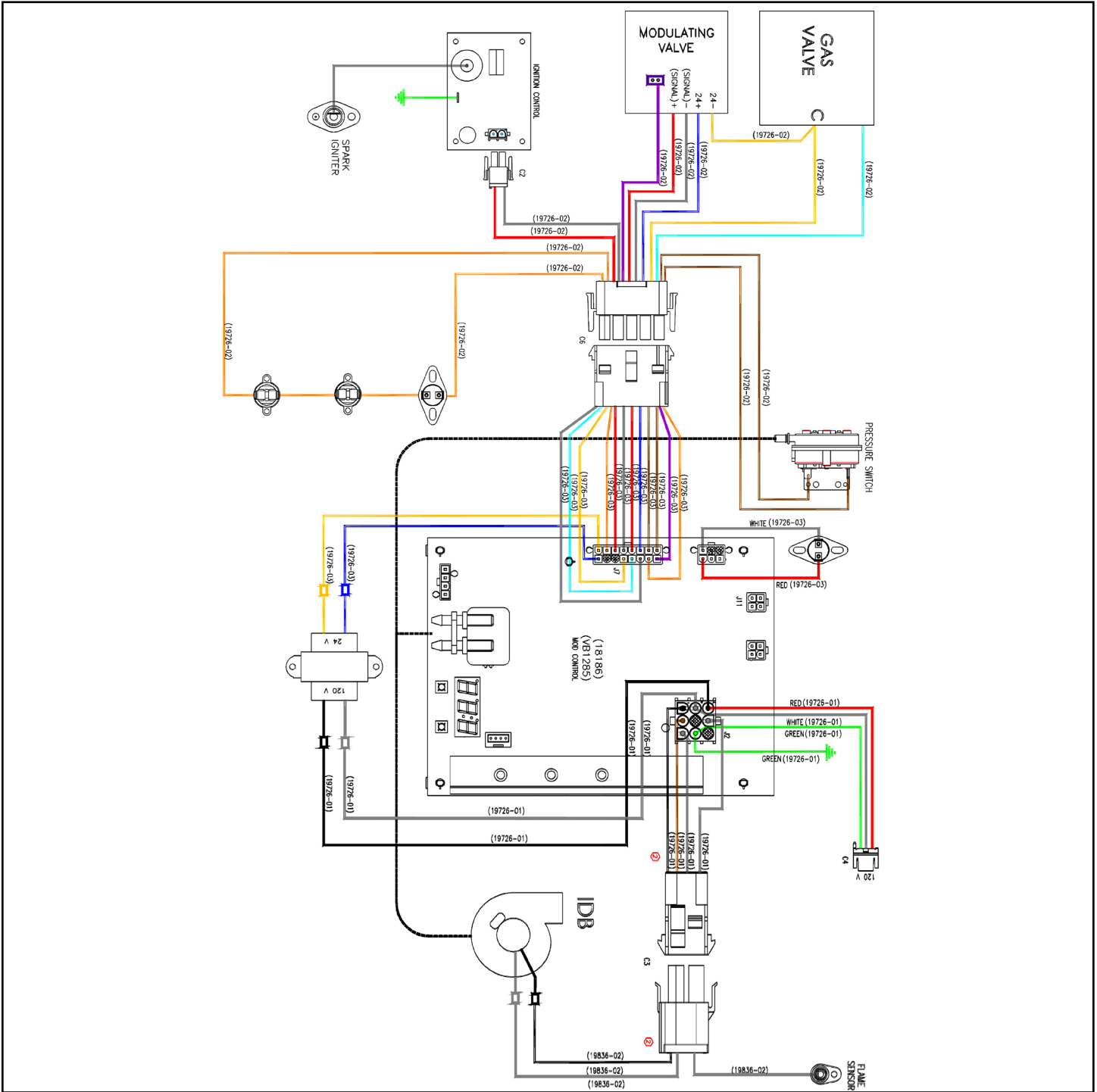

Figure 83: Rebel B Cabinet (Sizes 03-06) Modulating Furnace Electrical Schematic and Pinout Detail

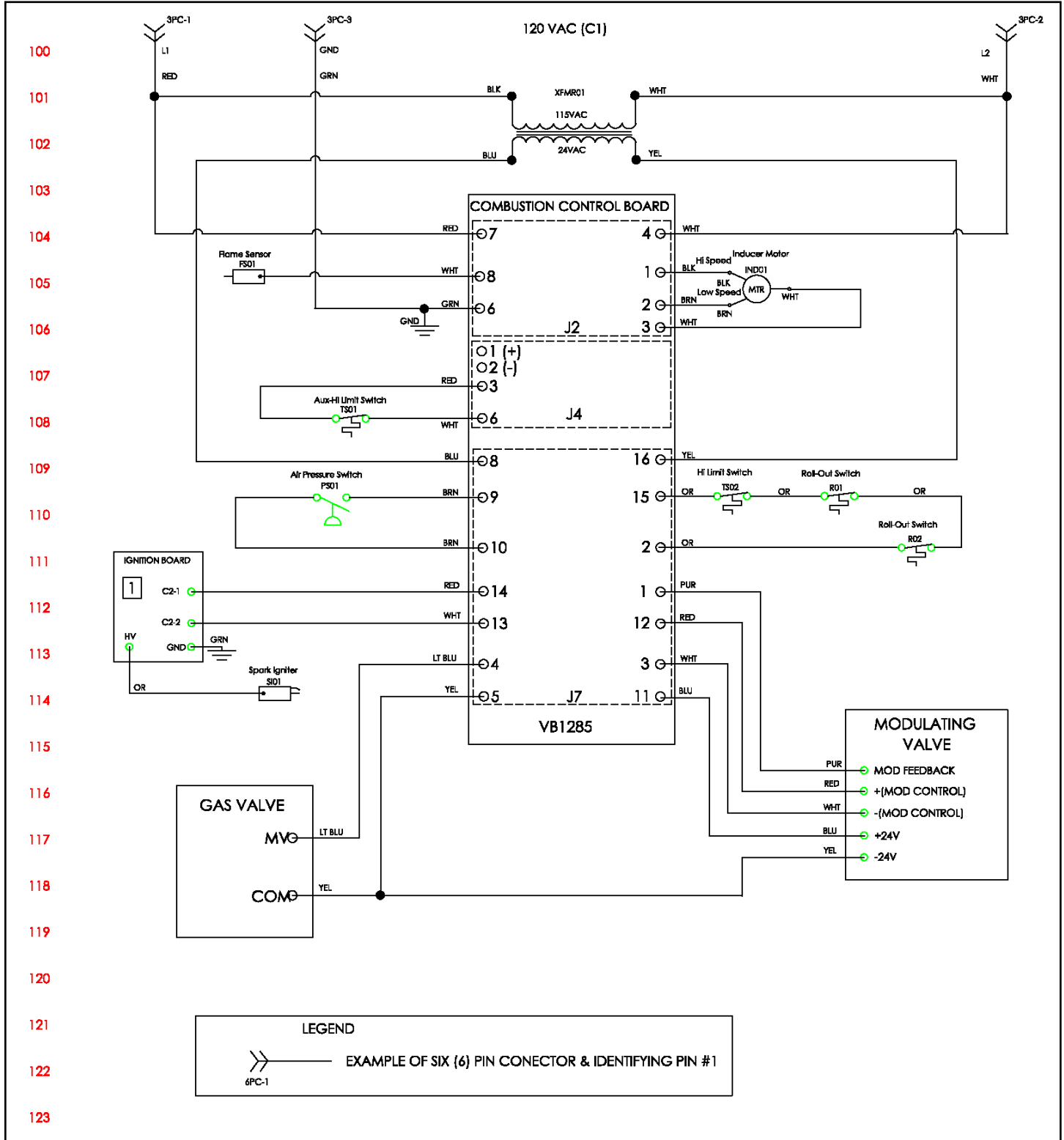

Figure 84: Rebel B Cabinet (Sizes 07-17) 2-Stage Furnace Wiring Diagram

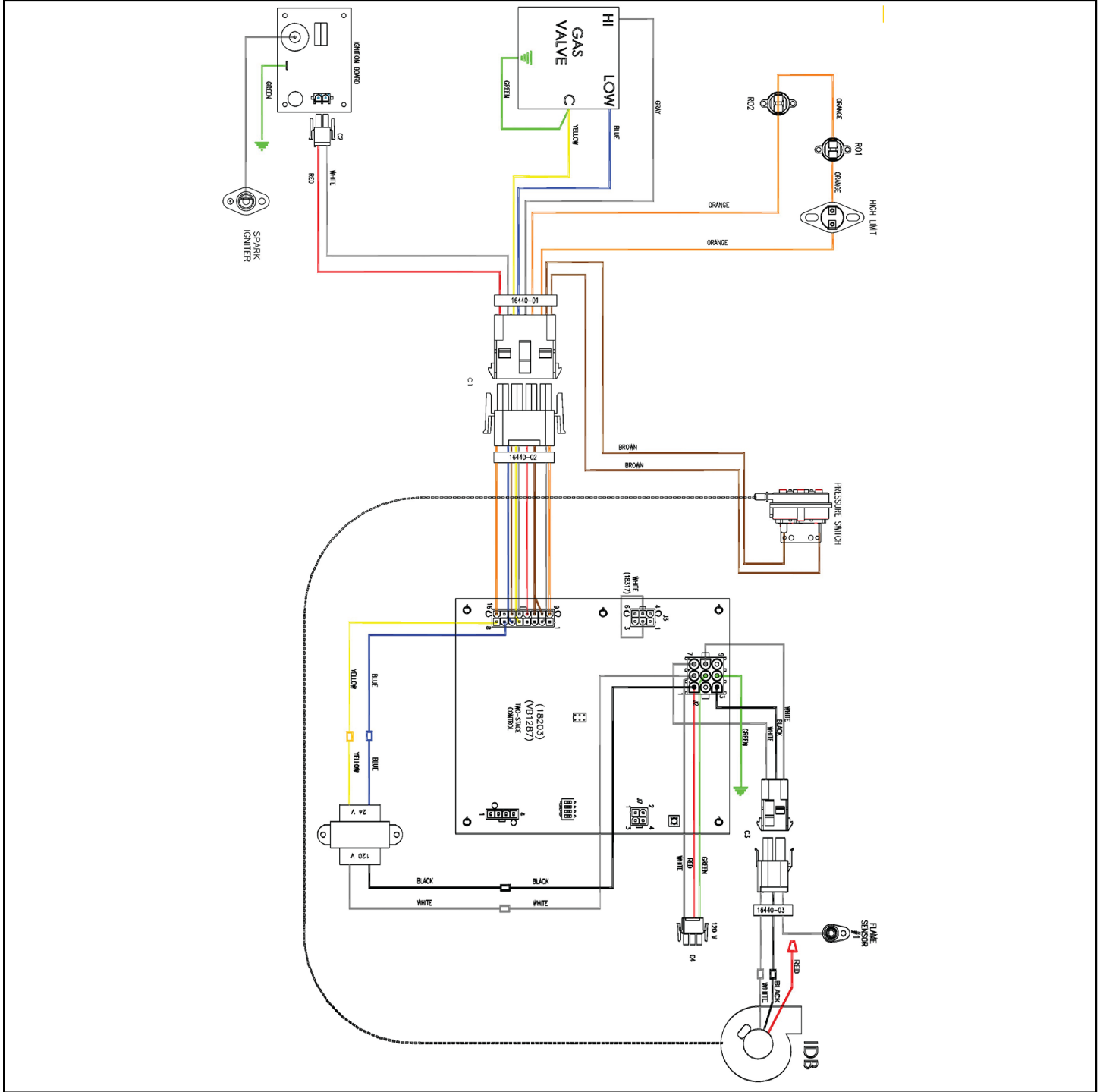

Figure 85: Rebel B Cabinet (Sizes 07-17) 2-Stage Furnace Electrical Schematic and Pinout Detail

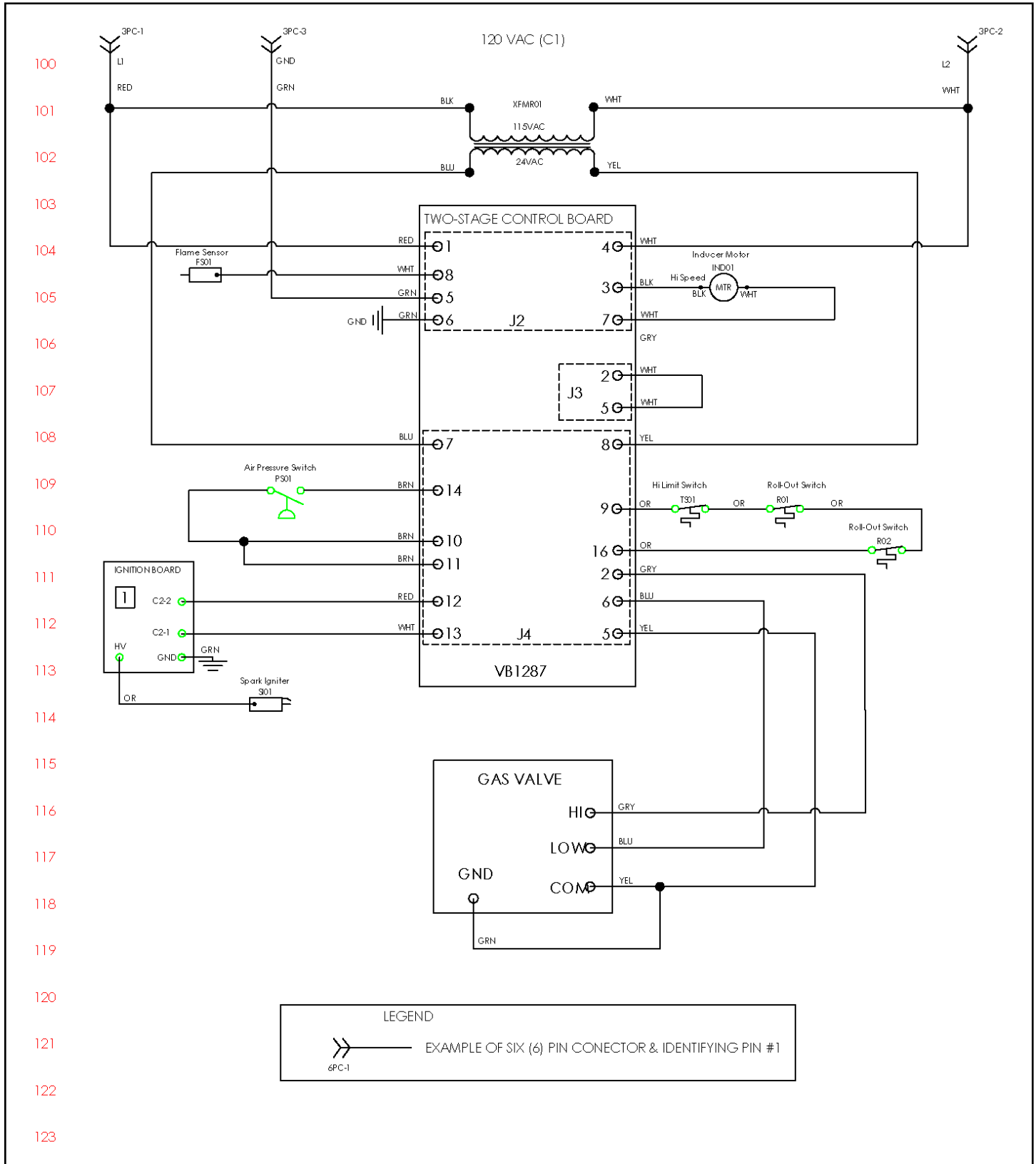

Figure 86: Rebel B Cabinet (Sizes 07-17) 5:1 Modulating Furnace Wiring Diagram

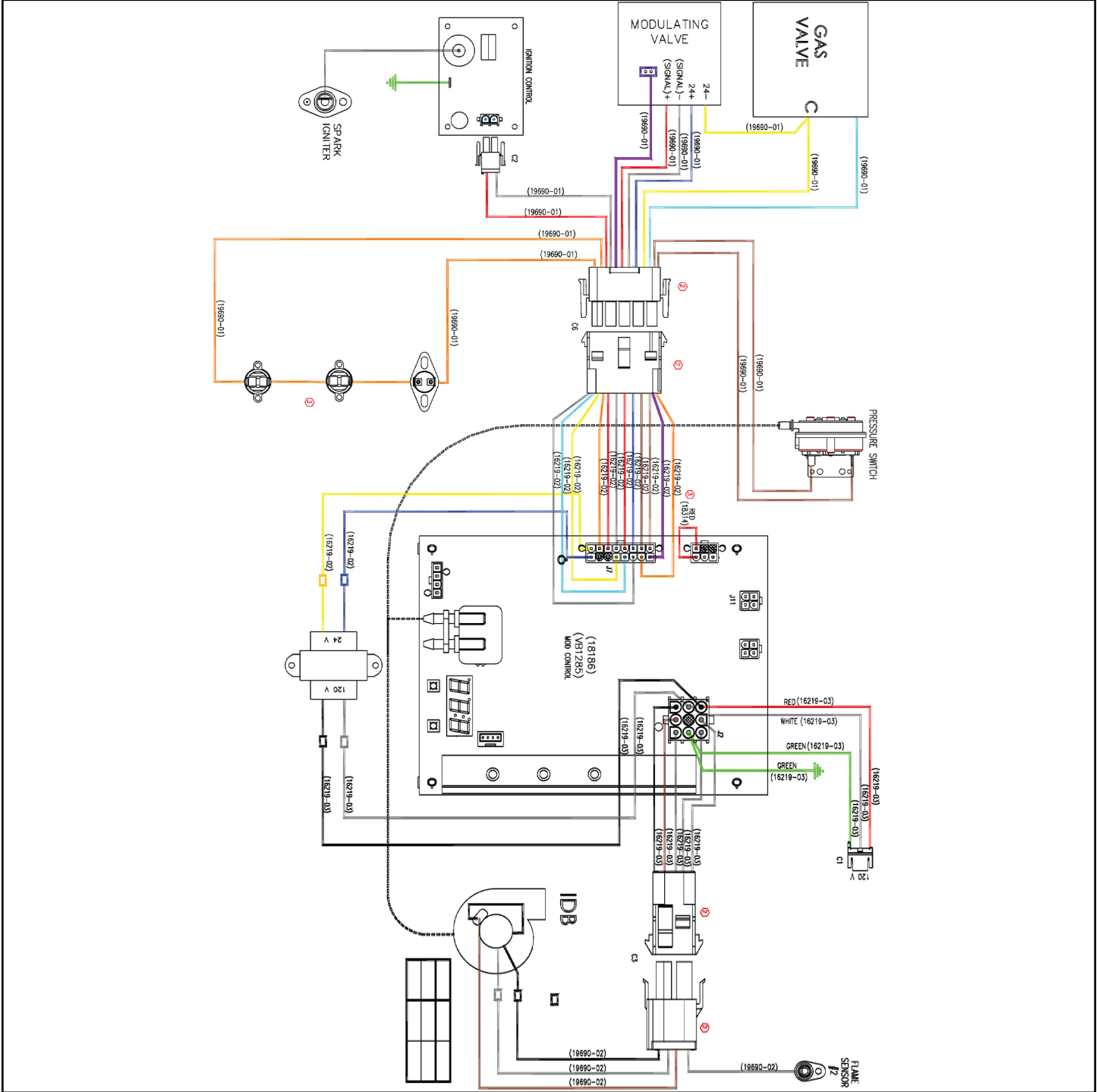

Figure 87: Rebel B Cabinet (Sizes 07-17) 5:1 Modulating Furnace Electrical Schematic and Pinout Detail

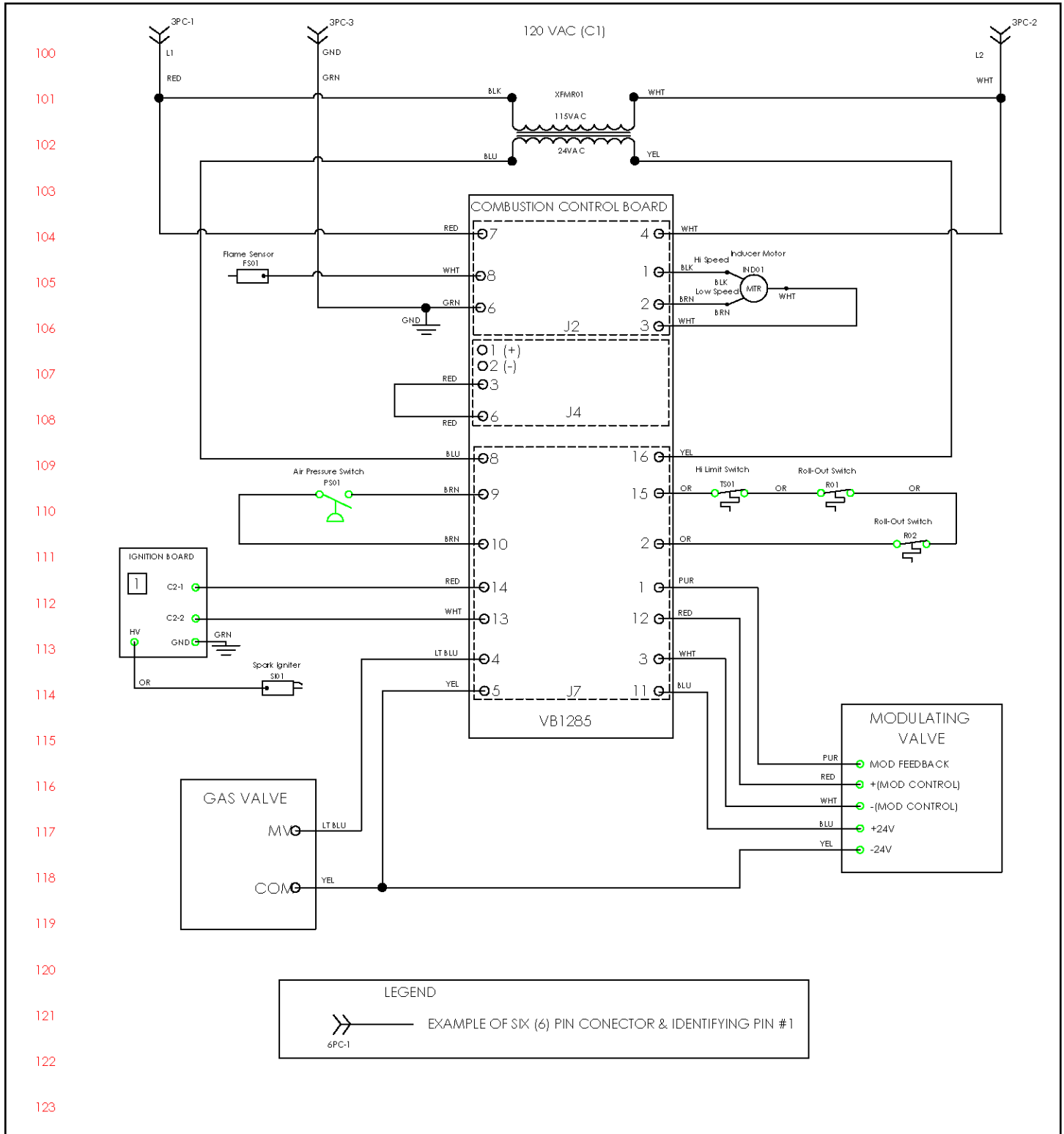

Figure 88: Rebel B Cabinet (Sizes 07-17) 10:1 Modulating Furnace Wiring Diagram

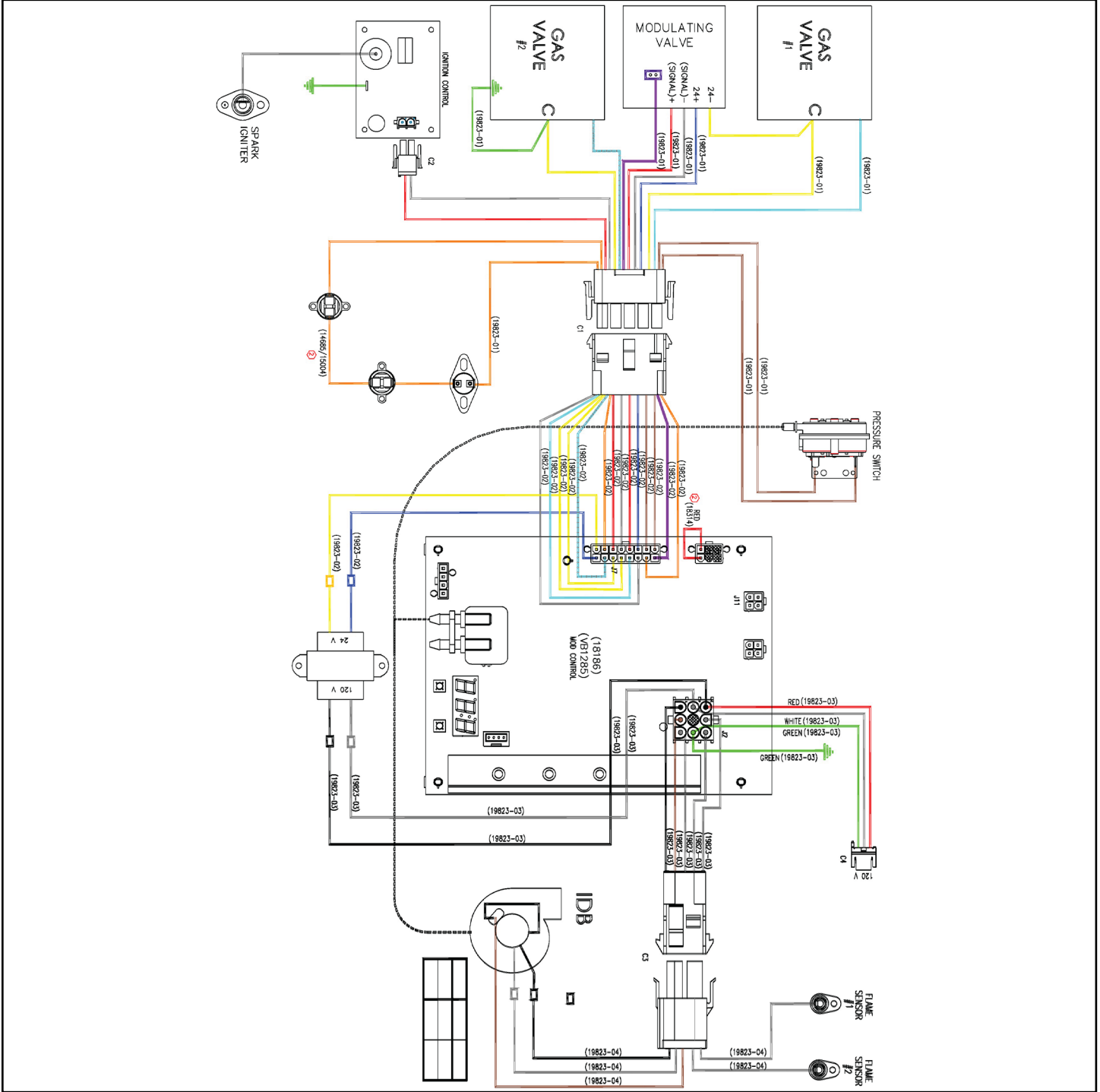

Figure 89: Rebel B Cabinet (Sizes 07-17) 10:1 Modulating Furnace Electrical Schematic and Pinout Detail

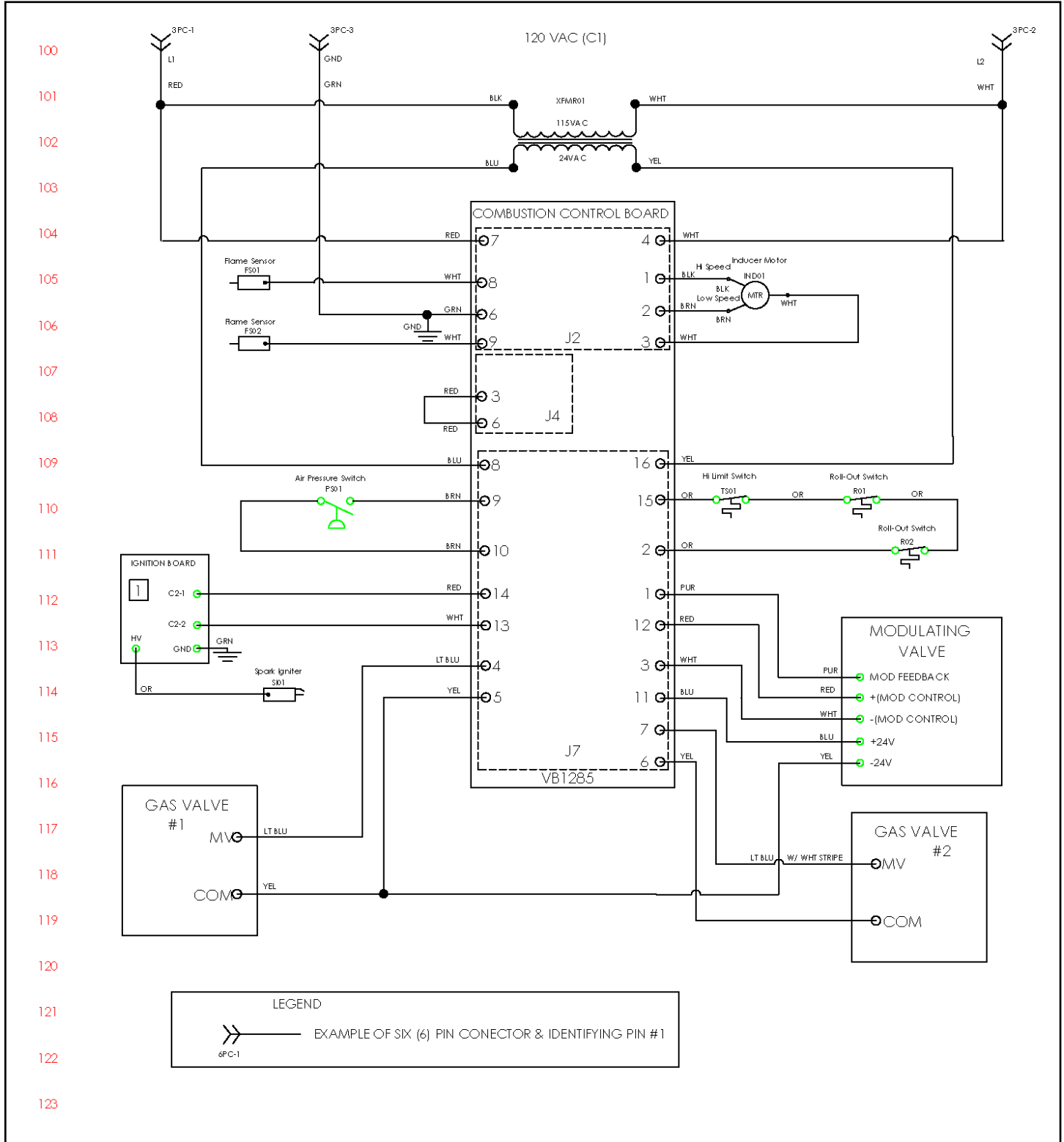

Figure 90: Rebel C Cabinet (Sizes 016-31) 2-Stage, 300 MBH Furnace Wiring Diagram

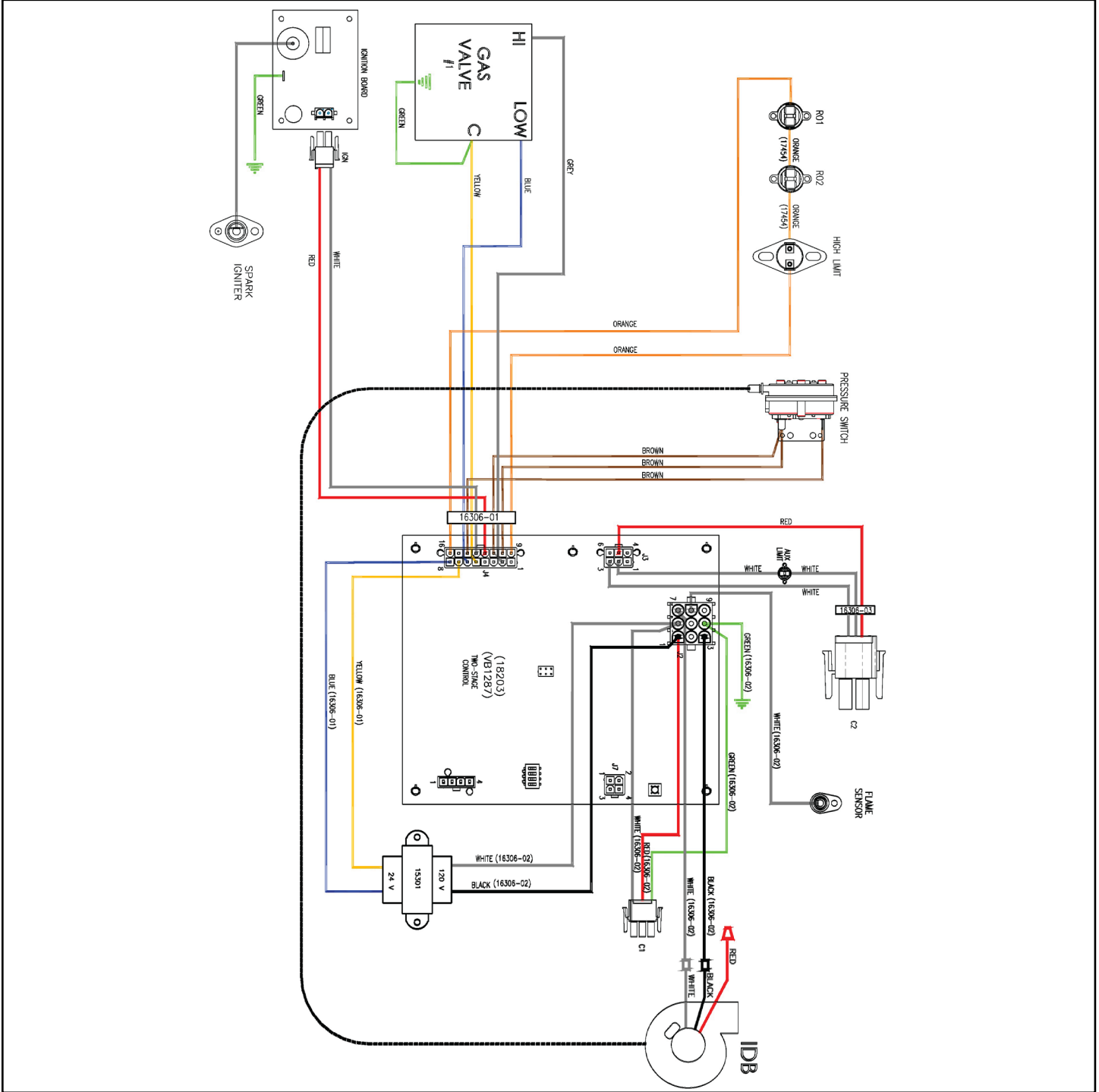

Figure 91: Rebel C Cabinet (Sizes 016-31) 2-Stage, 300 MBH Furnace Electrical Schematic and Pinout Detail

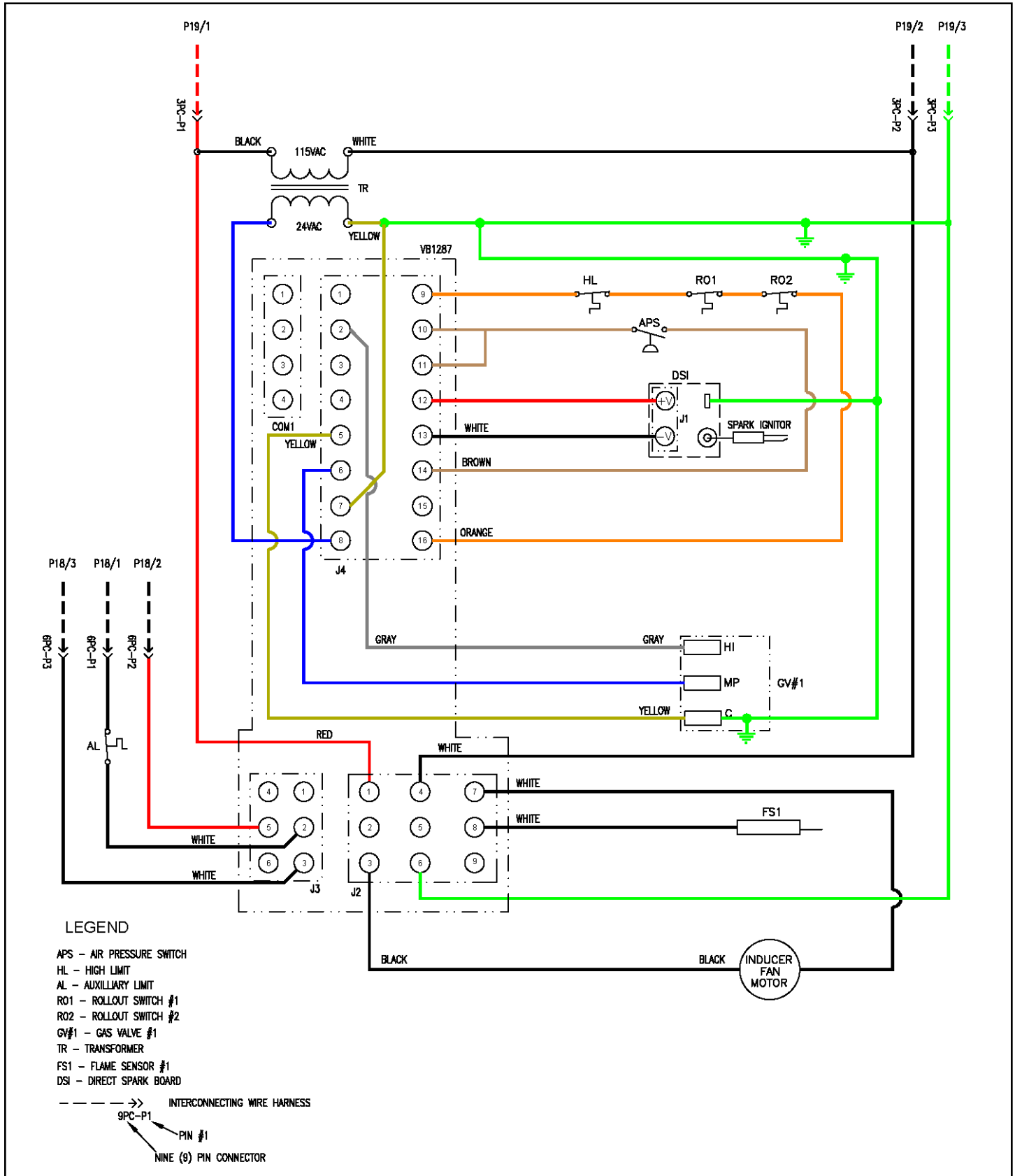

Figure 92: Rebel C Cabinet (Sizes 016-31) 2-Stage, 450/600 MBH Furnace Wiring Diagram

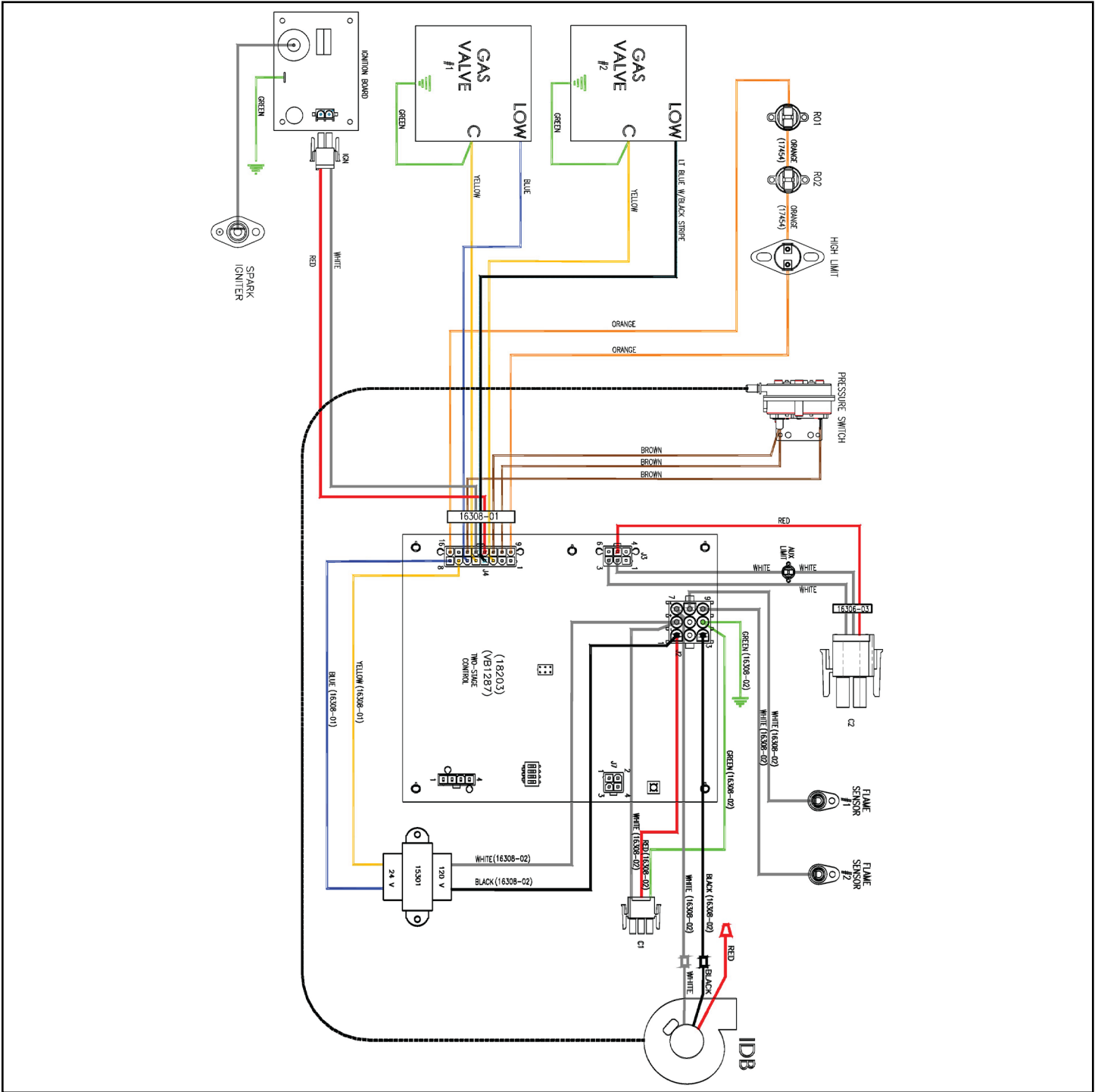

Figure 93: Rebel C Cabinet (Sizes 016-31) 2-Stage, 450/600 MBH Furnace Electrical Schematic and Pinout Detail

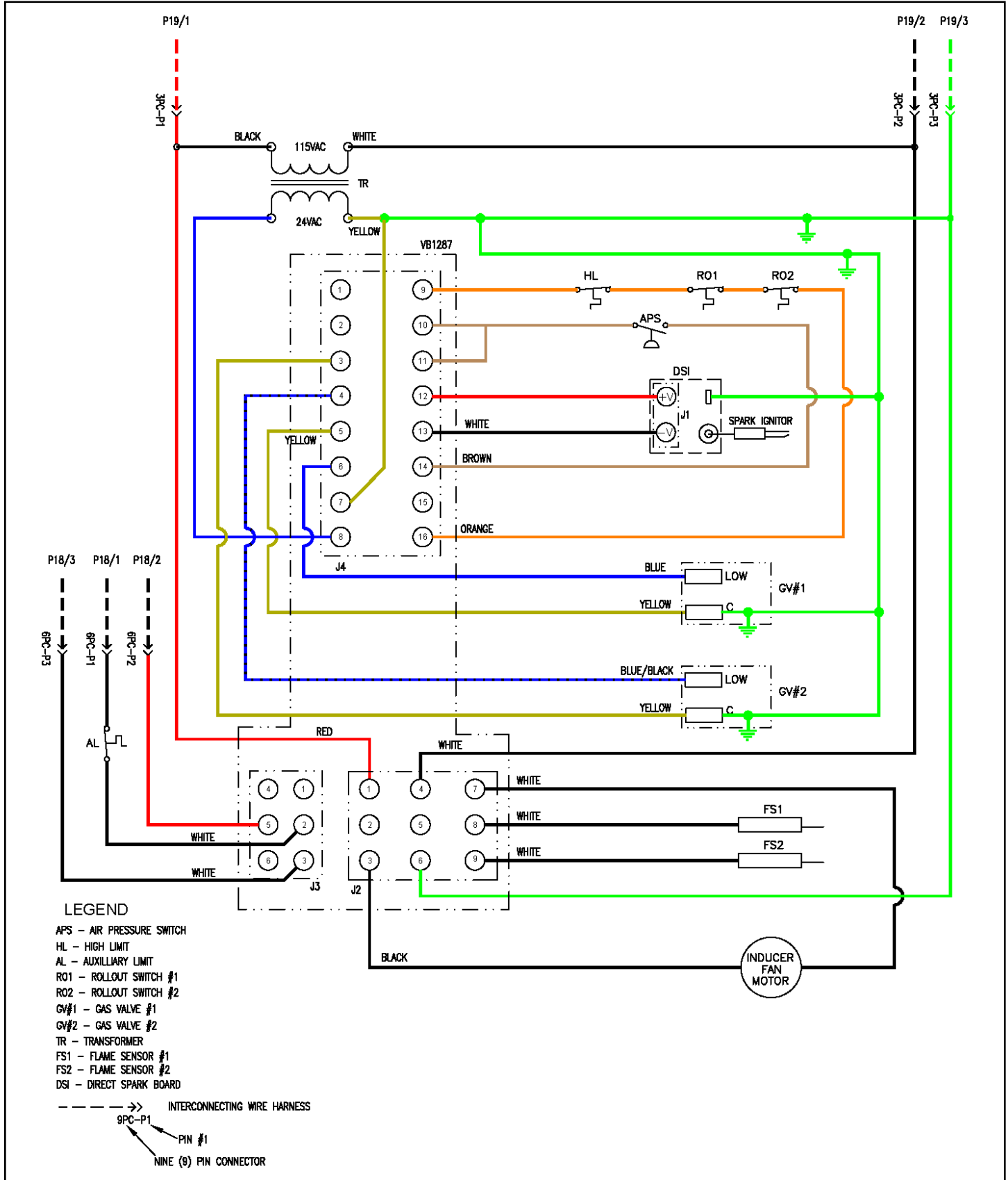

Figure 94: Rebel C Cabinet (Sizes 016-31) 4-Stage Furnace Wiring Diagram

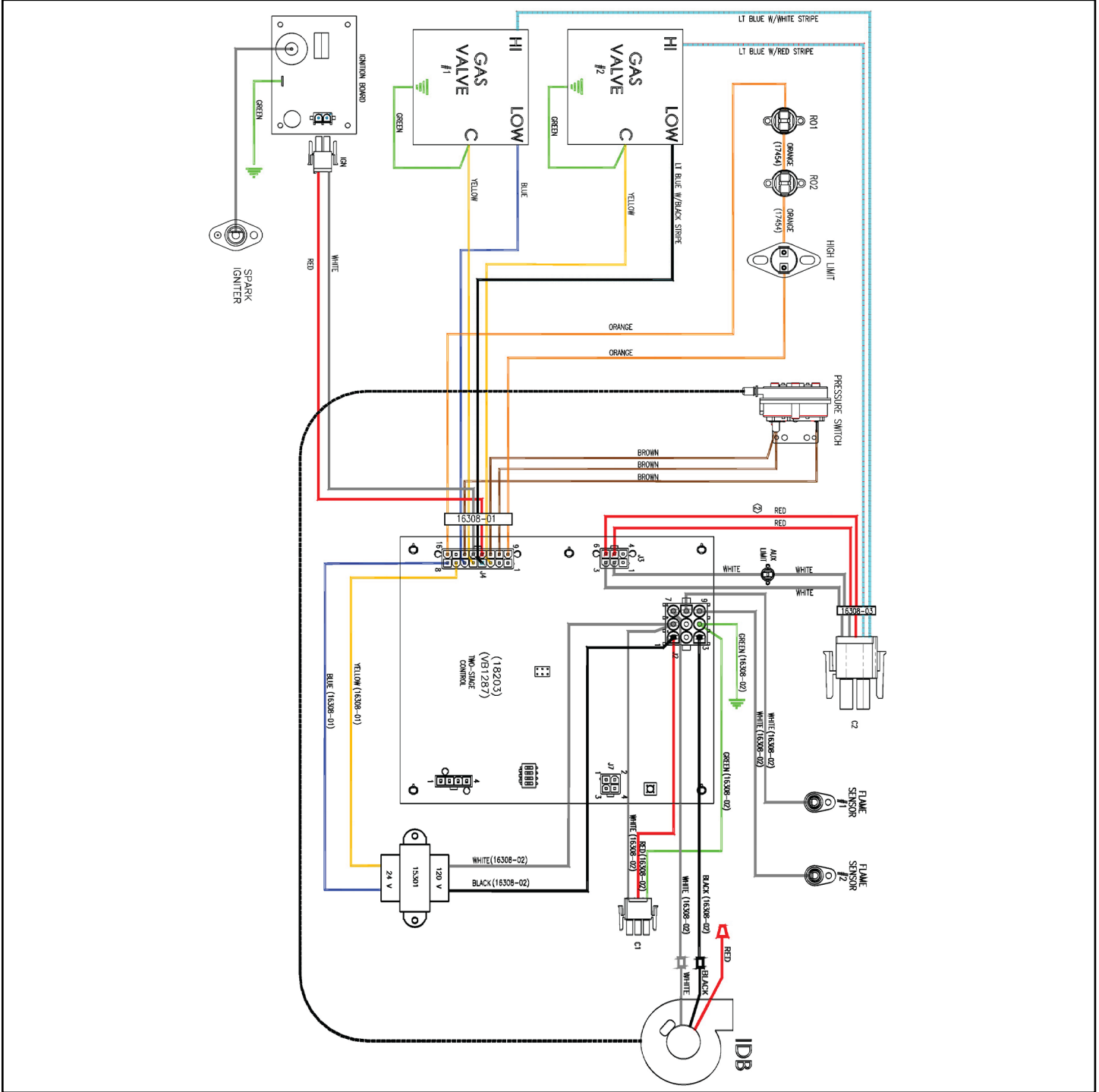

Figure 95: Rebel C Cabinet (Sizes 016-31) 4-Stage Furnace Electrical Schematic and Pinout Detail

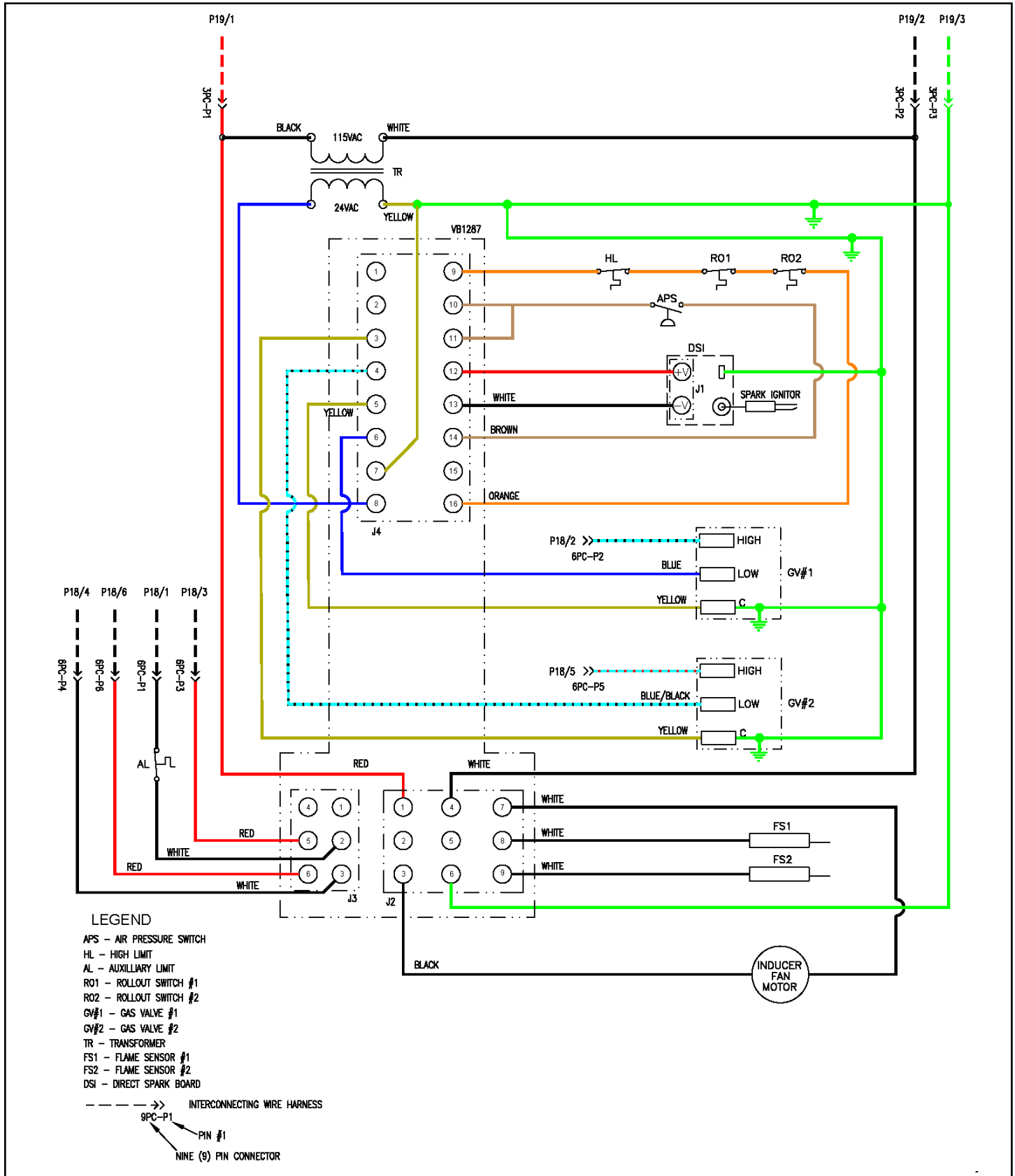

Figure 96: Rebel C Cabinet (Sizes 016-31) Modulating Furnace Wiring Diagram (1)

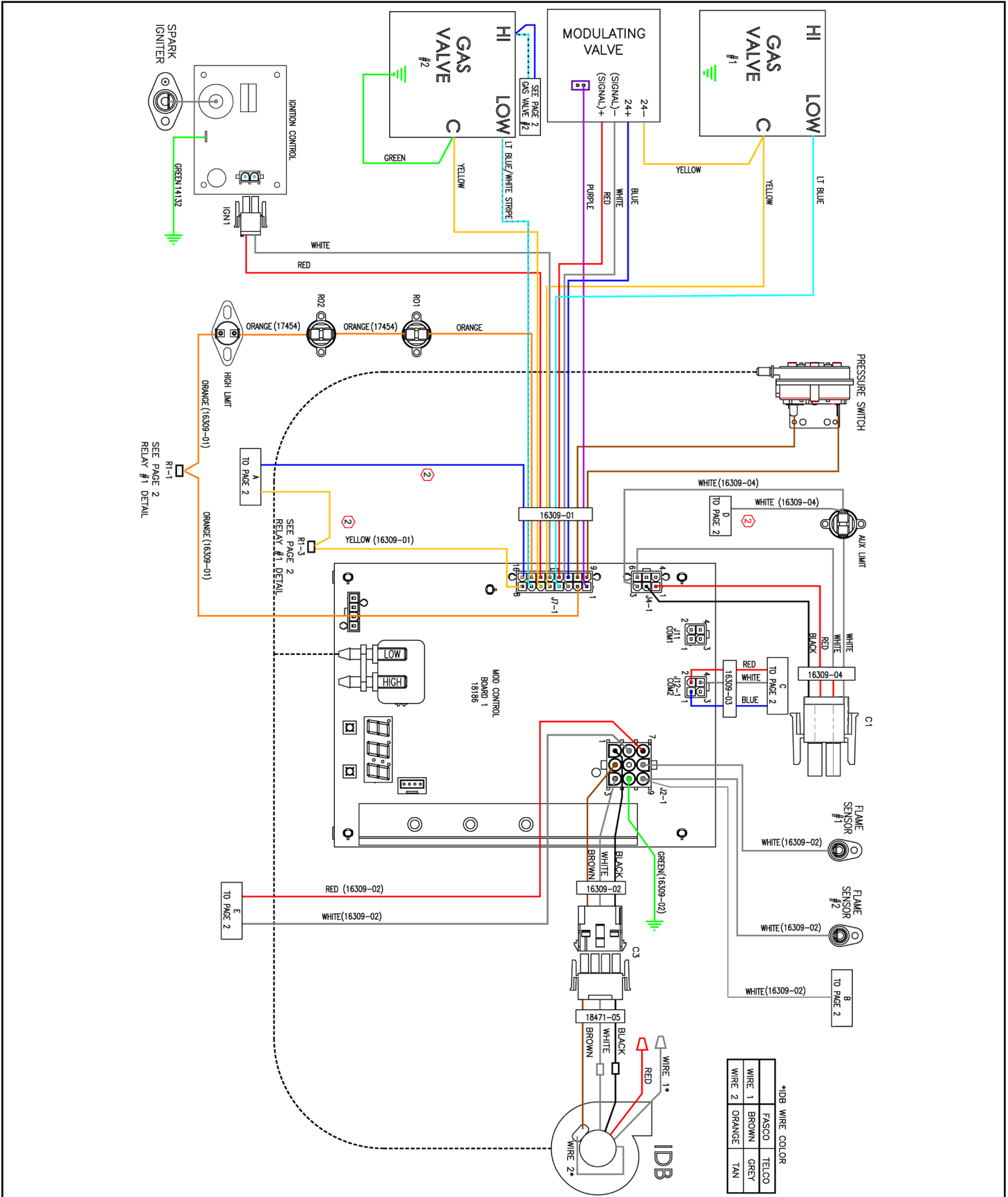

Figure 97: Rebel C Cabinet (Sizes 016-31) Modulating Furnace Wiring Diagram (2)

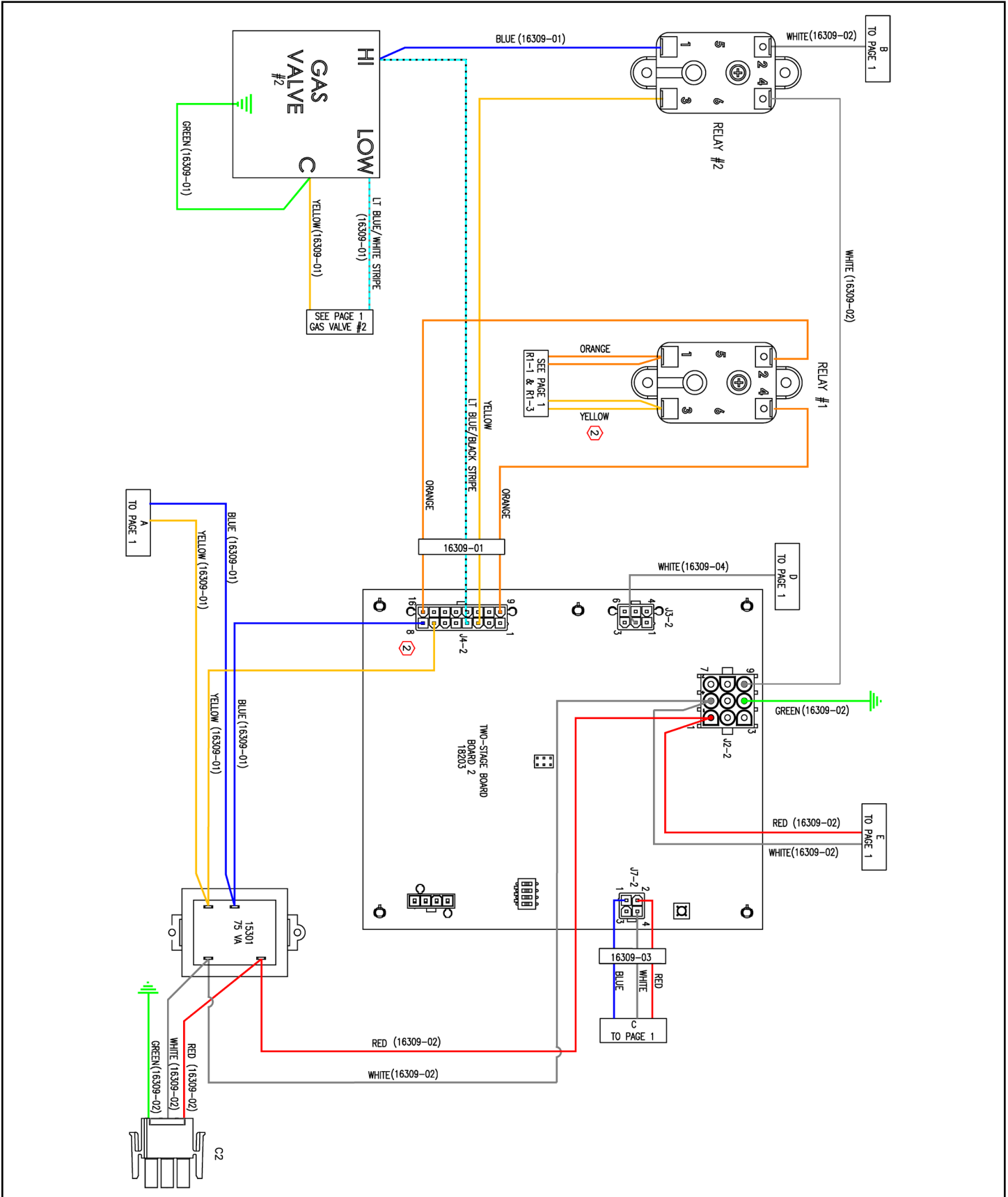

Figure 98: Rebel C Cabinet (Sizes 016-31) Modulating Furnace Electrical Schematic and Pinout Detail (1)

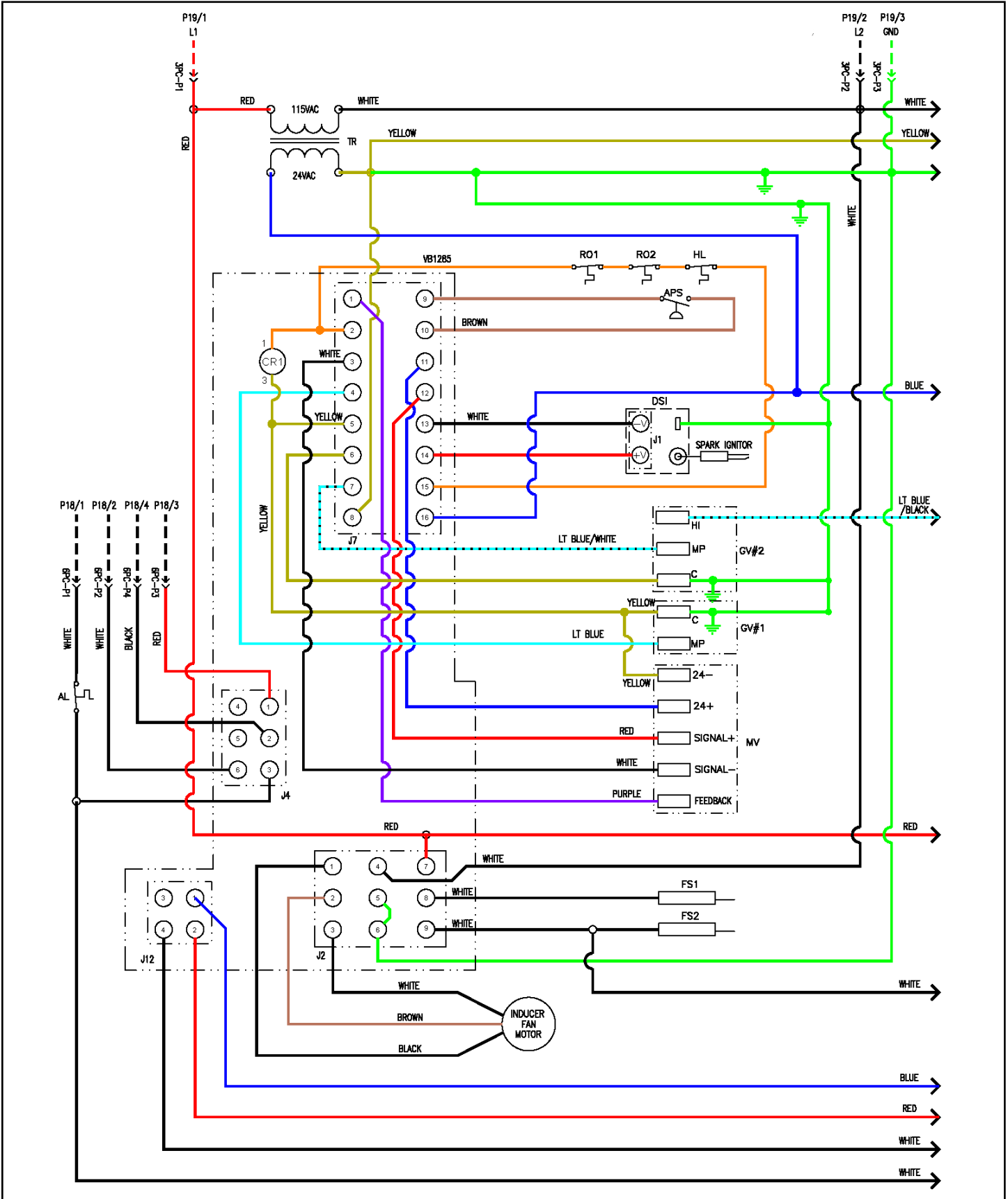
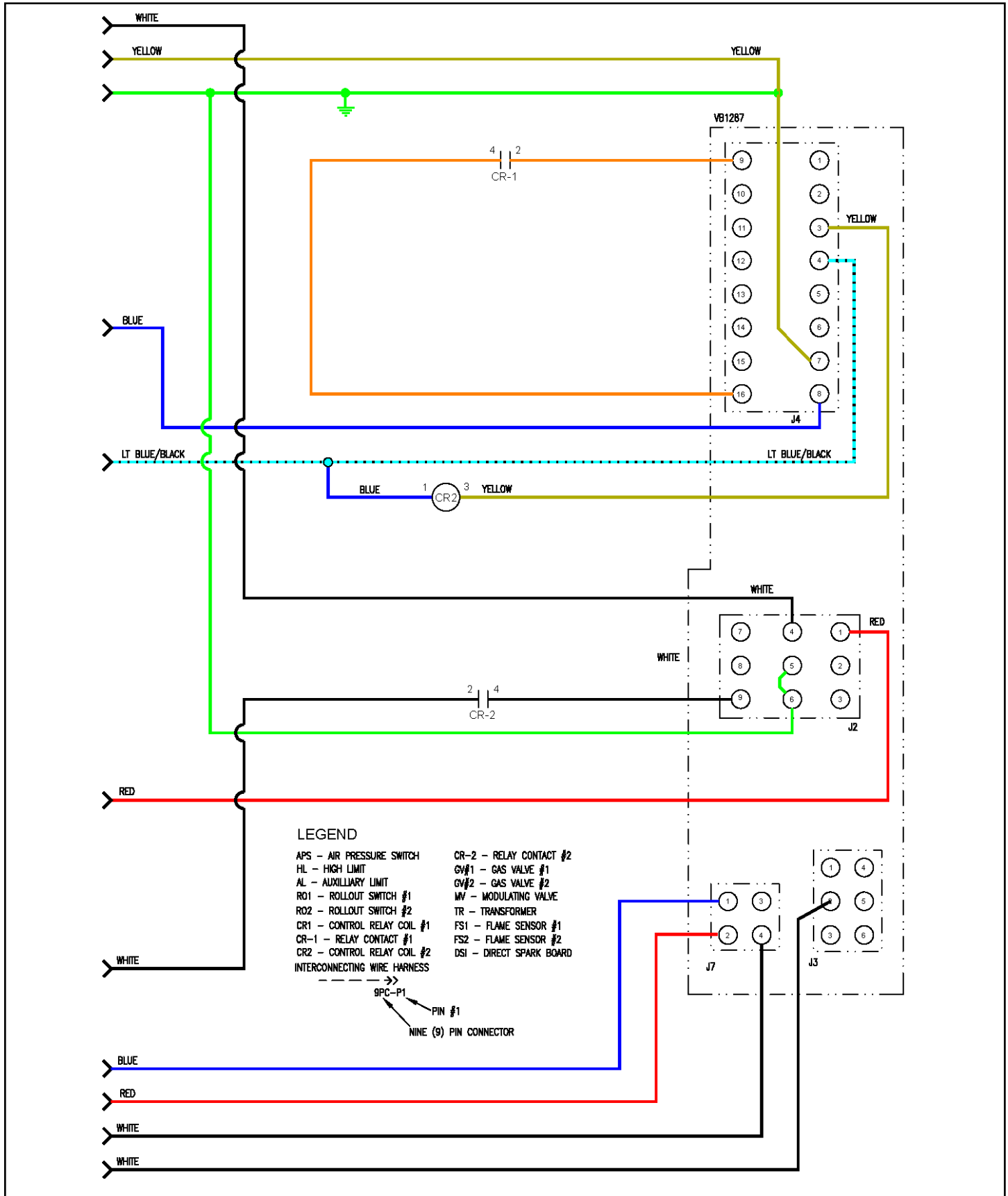

Figure 99: Rebel C Cabinet (Sizes 016-31) Modulating Furnace Electrical Schematic and Pinout Detail (2)



Gas Furnace Ignition and Control Troubleshooting

VB 1285 Variable Furnace Controller

Daikin Applied's furnace controller is an electronic device that delivers full control of the modulating furnace. Control includes sequencing, ignition, safety, modulation of the control valve, optional control of a second staged valve, and the induced draft motor. Inputs to the furnace control board are provided through Modbus control. The furnace control will modulate the burner down to the furnace's minimum fire rate as shown in [Table 16 on page 53](#) and [Table 17 on page 55](#). Safety inputs include pressure line and electrical connection from the airflow proofing switch and electrical connection from the rollout switches. Control board outputs are to the igniter board, modulating gas valve, optional staged gas valve or staged control board, and to the induced draft motor.

Modulating Furnace Diagnostics

The Rebel furnace control that operates the furnace has built-in, self-diagnostic capability. The control continuously monitors its own operation and the operation of the system. The LED on the control indicates the current system state, warnings, failures and test modes.

Troubleshooting Guide

Table 27: Furnace ID Chip Information (Displayed on Power-Up)

Display Information (example)	Description
C	Furnace series or model name, for example, C cabinet series.
CAB	
400	Furnace size in 1000's of BTU, for example, 400 kBTU.
NAT OR LP	Burner fuel type, for example, natural gas or LP.
GAS OR LP	
1.01	Software version, for example, v1.01

Table 28: Normal Furnace Operation

Display Information	Mode	Description
OFF	OFF Mode	System Idle - Control board has power, no faults found, no call for heat.
PUR	PURGE Mode	System is purging the heat exchanger – No gas on, no flame, inducer runs for the specified purge timings. Purge cycles occur immediately before and after each burner operation.
IGN	IGNITION Mode	System is initiating burner operation – Igniter energized, modulating valve moved to ignition setting, gas on. Maintained for the trial-for-ignition period and the five second flame stabilization period.
HEA	WARM-UP Mode	Period between Ignition and Run – System checks completed before modulation control begins.
RUN	RUN Mode	Normal modulating operation.
RET	Ignition Retry	System has had a failed ignition attempt or has lost flame during burner operation and is beginning another ignition cycle.

VB 1285 Troubleshooting

Table 29: VB 1285 Diagnostic Codes

Display Information	Diagnostic Code	Type	Description	Actions
888	1	Lockout	Board Failure (Also during power up)	Check wiring, replace control
OFF	2	Status	UP Mode: Burner state= Off	Normal - no action required
PUR	3	Status	UP Mode: Burner state = Purge	Normal - no action required
LEIN		Status	UP Mode: Burner state= Ignition	Normal - no action required
HEA		Status	UP Mode: Burner state= Warmup	Normal - no action required
RUN		Status	UP Mode: Burner state= Run	Normal - no action required
RET	4/5	Status	UP Mode: Burner state= Retry	None - burner lost flame and is in retry
AO 1	4	Alert	Failed Ignition attempt	Check for spark, gas valve is on, voltage at gas valve, make sure gas is on.
AO2	5	Alert	Lost Flame	Check and clean flame sensor, check gas supply, valve is on, voltage to valve.
AO3	6	Alert	Insufficient Combustion Air-auto-derating	Check for flue blockage, hose blockage or leakage, proper inducer operation.
AO4	7	Alert	Limited Low Fire (due to Lost Flame Auto Adaption)	Check and clean flame sensor or replace.
AO5	8	Alert	Weak Flame Signal, Main burner	Check and clean flame sensor or replace.
AO7	33	Alert	Air Modulating Failure (Inducer isn't modulating down)	Check for flue blockage, hose blockage or leakage, proper inducer operation.
AO8	34	Alert	Air Sensor Null Pressure Check (out of tolerance)	Check pressure switch is closed during normal operation, check hoses for leaks.
A 11	24	Alert	Failed Ignition, Split manifold burner, retries exhausted	Check gas valve is on, voltage to valve.
A 15	10	Alert	Weak Flame Signal, one or more split-manifold staged burners	Check and clean flame sensor, make sure immersed in flame. Check manifold pressure.
EO 1	11	Lockout	Failed Ignition, retries have been exhausted	Check for spark, gas valve is on, voltage at gas valve, make sure gas is on.
EO2	12	Lockout	Primary Limit Failure (or open fuse)	Check unit airflow, filters and blower motor operation, reset power to control.
EO3	13	Lockout	Modulating Valve Failure	Check AC and DC voltage to valve
EO4	14	Lockout	Air Pressure Sensor Reading Low (Pressure switch failed to open or insufficient air/blocked vent)	Check for flue blockage, hose blockage or leakage, proper inducer operation.
EO5	15	Lockout	Air Pressure Sensor Reading High (Pressure switch failed to close)	Check for flue blockage, hose blockage or leakage, proper inducer operation.
EO8	18	Lockout	Unexpected flame, Main burner	Check for short to ground on flame sensor, check wiring.
EO9	19	Lockout	No R-W enable signal during CFH	Check wiring and component in circuit for proper operation.
E 13	23	Lockout	Open fuse	Check for shorts in 24V circuit.
E 18	22	Lockout	Unexpected flame, Split manifold burner	Check for short to ground on flame sensor, check wiring.
EO	20	Lockout	Invalid ID Chip Installed	Remove and check ID plug connections, reset power if problem persists replace ID plug.

Maxitrol EXA Star Valve Over-Traveled State Calibration

WARNING

Adjusting the modulating valve beyond its physical limits may result in permanent damage to the valve and production of carbon monoxide (CO) during modulation. Serious personal injury and death can result if not adjusted correctly. All adjustments should be made by a qualified service agency in accordance with the manufacturer's instructions and all applicable codes and requirements of the authority having jurisdiction. If the information in these instructions is not followed exactly, a fire, an explosion, or the production of carbon monoxide may result, causing property damage, personal injury, or loss of life. The qualified service agency performing this work assumes the responsibility for the proper adjustment of the appliance.

Follow the procedure detailed here if there has been an inadvertent adjustment to the Maxitrol EXA Star valve, resulting in a mechanically over-traveled state.

Indications of a mechanically over-traveled gas valve include:

- Acceptable combustion measurements while heating section is in modulating state are not achievable. An example of this would be elevated levels of carbon monoxide (CO).
- Modulating gas valve does not retain high/low fire settings upon unit power cycle.

Tools Required

- Electrical Multimeter
- Manometer

Before Proceeding with Calibration

Refer to the heating section manifold for the low and high fire setpoint WC pressure.

Calibration Procedure

1. Cycle power to the unit.
2. When power has returned, use the MicroTech unit controller's "Manual Control" menu to set the heating output to 100%.

NOTE: Ensure all required dampers are opened and adequate airflow is provided across the heating section prior to setting the heating output to 100%. Supply air fan and dampers can be commanded through the "Manual Control" menu.

3. Verify inlet pressure to the modulating valve is 4.75-5.00" WC
4. Press and hold button #2 to enter low fire setting mode. Refer to "Valve Setting" on page 99.
5. Adjust gas flow slowly by pressing and releasing button #2 repeatedly until the desired low fire manifold pressure is reached.
 - Refer to the heating section manifold for the low fire set point WC manifold pressure.
 - Do not press and hold the button as the step rate will increase rapidly and may result in an over-traveled state.

6. Press and hold both button #1 and button #2 simultaneously to save the low fire setting.
7. Press and hold button #1 to enter high fire setting mode. Refer to "Valve Setting" on page 99.
8. Adjust manifold pressure by slowly pressing and releasing button #2 repeatedly to set the valve to 1.5-2.0" WC
 - Do not press and hold the button as the step rate will increase rapidly and may result in an over-traveled state.
9. Press and hold both button #1 and button #2 simultaneously to save the high fire setting.
10. Cycle power to the unit.
11. When power has returned, use the MicroTech unit controller's "Manual Control" menu to set the heating output to 100%. If the manifold pressures do not come back to where they were set before the power cycle, repeat Steps 4 through 8.

NOTE: Ensure all required dampers are opened and adequate airflow is provided across the heating section prior to setting the heating output to 100%. Supply air fan and dampers can be commanded through the "Manual Control" menu.

NOTE: It may take more than one cycle to bring the valve into normal operating range.

12. If manifold pressures return to the values that were set before the power cycle, continue with Step 13.
13. Press and hold button #1 to enter high fire setting mode. Refer to "Valve Setting" on page 99.
14. Verify inlet pressure to the modulator valve is 4.75-5.00" WC
15. Increase manifold pressure by pressing and releasing button #1 repeatedly.
 - Do not press and hold the button as the step rate will increase rapidly and may result in an over-traveled state.
16. Target manifold pressure is 3.2-3.5" WC while the valve is in high setting mode.
 - Refer to the heating section manifold for the high fire set point WC manifold pressure.
17. Press and hold both button #1 and button #2 to save the high fire setting.
 - If the modulating valve is receiving <10 VDC with a maximum demand to the furnace control, there may be a small shift in manifold pressure after the high fire setting is saved.
 - Typically, this will result in 3.2-3.4" WC manifold pressure.
18. Cycle power to the unit.
19. When power has returned, use the MicroTech unit controller's "Manual Control" menu to set the heating output to 100%.

NOTE: Ensure all required dampers are opened and adequate airflow is provided across the heating section prior to setting the heating output to 100%. Supply air fan and dampers can be commanded through the "Manual Control" menu.

20. Observe manifold pressure. If the voltage to the modulating valve is <math><10\text{VDC}</math> at 100% demand to the furnace control, the pressure should be lower than the pressure in Step 16 (at same inlet pressure).
21. Send a call for heat at minimum demand.
22. If manifold pressures at minimum have changed from the previous setting, repeat Steps 4 and 5 to reset.
23. Cycle power to unit and verify settings have been properly saved by sending a call for heat at maximum and minimum demand.

Valve Setting

The Maxitrol EXA Star modulating gas valve series has two (2) buttons and a communication LED for user interface. The buttons are used to set the valve for high and low fire settings as shown in Figure 100.

1. High fire setting - LED will be SOLID red
2. Low fire setting - LED will be BLINKING red
3. Operating Mode - LED will be OFF

Figure 100: Maxitrol EXA Star LEDs

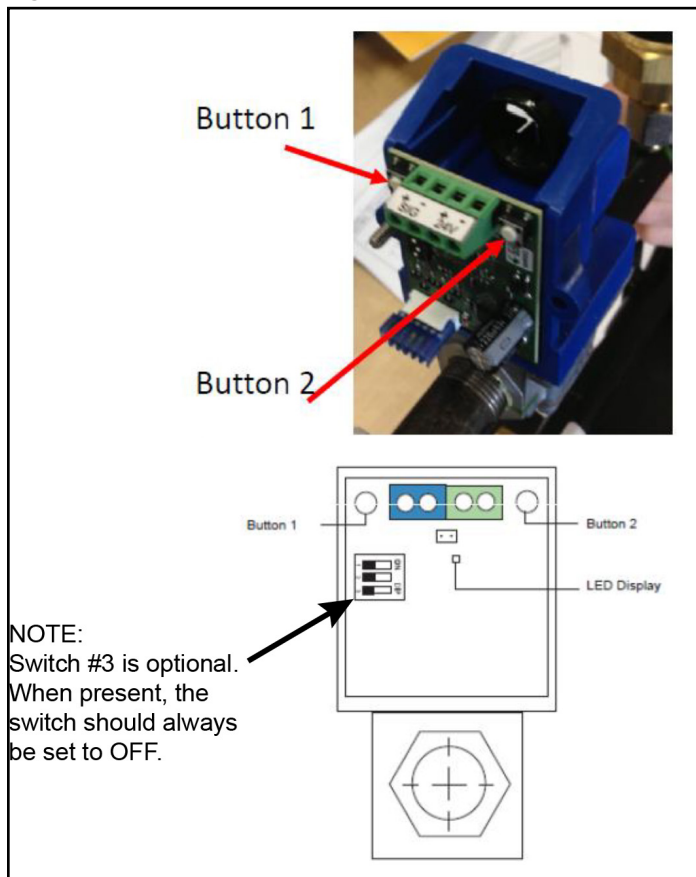

Optional Hot Water Heat

Hot Water Heater Design

CAUTION

Coil freeze possible. Can damage equipment.

Follow instructions for mixing antifreeze solution. Some products have higher freeze points in natural state than when mixed with water. The freezing of coils is not the responsibility of Daikin Applied.

If the 21st digit of the model number is a "W", the rooftop unit was furnished with a factory installed hot water coil. The hot water coil comes with a piping vestibule for field supplied and installed control valve and piping. The coil is furnished with ODM copper connections. The Rebel commercial rooftop units are available with a low heat (one row coil) or a high heat (two row coil) configuration (3 row coil).

Hot water coils are not recommended for use with entering air temperatures less than 40°F (4°C). No control system can guarantee a 100% safeguard against coil freeze up. Glycol solutions or brines are the only freeze-safe media for operation of water coils at low entering air temperatures.

See certified drawings for the recommended piping entrance locations. Seal all piping penetrations to prevent air and water leakage.

NOTE: Factory installed piping is copper. Dissimilar metal within the plumbing system can cause galvanic corrosion. To avoid corrosion, provide proper di-electric fittings as well as appropriate water treatment.

Figure 101: Hot Water Piping (Sizes 03-06)

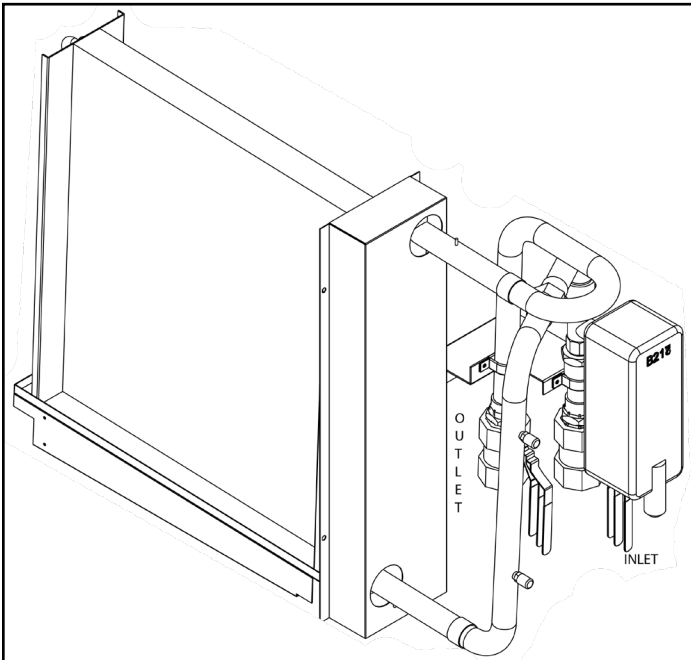

Figure 102: Hot Water Piping (Sizes 07-31)

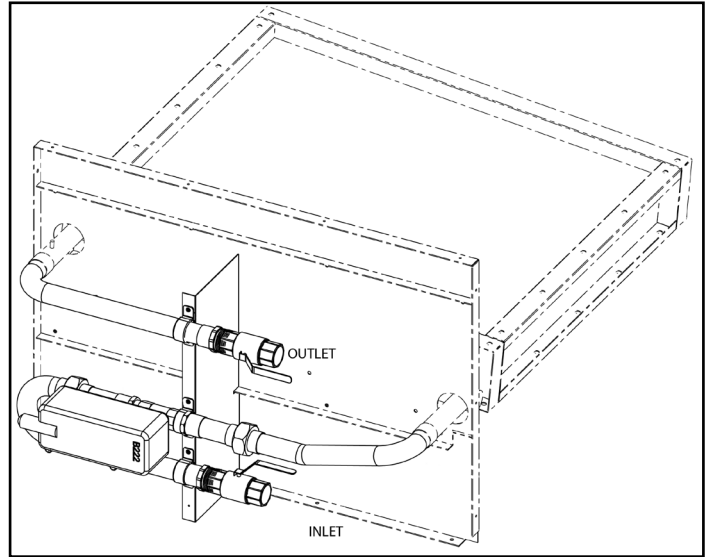
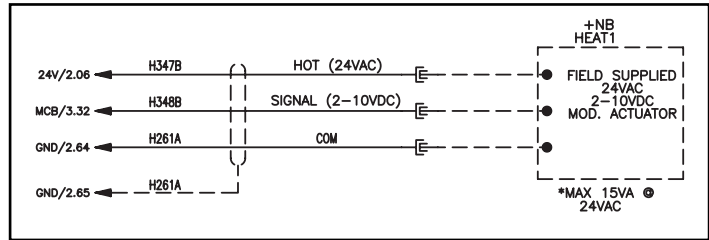

Figure 103: Hot Water Heating Schematic



Field Installed Freeze Stats

Field installed freeze stats can be added. The freeze stat contacts should be wired to the MicroTech unit controller. MicroTech unit controller will turn the fans OFF, shut the outdoor air damper, open the valve and issue an alarm when the normally closed contact opens.

Figure 104: Field Installed Freeze Stat Schematic

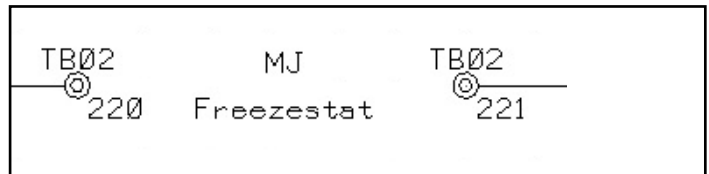

Table 30: Hot Water Coil Connection Sizes

Unit	No Valve Package	Valve Package, No Isolation	Isolation Valves
A Cabinet (03-06)	1.125" Sweat	1.125 MPT	1" NPTF
B Cabinet (07-17)	1.375" Sweat	1.375" MPT	1.25" NPTF
C Cabinet (16-31)	1.625" Sweat	1.625" MPT	1.5" NPTF

Energy Recovery Wheel

System Description

When a unit is equipped with an optional enthalpy wheel, energy recovery is provided by drawing outside air across half of the enthalpy wheel and drawing exhaust air across the other half. Latent heat and sensible heat are transferred from the hotter and moist exhaust air to the colder and dry outside air during winter conditions. Latent heat and sensible heat are transferred from the hotter and moist outside air to the cooler and dry exhaust air during summer conditions. Energy recovery control consists of starting and stopping an exhaust fan, modulating the speed of the exhaust fan, starting and stopping an enthalpy wheel, optionally controlling the speed of the enthalpy wheel and opening and closing a set of bypass dampers. The outdoor dampers are controlled in the normal manner.

Definitions

The following are descriptions of various components related to the enthalpy wheel construction (Figure 105):

Bearing, external - The wheel and bearing rotate on the shaft, no field lubrication is required.

Brush seal - The seal used for both the circumferential seal and the inner seal in the cassettes. They are constructed of nylon brush and configured to seal against the enthalpy wheel band in the case of the circumferential seal, and against the wheel face in the case of the inner seal. These seals are full contact seals, have an integral clip, and they are clipped to the cassette face panel cutout (circumferential) or to the (inner) post.

Cassette - The steel structure that houses the rotor. Cassettes are of punched sheet metal panel construction.

Enthalpy wheel - A generic name for an energy conservation wheel. The term "enthalpy" refers to an air stream's total energy (temperature and humidity level).

Exhaust air - The air stream that is exhausted to the outside. Exhaust air is building return air that has been run through the enthalpy wheel.

Heat wheel - Synonymous with an enthalpy wheel, energy conservation wheel, or total energy recovery wheel. Some heat wheels are sensible only wheels and should not be confused with Daikin Applied total energy recovery wheels.

Hub - The center support of an enthalpy wheel.

Latent energy - Latent energy, in the context of enthalpy wheel discussions, is the work done by the wheel to transfer moisture from one air stream to another. Latent work is accompanied by humidity changes in the air streams.

Media - The chemical composite part of the enthalpy wheel which actually performs the latent and sensible exchange.

Outdoor air - The air stream that is brought in from the outside. Outdoor air becomes supply air after going through the enthalpy wheel.

Purge - A small segment of supply air defined by the gap between the inner seal on the outdoor air edge of the center post and the supply air edge of the center post. The purge angle is adjustable. The purge captures the small amount of supply air captive in the enthalpy wheel when the wheel moves from return to supply and routes it to return to minimize cross contamination.

Return air - The air stream that is returned from the building. Return air becomes exhaust air after going through the enthalpy wheel.

Rotor - The part of an enthalpy wheel that performs the energy exchange and consists of the wheel media, hub, spokes and band.

Sensible heat - Sensible energy, in the context of enthalpy wheel discussion, is the work done by the enthalpy wheel to transfer heat from one air stream to another. Sensible work is accompanied by temperature changes in the air stream.

Supply air - The air stream that is supplied to the building space. Supply air is outdoor air that has been run through the enthalpy wheel.

Arrangements

Two arrangements are offered for the enthalpy wheel:

1. Single enthalpy wheel with economizer and bypass (Figure 105). This arrangement is available for all units.
2. Single enthalpy wheel without economizer (100% outdoor air unit).

Wheel Construction

Your Daikin Applied enthalpy wheel is delivered completely assembled and ready to run. The wheel is built to provide many years of trouble free service following proper installation and performance of the minimal maintenance requirements.

Figure 105: Wheel Construction (Side-by-Side)

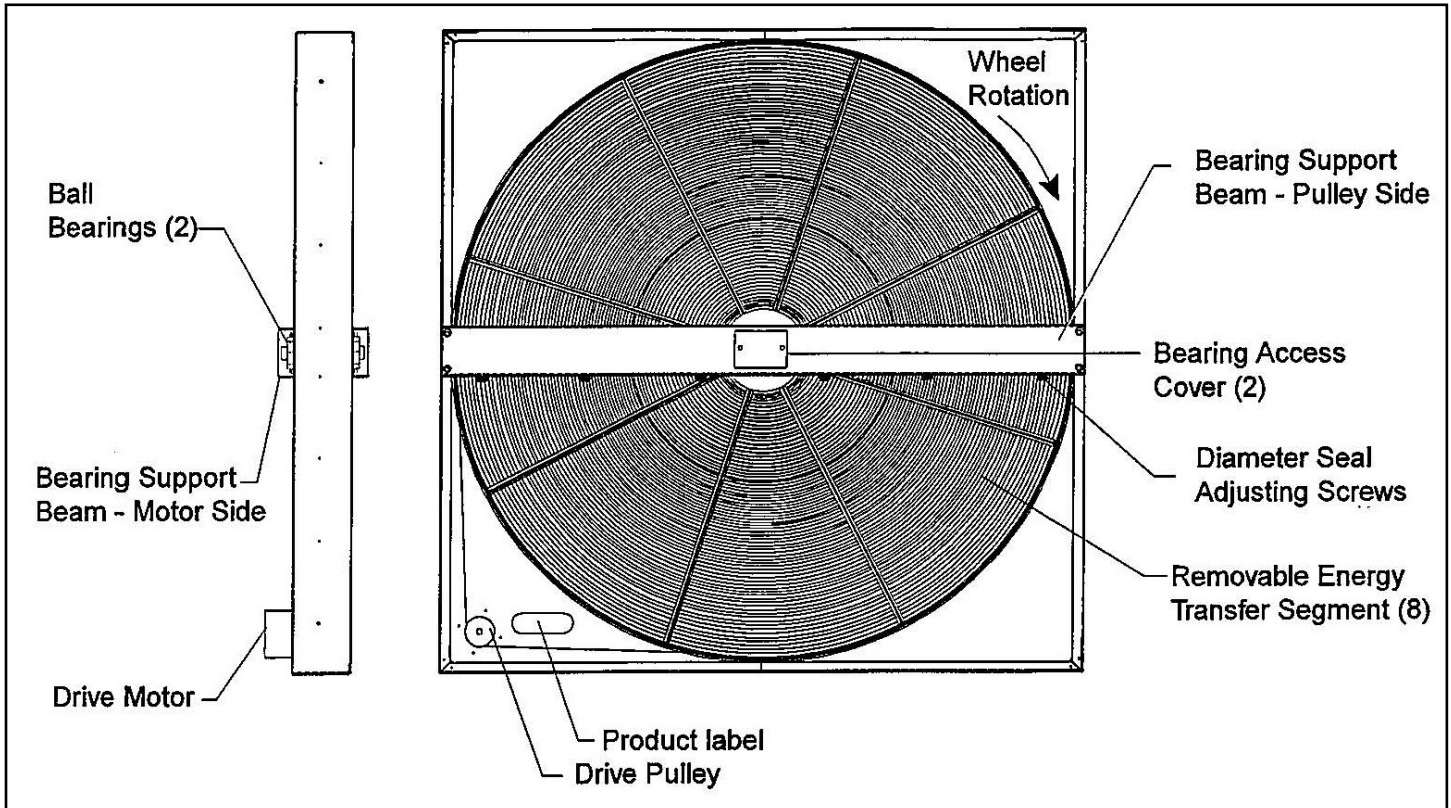

NOTE: Currently, only the Over-Under configuration is offered on Daikin Applied rooftop systems and air handlers.

Purge and Pressurization

Pressurization is critical to minimize crossover from exhaust to supply and to allow the purge to operate.

Figure 106: Purge and Pressurization

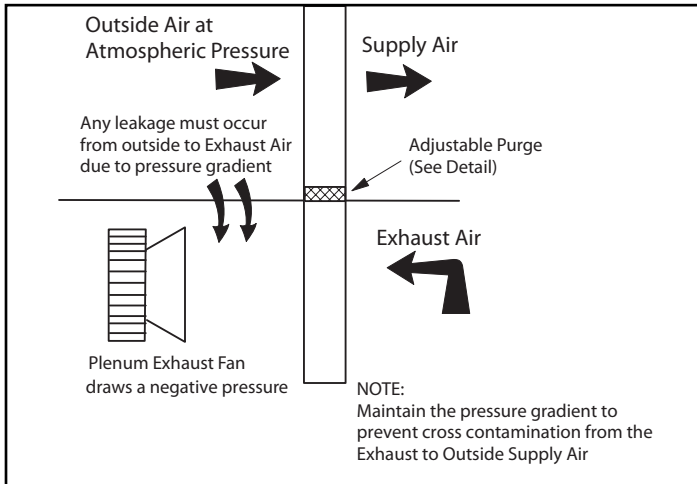
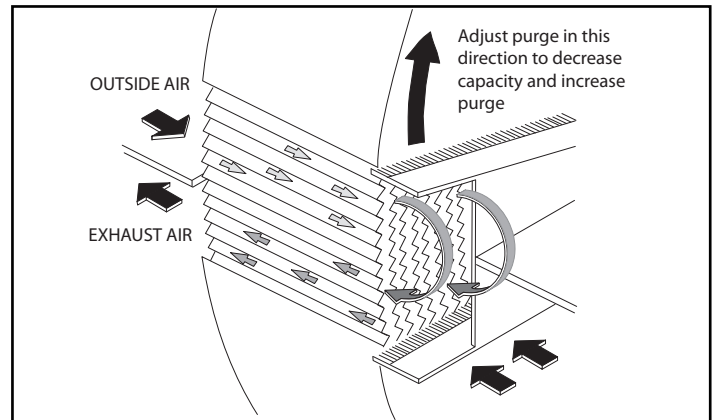

Figure 107: Purge Detail



Drive Motor

The enthalpy wheel comes standard with a constant speed drive motor which is pre-wired to turn in the proper direction.

Frost Protection Option

During extremely cold winter conditions, exhaust air stream may freeze the ERW causing damage. To circumvent this possibility, Daikin Applied offers three factory installed frost protection options with the MicroTech system.

Defrost ON/OFF Control (Standard)

With this method the enthalpy wheel is stopped periodically for a defrost time duration when the outdoor air temperature is below an outdoor frost temperature threshold setpoint.

Figure 108: Frost Prevention Psychrometric Chart

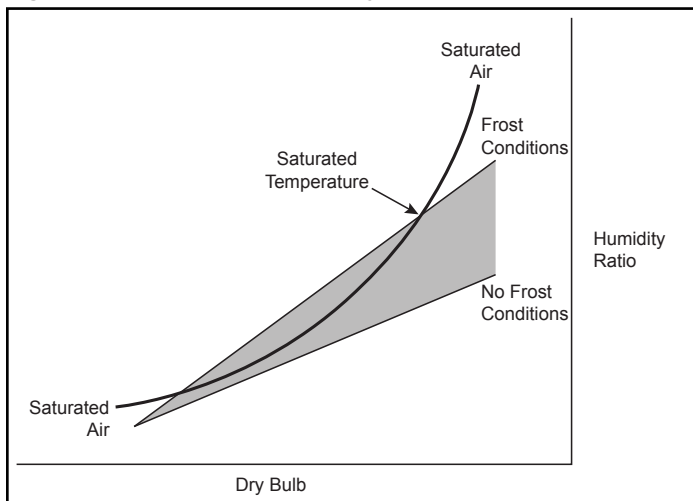

Constant Speed Frost Prevention

When there is a threat of frost on the enthalpy wheel, the wheel is jogged so that less enthalpy transfer occurs and frosting of the wheel is avoided. Frosting can occur on the enthalpy wheel when the exhaust air leaving the wheel is saturated. This condition occurs when two lines intersect on a psychrometric chart, and it does not occur when these two lines do not intersect (see [Figure 108](#)).

Variable Speed Frost Prevention

When there is a threat of frost on the enthalpy wheel, the wheel is slowed down so that less enthalpy transfer occurs and frosting of the wheel is avoided. Frosting can occur on the enthalpy wheel when the exhaust air leaving the wheel is saturated. This condition occurs when two lines intersect on a psychrometric chart, and it does not occur when these two lines do not intersect (see [Figure 108](#)).

Energy Recovery Exhaust Hoods

Units with the optional energy recovery section have one or two exhaust hoods (depending on model). Each hood is shipped in three pieces, consisting of one top and two sides. Install exhaust hood over the barometric relief dampers by installing two sides first and then install the top.

Variable Speed Frequency Control

A variable frequency drive is included with the frost protection option and it controls the speed of the enthalpy wheel. The unit has also been programmed for the recommended range of wheel speed operation. Typical wheel speed is 45 RPM, but the programming can allow for wheel speeds above or below 45 RPM. Check all factory settings to make sure they are consistent with the application.

Enthalpy wheel speed will be controlled by exhaust temperature measurement.

Slide-Out Wheel

The wheel can be pulled out to facilitate cleaning and servicing ([Figure 109](#)). Unplug the control wires before sliding the wheel out of position.

Figure 109: Slide-Out Energy Recovery Wheel

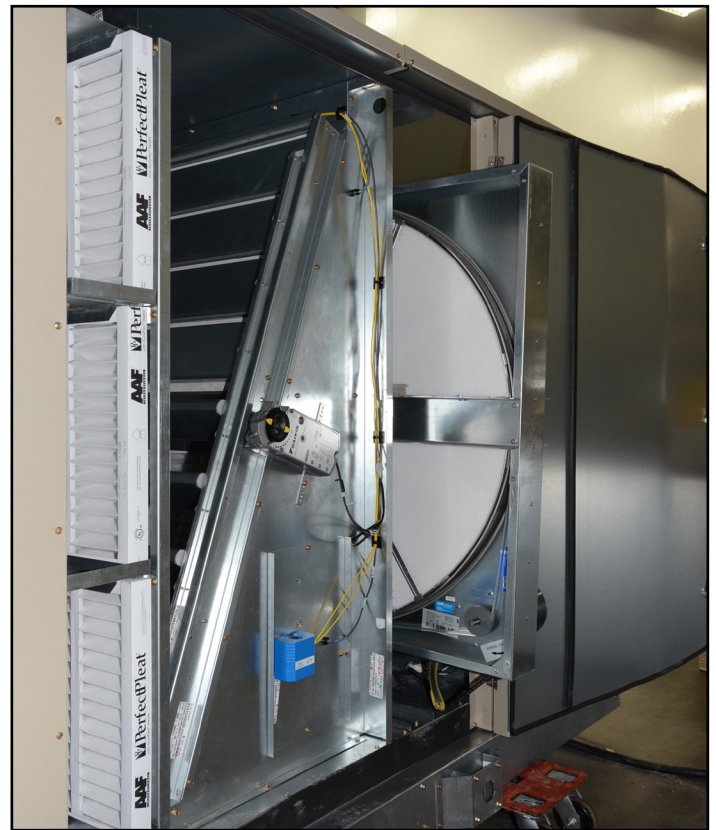

Outdoor Air Monitor

Thermal Dispersion Airflow Measurement Technology

Thermal dispersion technology relates the velocity of the air to the power and rise in temperature of a heated element in a moving airstream. A precise bead-in glass thermistor probes the airflow rate and air temperature. Multiple sensing points are used to produce an average velocity for true volumetric airflow (CFM/ LPS). Each individual sensor node is calibrated to NIST traceable airflow standards at 16 points, resulting in a accuracy of 2% of the reading.

Figure 110: Bead-in-Glass Thermistor

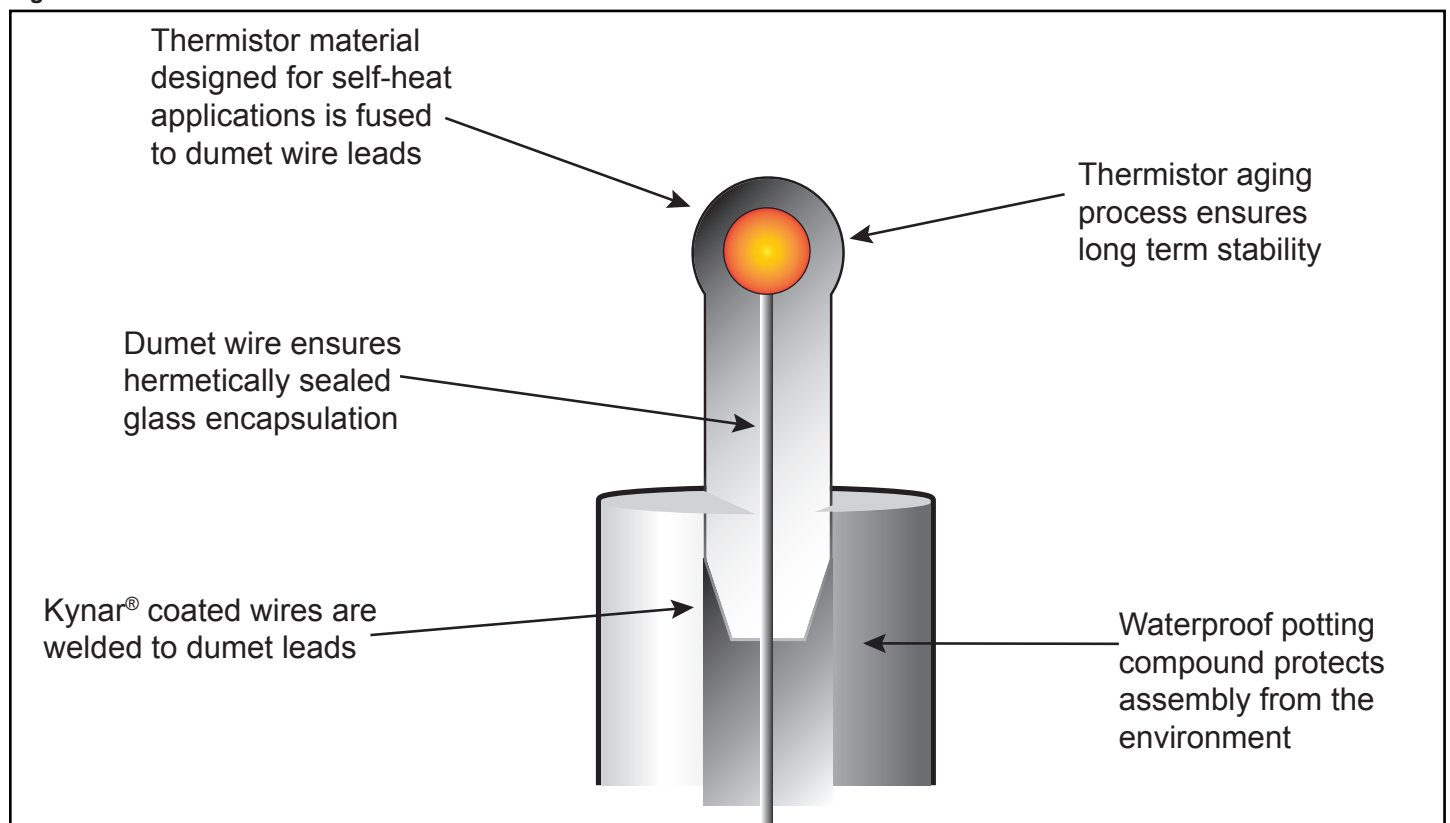
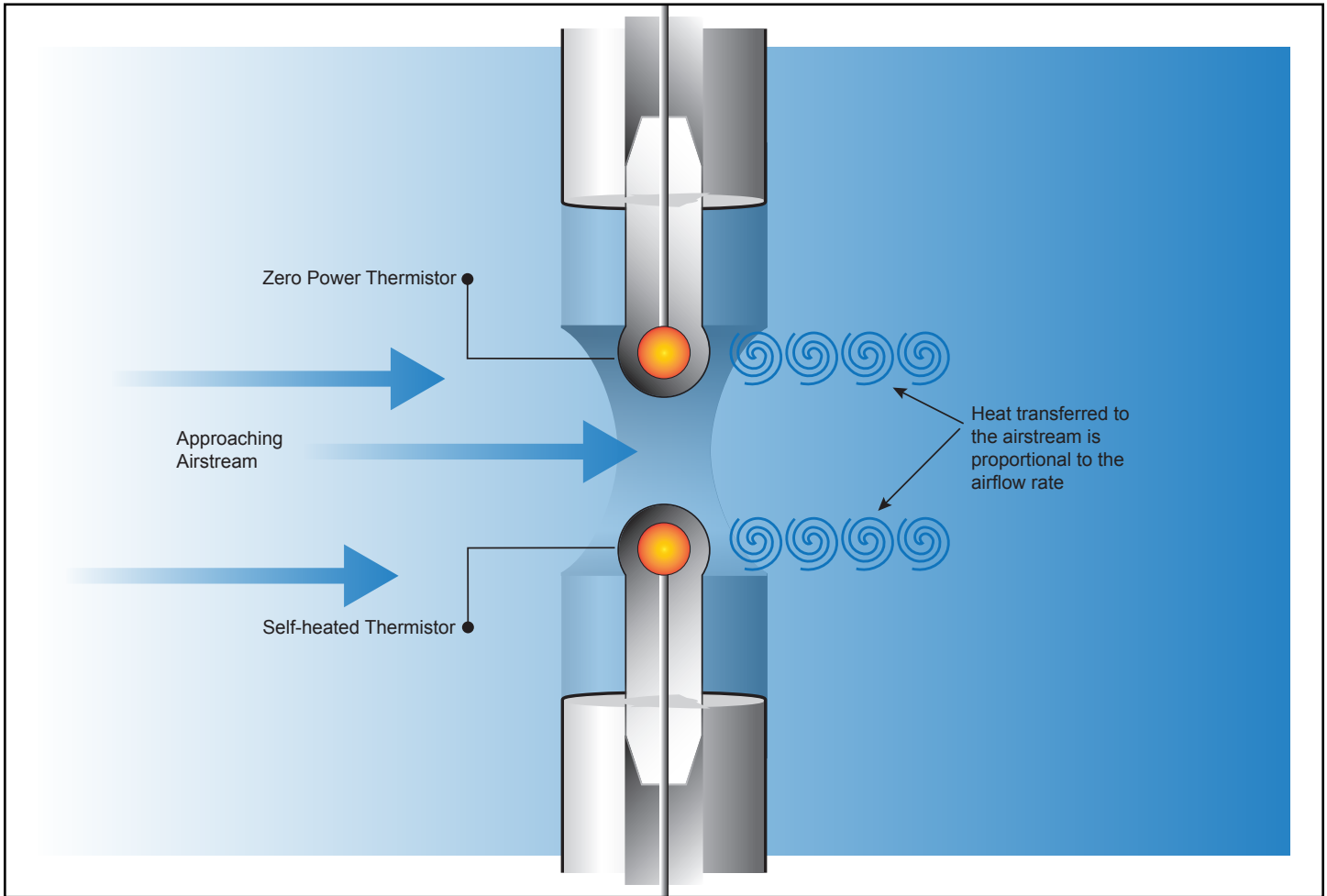

Figure 111: Bead-in-Glass Thermistor Probe



Connecting to MicroTech Unit Controllers

Wiring

1. Connect analog control wires from the MicroTech Unit Controller to the outdoor air monitor controller.
 - a. MicroTech unit controller (X4 on the EXP-A) to the controller's analog output terminal 1.
 - b. MicroTech unit controller (M on the EXP-A) to the controller's analog output terminal COM.
2. Power Wires (24 VAC) to the outdoor air monitor controller.
 - a. 24VAC from the unit control panel to the controller terminals L1 and L2.

Outdoor air monitor controller settings

1. Set Controller SW1 switch to VDC.
2. Set power switch to ON.

Outdoor air monitor controller configuration/set up

(See the unit controller manual for navigating the Controller keypad)

1. Set LCD1 U/M to "CFM"
2. Set AR1 (see Table 31)
3. Set OUT1 U/M =CFM
4. Set OUT1 =0-10V
5. Set FSI (see Table 31)

Table 31: Settings by Cabinet Size

Model	Cabinet	Area sq.ft. (AR1)	Full scale output CFM (FS1)
03-06	A	2.25	2,400
07-17	B	4.5	6,000
16-31	C	10.25	11,000

Figure 112: Outdoor Air Monitor Controller

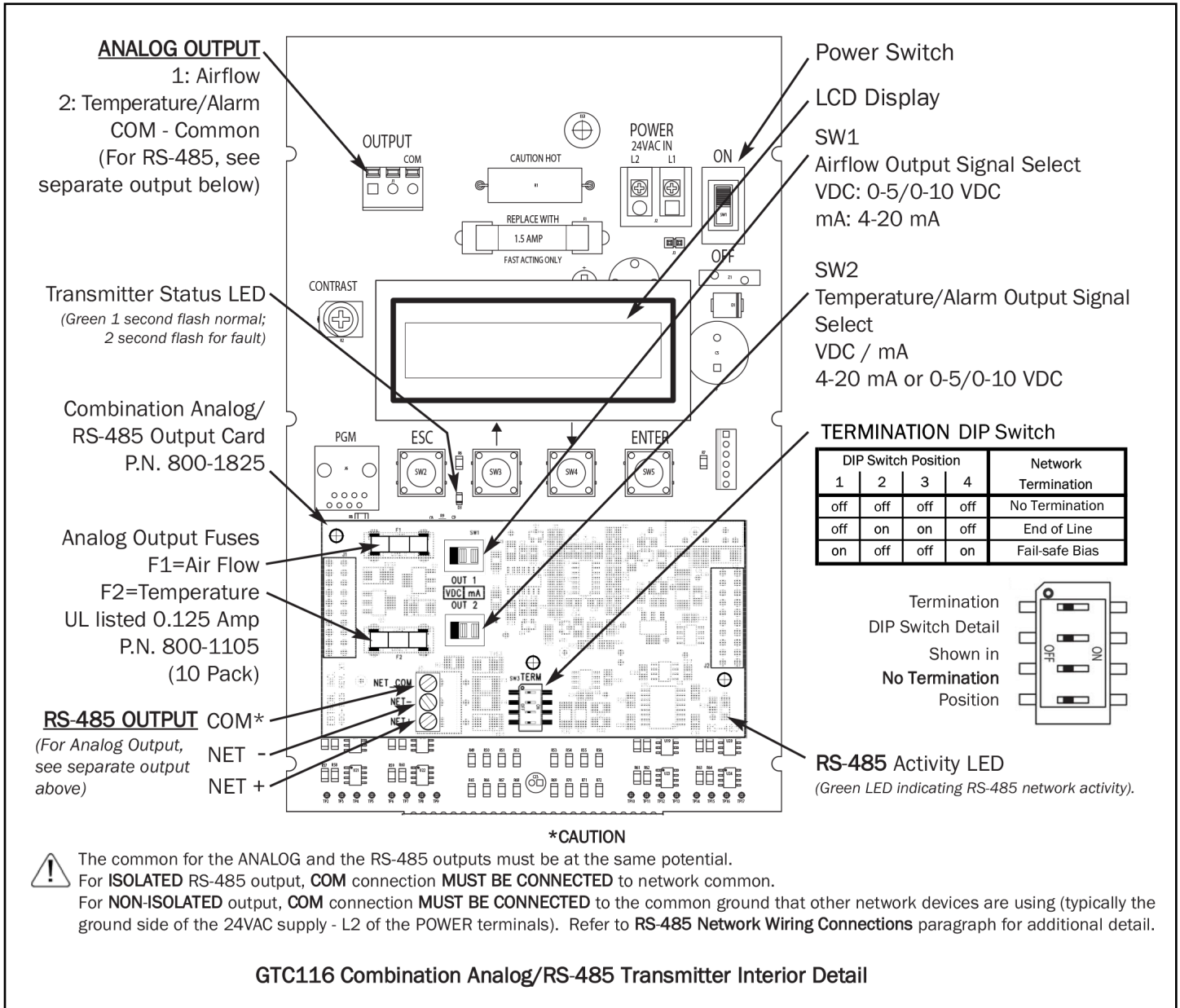

Figure 113: Transmitter Detail

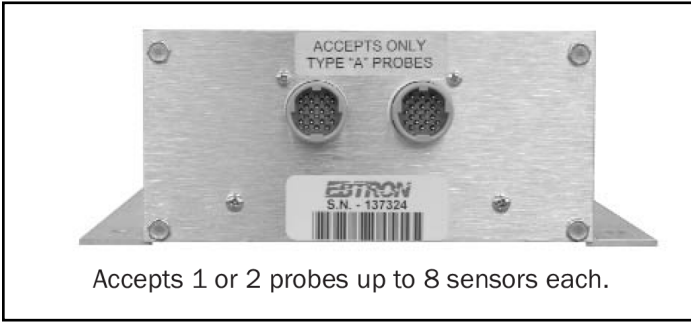

Figure 114: Connector Detail

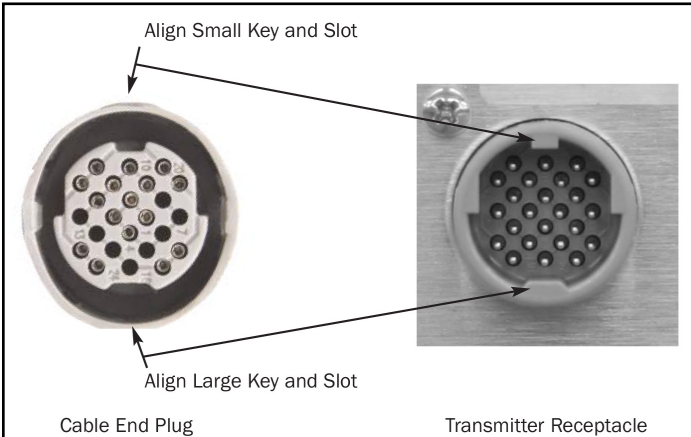
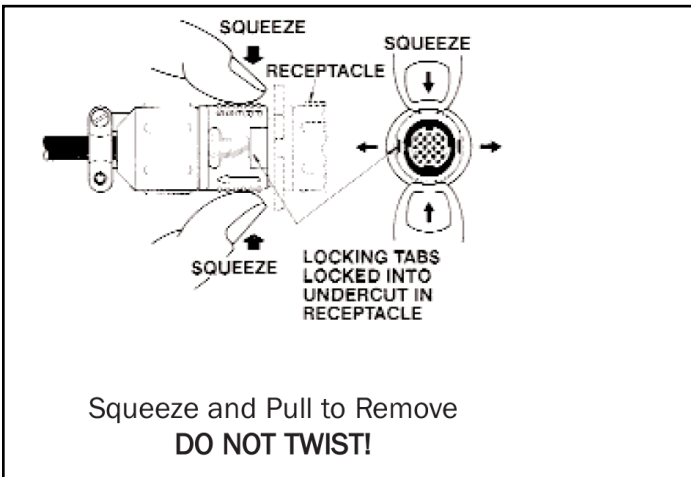

Figure 115: Connector Removal Diagram



Changing Standard Units

The transmitter is provided with the system of units set to IP (imperial). To change to SI (metric), simultaneously press and release the “UP” and “DOWN” arrow buttons during normal operation. “IP/SI UNITS” will be indicated on the LCD display. Press “ENTER” three times and use the “UP” and “DOWN” arrow buttons until the system of units desired is indicated. Press the “ENTER” button to select changes then press “ESC” twice to return to the normal operating mode. See the unit controller manual for details.

LCD Display Notifications

Following a brief initialization at power up, the LCD display automatically displays airflow and temperature as all upper case (caps) characters. The display provides additional information on system status and alarm conditions as follows:

Last LCD Character Shown in Lower Case (Probe Malfunction)

If the last character of the flow rate units on the LCD display is lower case (for example Fpm or CFm), this indicates that an improper/malfunctioning probe is connected to the transmitter.

All LCD Characters Shown in Lower Case

When all characters of the flow rate units are displayed in lower case (for example cfm) the transmitter is operating in the Field Calibration Wizard mode. Daikin Applied users do not need to use this function.

LCD Blinks ** LOW ALARM **, ** HIGH ALARM ** or ** TRBL ALARM**

The LCD will alternately flash to indicate an active alarm condition for the type of alarm that has been set. The LCD displays airflow/temperature readings between the alarm notifications. Alarm will cease when the alarm is cleared.

Converting the Analog Output Signal from FPM to CFM (MPS to LPS for SI Units Scaling)

The transmitter is shipped from the factory with analog output “OUTPUT 1” set to indicate velocity in FPM. To automatically convert this analog velocity output to volumetric flow (CFM or LPS), simply set the *OUT1 U/M from FPM (default) to CFM in the Setup Menu (See the unit controller manual for details.). If you wish to manually convert the velocity output to volumetric flow (CFM or LPS), simply multiply the indicated output velocity (in FPM or MPS) by the free area of the air flow probe installation location (free area × 1000 for SI units when area is calculated in square meters). For -P sensors, the total free area is programmed into the probe at the factory and is printed on the probe hang-tag. For -F and -B sensor probes, determine the free area following installation in accordance with the installation guidelines.

NOTE: The full scale analog output (OUTPUT1) value is determined by the FS1 setting within the SETUP MENU.

Altitude Correction Adjustment

The Altitude Correction Adjustment allows for correction of airflow readings at the installed site altitude and more precise readings regardless on installed altitude. Refer to the SETUP MENUS for the *ALT= menu item, and set this vale to the installation altitude.

Adjusting the Digital Output Filter

The digital output filter is useful for dampening signal fluctuations resulting from transient wind gusts on outdoor air intakes or excessive turbulence generated from duct disturbances. The digital output filter range can be set between 0 (OFF) and 99%. Increasing the filter percentage limits the allowable change of the output signal. To change the amount of filtering, enter the Setup menu and set “*FILTER1={desired value}”.

WARNING

Fluctuations in the airflow output signal are normal. Laboratory research indicates that dampening true fluctuations will result in poor control and a larger dead-band of operation. Therefore, the use of the dampening filters in control devices is not recommended. Warnings indicate potentially hazardous situations, which can result in property damage, severe personal injury, or death if not avoided.

Table 32: General Troubleshooting

Problem	Possible Cause	Remedy
No LCD display indication and the green Transmitter Status LED (D3) on the main circuit board is not illuminated.	Power switch not in the "ON" position.	Move the power switch to the "ON" position.
	Improper supply voltage to the power input terminal block.	Ensure that 24VAC power is connected to L1 and L2 of the POWER terminal block and that the voltage with the power switch in the "ON" position is between 22.8 and 26.4 VAC.
	Blown fuse.	Check power wiring. Ensure that multiple devices wired on a single transformer are wired "in-phase". Replace fuse only with a 1.5 amp, fast-acting fuse after the problem has been identified and corrected.
No LCD display indication and the green Transmitter Status LED (D3) on the main circuit board is flashing.	LCD contrast too low.	Turn "Contrast" potentiometer on the main circuit board "clockwise".
The LCD display is scrambled or there is no LCD display indication after touching the switches, LCD display or circuit board.	Static electricity.	Touch an earth-grounded object, such as a duct, to discharge static electricity then reset the power. Avoid direct contact with the LCD display or circuit board.
The LCD display indicates "No Probes".	The power switch on the transmitter was moved to the "ON" position before the sensor probes were connected.	Reset 24VAC power by moving the power switch from the "ON" to "OFF" position and then back to the "ON" position.
The LCD display indicates "DiffSensor Type".	Sensor probes have been mismatched.	Transmitters must have the same sensor type connected (GP1, GF1 or GB1 sensor probes).
The LCD display indicates "Too Many Sensors".	A probe with 5 or more sensors has been connected to a 'Type B' transmitter with 4 receptacles.	Probes with 5 or more sensors are shipped with and require a 'Type A' transmitter with 2 receptacles.
The last digit of the flow rate unit is displayed as a lower case letter. (When the Field Calibration Wizard is engaged, the last character of the flow rate units is displayed as an upper case letter.	The sensor detection system has detected one or more malfunctioning or missing sensors.	Check sensor probe cable connections. If sensor probe connections look OK and match the number of sensor probes indicated on each probe's hang tag.
	A probe with 5 or more sensors has been connected to a 'Type B' transmitter with 4 receptacles.	Probes with 5 or more sensors are shipped with and require a 'Type A' transmitter with 2 receptacles.
The green Transmitter Status LED (D3) on the main circuit board is "ON" but not flashing.	The microprocessor is not running.	Reset 24VAC power by moving the power switch from the "ON" to "OFF" position and then back to the "ON" position.
The green Transmitter Status LED (D3) on the main circuit board is flashing at 1-second intervals.	No problem, normal operation.	No remedy required.
The green Transmitter Status LED (D3) on the main circuit board is flashing at 2-second intervals.	The sensor detection system has detected one or more malfunctioning or missing sensors.	Check sensor probe cable connections. If sensor probe connections look OK and match the number of sensor probes indicated on each probe's hang tag.
	A probe with 5 or more sensors has been connected to a 'Type B' transmitter with 4 receptacles.	Probes with 5 or more sensors are shipped with and require a 'Type A' transmitter with 2 receptacles.
The transmitter indicates airflow when the HVAC system is not operating.	Sensors are sensitive and can measure very low air velocities. If a reading is indicated, there is airflow present where the airflow measuring station is located.	Do not attempt to adjust zero ("offset"). Doing so will result in an error in airflow measurement. The Low Limit airflow cutoff value can be set to force the output signal to zero.

(continued)		
Problem	Possible Cause	Remedy
No output signal can be measured at the OUTPUT terminal block of the transmitter.	Output card is not securely mounted on main circuit board.	Turn the transmitter power "OFF", and then press the output card firmly onto main circuit board. Turn the transmitter power back "ON".
	Blown output fuse (output 1 and output 2 are fused and protected independently on the transmitter).	Make sure that power has not been connected to the output terminal block. Correct the problem and replace with 0.125 amp, fast acting fuse only. Make sure that the host control system is not configured for a 2-wire device (no excitation voltage should be present on the signals from the host controls). Correct the problem and replace with 0.125 amp, fast acting fuse only.
	The Low Limit airflow cutoff value is above the actual airflow reading.	Decrease the Low Limit airflow cutoff value in the Setup menu until it is below the actual airflow reading.
The output signal on the transmitter fluctuates while the flow and/or temperature readings on the LCD are steady.	Electrical interference from other devices is creating noise in the signal wires to the host control system.	The output signal wiring must be shielded. Individually ground one or more of the following points: the signal wire shield at host controls; signal wire shield at the transmitter, or L2 of the power terminal block of the transmitter.
The LCD display does not match the readings indicated by the host control system.	The scaling in the host control system is incorrect.	Compare the current configuration of the transmitter with that of the host control system. Compare the minimum and full scale settings for each output by navigating through the Setup menu.

Table 33: Transmitter Troubleshooting

Problem	Possible Cause	Remedy
The host control system is unable to communicate with the transmitter.	Output card is not securely mounted on main circuit board.	Turn the transmitter power "OFF" and press the output card firmly onto main circuit board. Turn the transmitter power back "ON".
	Network signal wiring is not properly connected to the transmitter or the host controls.	Verify that the network signal wires from the host controls are connected to the proper terminals of the OUTPUT block. On the transmitter OUTPUT terminal block, NET+ is for A, NET- is for B and COM for common.
	Network protocol is not properly set on the transmitter.	Set network protocol based on the network requirements and reset transmitter power.
	Network address is not properly set on the transmitter.	Set address based on network requirements and reset transmitter power. The address must be unique for the network.
	Network termination is not properly set on the transmitter.	Set transmitter termination based on network requirements and reset the transmitter power.
The LCD display does not match the readings indicated by the host control system.	The Area or K factor of the transmitter does not match that of the host controls.	Compare the value of the Area or K factor of the transmitter with that of the host control system and make adjustments to ensure a match.
The returned value for airflow is zero when airflow is indicated on the LCD display of the transmitter.	The Low Limit airflow cutoff value is above the actual airflow reading.	Decrease the Low Limit airflow cutoff value in the Setup menu until it is below the actual airflow reading.
The status point from the transmitter has a Trouble value.	The sensor detection system has detected one or more malfunctioning or missing sensors.	Check sensor probe cable connections. If sensor probe connections look OK and match the number of sensor probes indicated on each probe's hang tag.
	A probe with 5 or more sensors has been connected to a 'Type B' transmitter with 4 receptacles.	Probes with 5 or more sensors are shipped with and require a 'Type A' transmitter with 2 receptacles.
There is no value for the differential pressure point	Differential pressure is only available from transmitters that have a Bi-directional Bleed Airflow Sensors connected.	If a differential pressure measurement is required, contact your local Daikin Applied Representative about a Bi-directional Bleed Airflow Sensor.

Figure 116: Optional Outdoor Air Monitor – Changing the Units

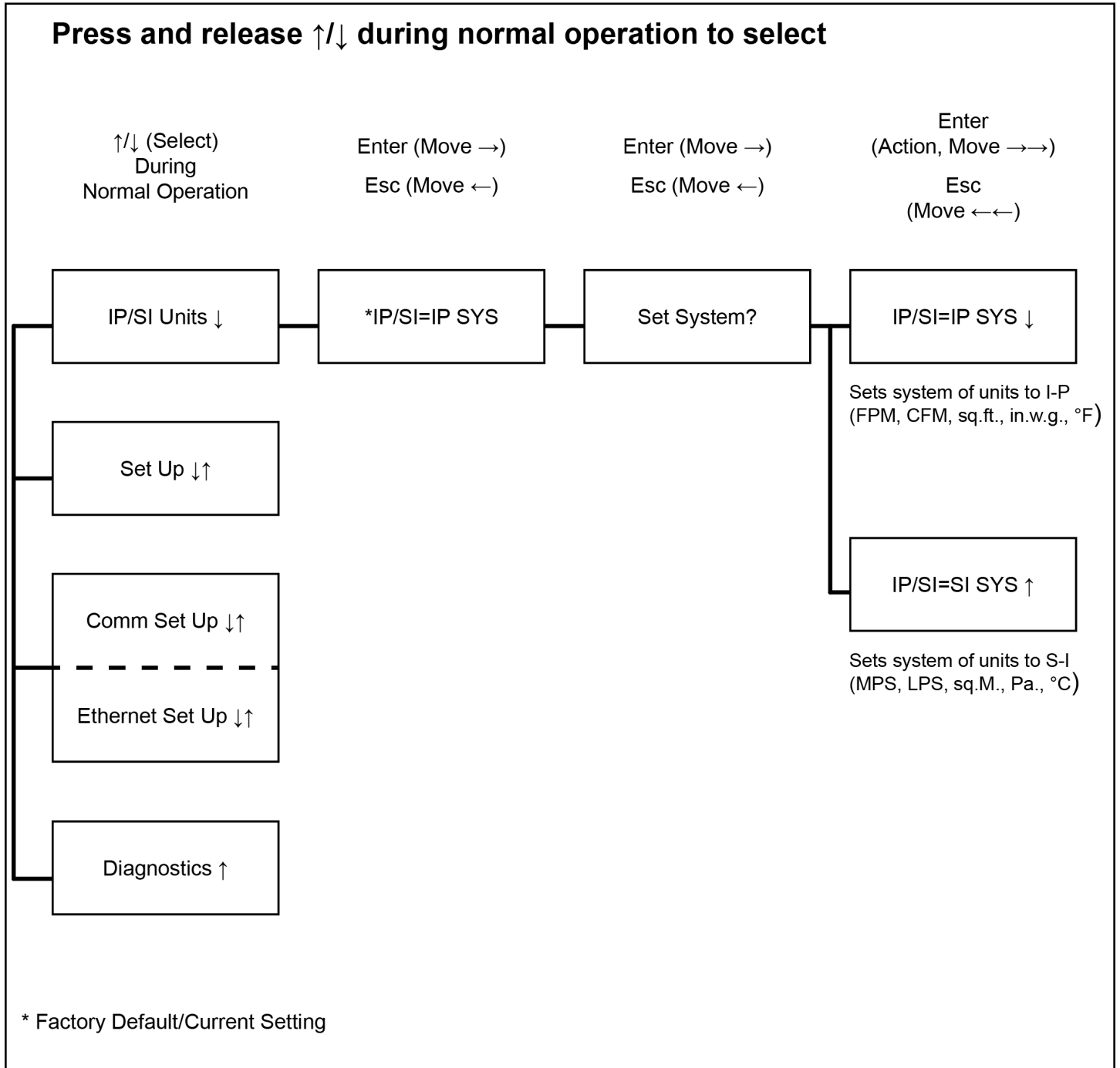
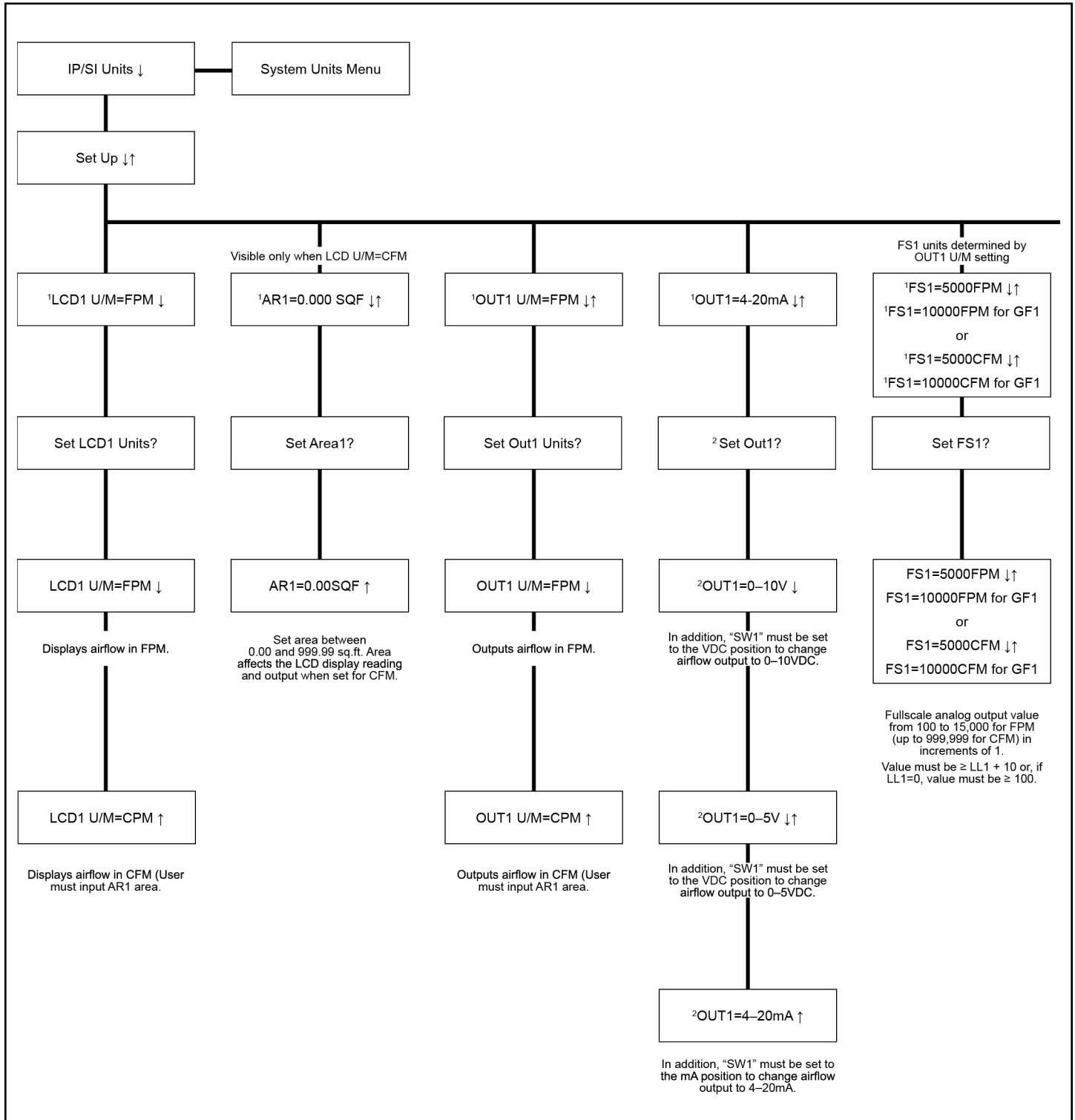
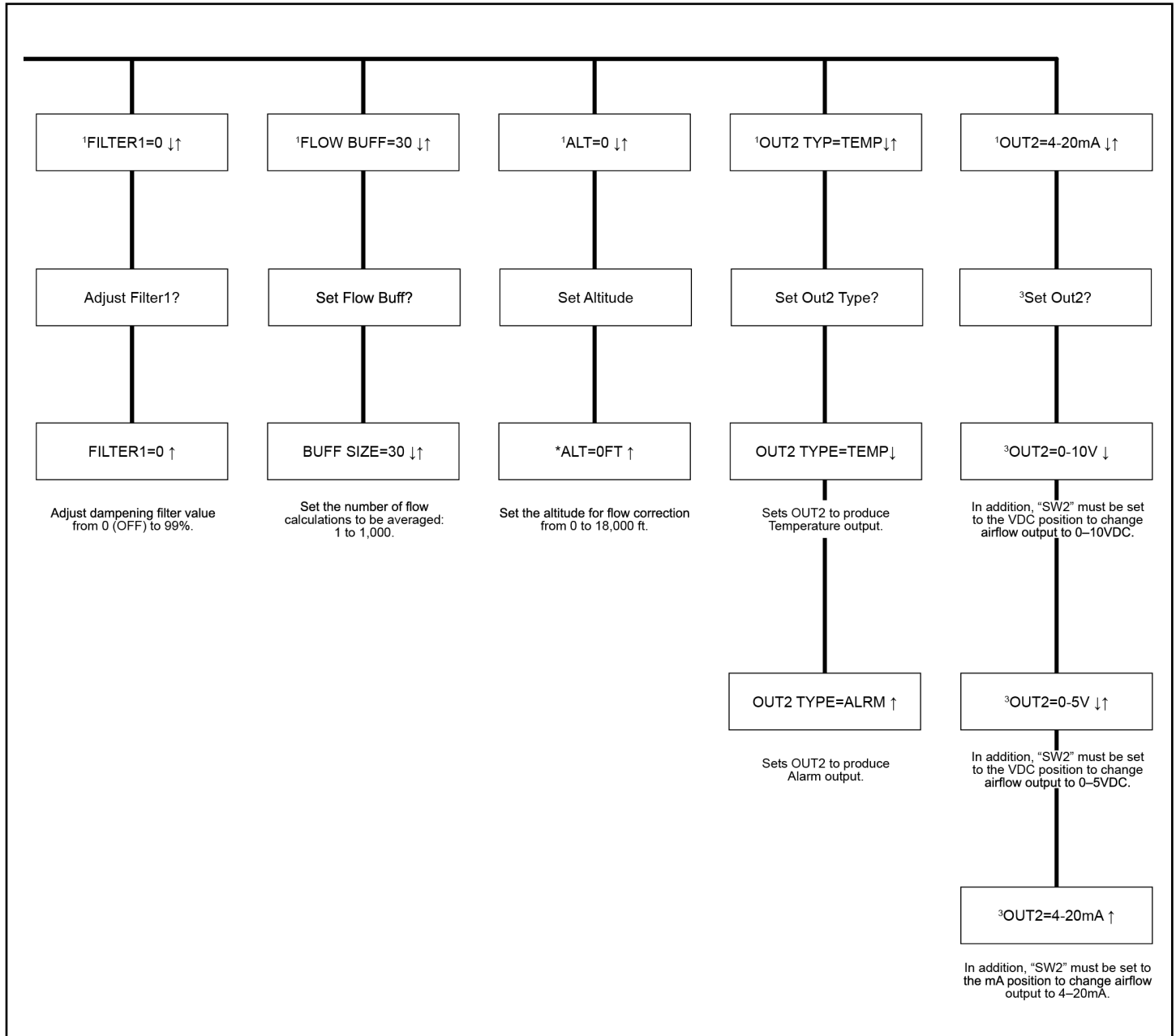

Figure 117: Optional Outdoor Air Monitor – Set Up Menu (1)



NOTE: ¹Factory default/current setting
²If a selection is made that requires SW1 to be set, the LCD displays "Set SW1 on Board".
³If a selection is made that requires SW2 to be set, the LCD displays "Set SW2 on Board".

Figure 118: Optional Outdoor Air Monitor – Set Up Menu (2)



NOTE: ¹Factory default/current setting
²If a selection is made that requires SW1 to be set, the LCD displays "Set SW1 on Board".
³If a selection is made that requires SW2 to be set, the LCD displays "Set SW2 on Board".

ECM Fans

Rebel (size 03–17) supply air fans and exhaust air fans utilize electronically commutated external motors (ECMs). ECM speed is controlled by unit mounted MicroTech unit controller, static pressure and temperature controls to reliably maintain comfort conditions.

These ECMs include locked rotor, phase failure, low voltage, high temperature and short circuit protection as well as built in soft start logic. Details are provided in the vendor’s IOM manual.

Customer design speed is programmed into the ECM based on desired CFM and ESP. Design speed can be changed as follows as long as the fan’s maximum RPM is not exceeded per Table 34.

- Go into the MicroTech unit controller keypad / display
- On the main menu, go to commission unit
- Go to SAF Set-Up [or RF/EF Set-Up] menu
- Find Max SAF [or EAF] RPM
- Enter the desired maximum RPM

Table 34: ECM Fan Sizes and Maximum Performance

Fan Diameter (mm)							
31 (310)		35 (355)		45 (450)		56 (560)	
HP	RPM	HP	RPM	HP	RPM	HP	RPM
0.5	2000	-	-	-	-	2.3	1200
1.2	2600	1.7	2400	2.4	1825	5	1590
2.1	3200	3	2870	4.3	2205	6.1	1760
3.1	3750	4.4	3300	7	2600	-	-

Addressing ECM Procedure

⚠ CAUTION

Follow all Lock-Out Tag-Out procedures to minimize risks of personal injury to yourself and/or damage to equipment during this procedure. Always wear appropriate levels of PPE governed by the hazards which are present. Terminals may vary always check unit specific wiring diagrams.

The ECM(s) communicates via Modbus RS485 twisted pair cables to the MicroTech unit controller. MicroTech can address the ECM for a supply, return-exhaust fan, outdoor fan or energy recovery wheel operation based on a unique Modbus address. A replacement ECM is shipped out from the warehouse with an address of “1” and will need to be addressed.

Addressing ECMs

1. Enter password 6363 and turn “Control Mode” to “OFF”.

NOTE: Wait for unit to shut down before moving to Step 2.

Figure 119: “Enter PW”

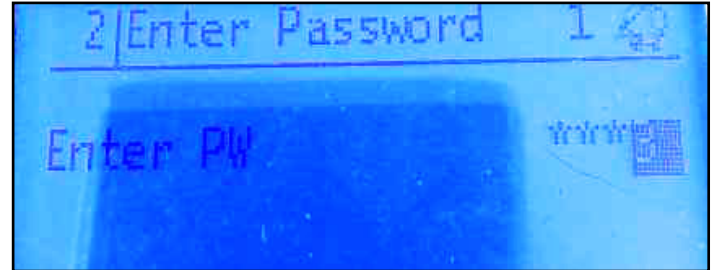

2. Shut off power to the unit and follow all Lock-Out-Tag-Out procedures.
3. Using factory provided MMPs/circuit breakers/fuses, remove power supply potential to all motors on the Modbus/RS485 trunk.
4. Verify unit wiring of Modbus/RS485 matches the unit schematic. See Figure 128 on page 115 for an example.
5. Make sure the Modbus/RS485 drains are twisted together and only landed at the controller (not at the motor).

NOTE: Ensure no drain is touching bare metal.

6. Restore power to the unit and to the motor to be addressed only.

NOTE: Ensure all motors not being addressed have power interrupted via their respective MMP/circuit breaker/fuses.

7. At the unit controller, enter password (6363) and select “About This AHU”. Ensure the last 4 digits in the app version are 6117 or greater.

NOTE: If software is prior to 6117, a software update is required.

Figure 120: Software Status

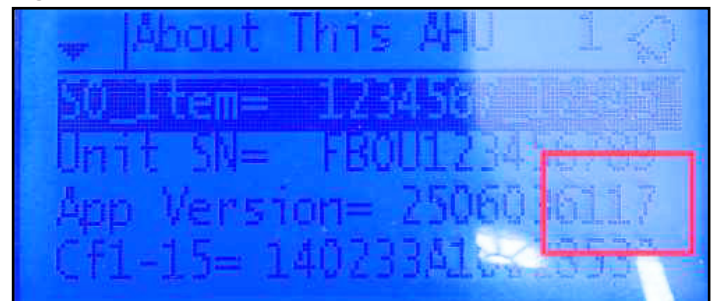

8. Press the main menu button to return to main menu.

Figure 121: Button Navigation



9. Navigate to and select "Service Menu".

Figure 122: Service Menu

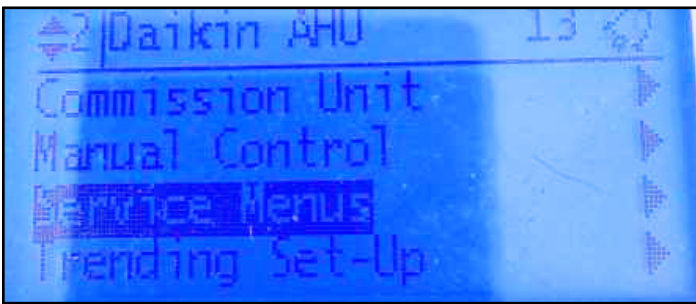

10. Navigate to and select "Modbus Status".

Figure 123: Modbus Status

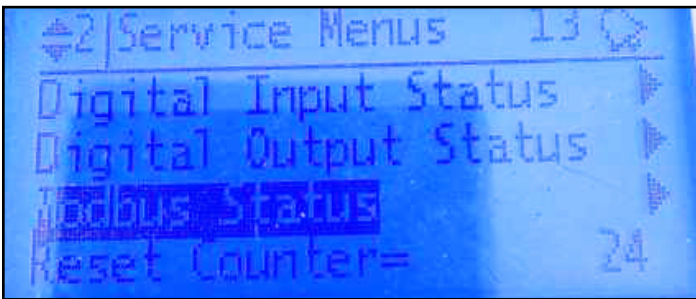

11. Confirm "DefaultECMSts" = OK

NOTE: If "DefaultECMSts" = Fault, check Modbus/RS485 wiring and ensure high voltage potential is present to the motor being addressed.

NOTE: Replacement motors are shipped with a default address.

Figure 124: Default Type

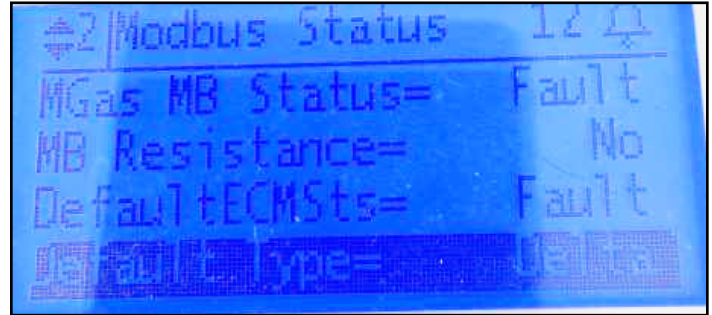

12. Navigate to and select the proper address for the value "ECM Chg To" for the motor being addressed.

NOTE: Example: Default, SFM1, SFM2, SFM3, SFM4, SFM5, SFM6, C1OF1, C1OF2.

Figure 125: ECM Chg To

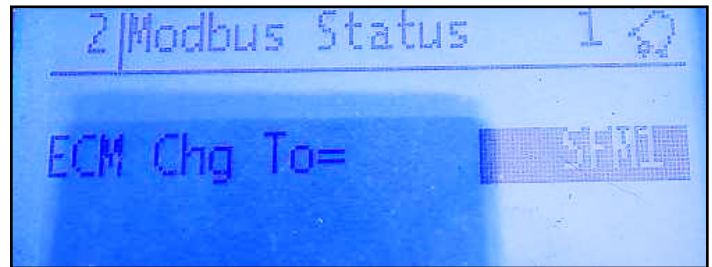

13. Navigate to and select "ECM Chg From". Confirm it is set to "Default".

Figure 126: ECM Chg From

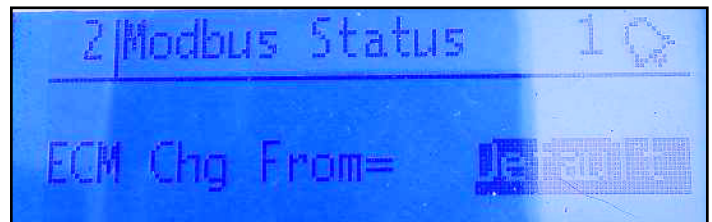

14. Navigate to and select "ECM CFG" and select "AppChg". The selection will revert to "Done" if addressing is completed.

- a. Repeat all steps to this point for any other motors that need to be addressed.

Figure 127: ECM Cfg

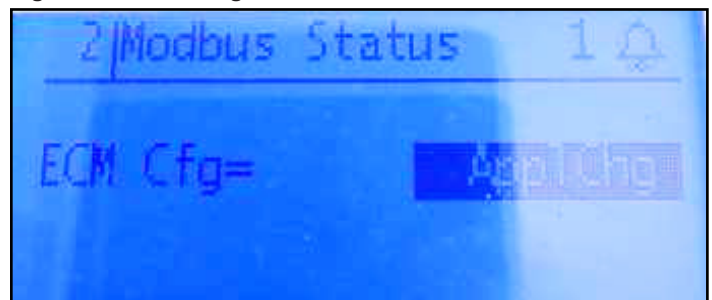

15. Turn off power to the unit.
16. Using factory provided MMP/circuit breaker/fuses, restore power supply potential to all motors on the Modbus/RS485 trunk.
17. Restore power to the unit.
18. Enter password 6363. Navigate to and select "Service Menu".
19. Navigate to and select "Modbus Status" and confirm the motor that was addressed reads "OK". Example: "SAF1 MB Status" = OK.

Figure 128: Example Schematic Diagram

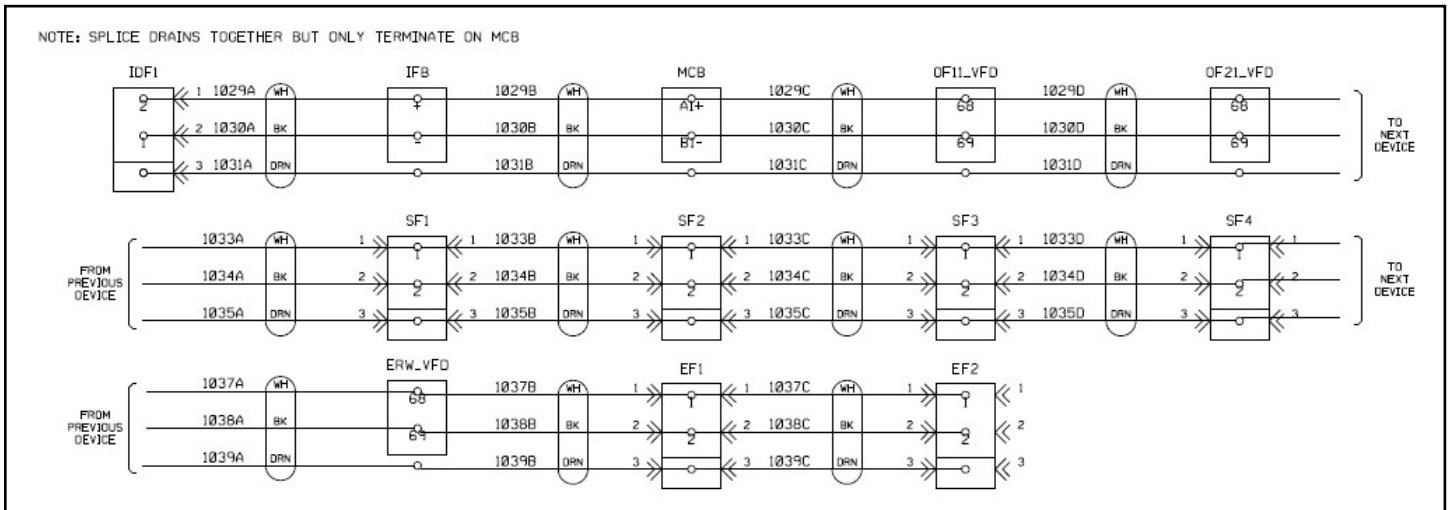

Unit Options

Economizer Enthalpy Control

The economizer can be ordered with the optional differential enthalpy control. With this option a solid-state humidity and temperature sensing device is located in the return and outdoor airstreams. These devices are labeled RAE and OAE respectively. When the outdoor enthalpy is lower than the return air enthalpy, the economizer operation will be initiated. If the outdoor air enthalpy is higher than the return air, the outdoor air damper position will be at the minimum setpoint.

External Time Scheduling

You can use external time scheduling as an alternative to (or in addition to) the MicroTech unit controller's internal scheduling function. The external timing mechanism is set up to open and close the circuit between field terminals 200 and 201. When the circuit is open, power is not supplied to binary input DI3. This is the normal condition where the controller follows the programmable internal schedule. When the circuit is closed, power is fed to DI3. The MicroTech unit controller responds by placing the unit in the occupied mode, overriding any set internal schedule.

Exhaust Fan Option

Economizer units may include exhaust fan options. For units with CAV applications, the exhaust fans can be ordered as staged control or they may be ordered with building pressure control. The building pressure control option has an inverter that runs the exhaust fan motors and is controlled by the building static pressure sensor (BSP1). The units are only available with building pressure control on VAV units.

The exhaust fan motors are permanently lubricated and do not require any additional periodic lubrication.

Figure 129: Pressure Tubing Diagram

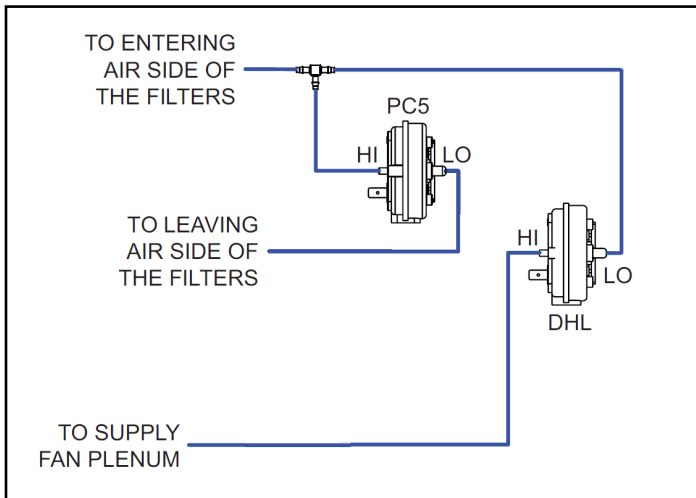

Proof-of-Airflow, Main Filter, and Final Filter Switches

Proof of air flow is accomplished through Modbus communications with the ECM/VFD for proof of air flow. The main filter switch ("PSMF" in wiring diagram) senses the pressure difference across the filter; from the entering air side of the filter to the leaving air side of the filters. The switch is factory set at 1.0" WC. When the pressure difference across the filters is sensed at this value or the pressure registered at PTMF is above the MainFiltrSpt1, the main filter alarm will appear on the MicroTech controller. Typically the dirty filter switch and the Duct High limit (DHL) are tied together with polyethylene tubing to direct the proper static pressures to the proper ports. (Figure 129). The DHL is factory set at 3.5" WC. When this differential pressure is sensed, the normally closed contacts will open on the switch, initiating the DHL alarm at the unit controller.

The unit may also have an ERW filter switch (final filter switch or "PSEW" in wiring diagram) and ERW filter transducer (final filter transducer or "PTEW" in wiring diagram). When the switch is open or the pressure registered at PTEW is above the MainFiltrSpt2 the final filter, an alarm will appear on the MicroTech controller.

Duct High Pressure Limit

The duct high pressure limit control (DHL) is provided on all VAV units. The DHL protects the duct work, terminal boxes, and the unit from over pressurization, which could be caused by, for example, tripped fire dampers or control failure.

The DHL control opens when the discharge plenum pressure rises to 3.5" WC (872 Pa). This setting should be correct for most applications and should not be adjusted.

If the DHL switch opens, digital input DI5 on the Unit Control Board will be de-energized. The MicroTech unit controller then shuts down the unit and enters the Off-Alarm state. The alarm must be manually cleared before the unit can start again. Refer to the operation manual supplied with your unit for more information on clearing alarms.

Convenience Receptacle (Field Powered)

A Ground Fault Circuit Interrupter (GFCI) convenience receptacle is provided in the main control box on all units. To use this receptacle, connect a separate field-supplied 115 V power wiring circuit to the outlet.

Convenience Receptacle (Unit Powered)

A Ground Fault Circuit Interrupter (GFCI) convenience receptacle is provided in the main control box on all units. The receptacle is powered by a factory installed and wired 120V, 20 amp power supply. The power supply is wired to the line side of the unit's main disconnect, so the receptacle is powered when the main unit disconnect is off. This option includes a GFCI receptacle, transformer, and a branch circuit disconnect. The electrical circuit is complete with primary and secondary overload protection. See [Figure 130](#) for a branch circuit diagram.

Figure 130: Unit Powered GFCI Receptacle Schematic

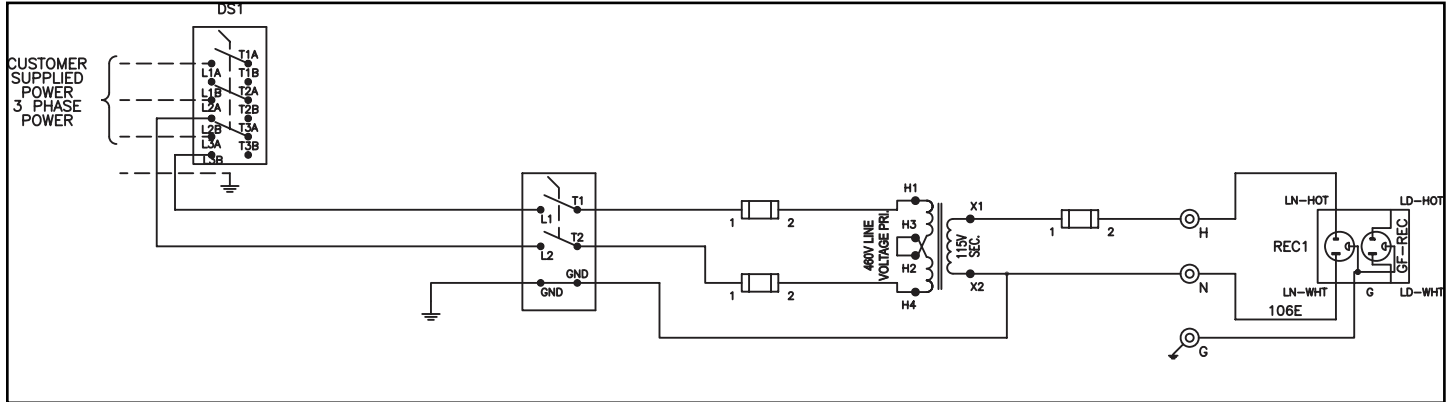

Typical Wiring Diagrams

Figure 131: Typical A Cabinet, 208V, Gas Heat Wiring Diagram (1)

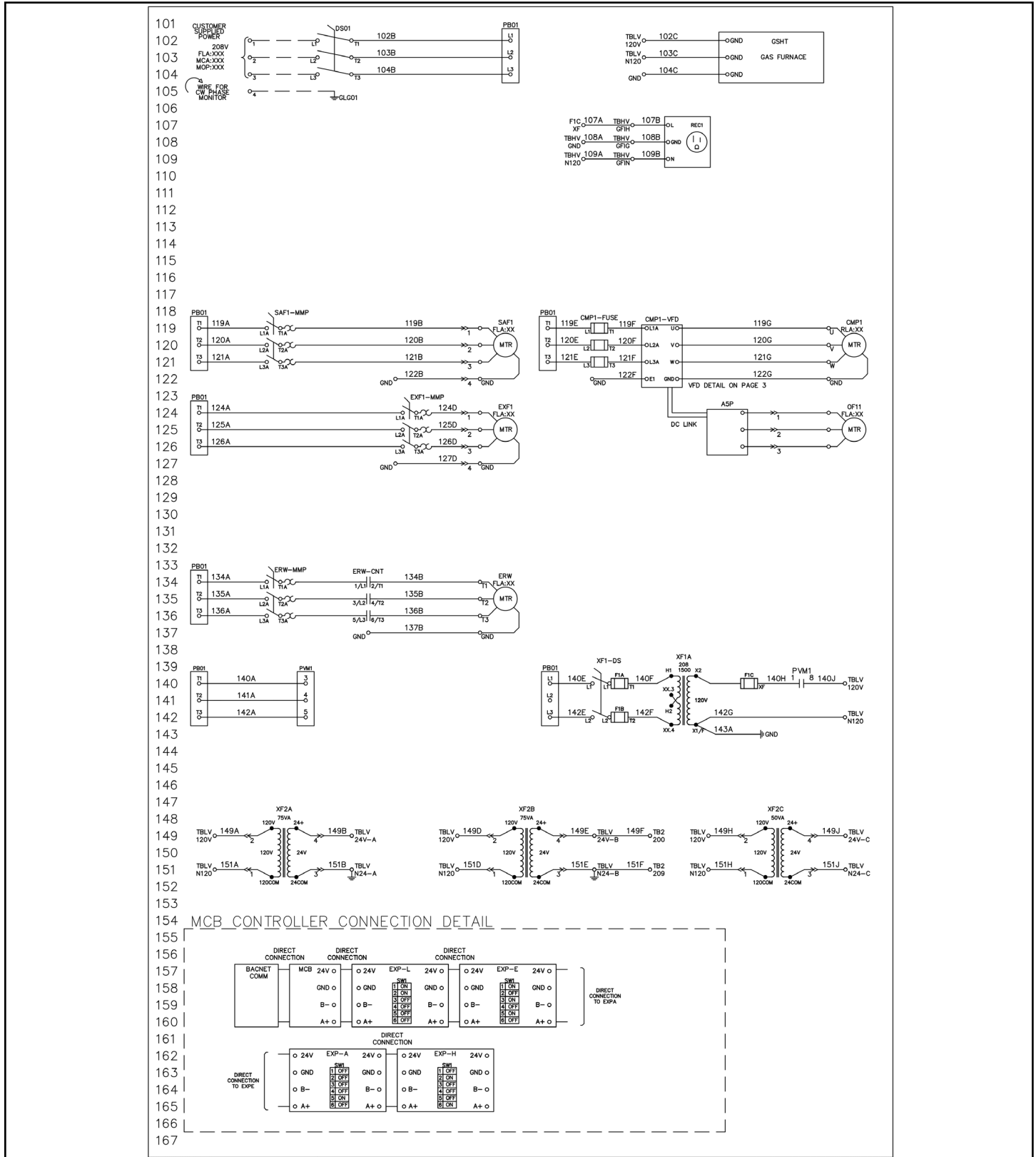

Figure 132: Typical A Cabinet, 208V, Gas Heat Wiring Diagram (2)

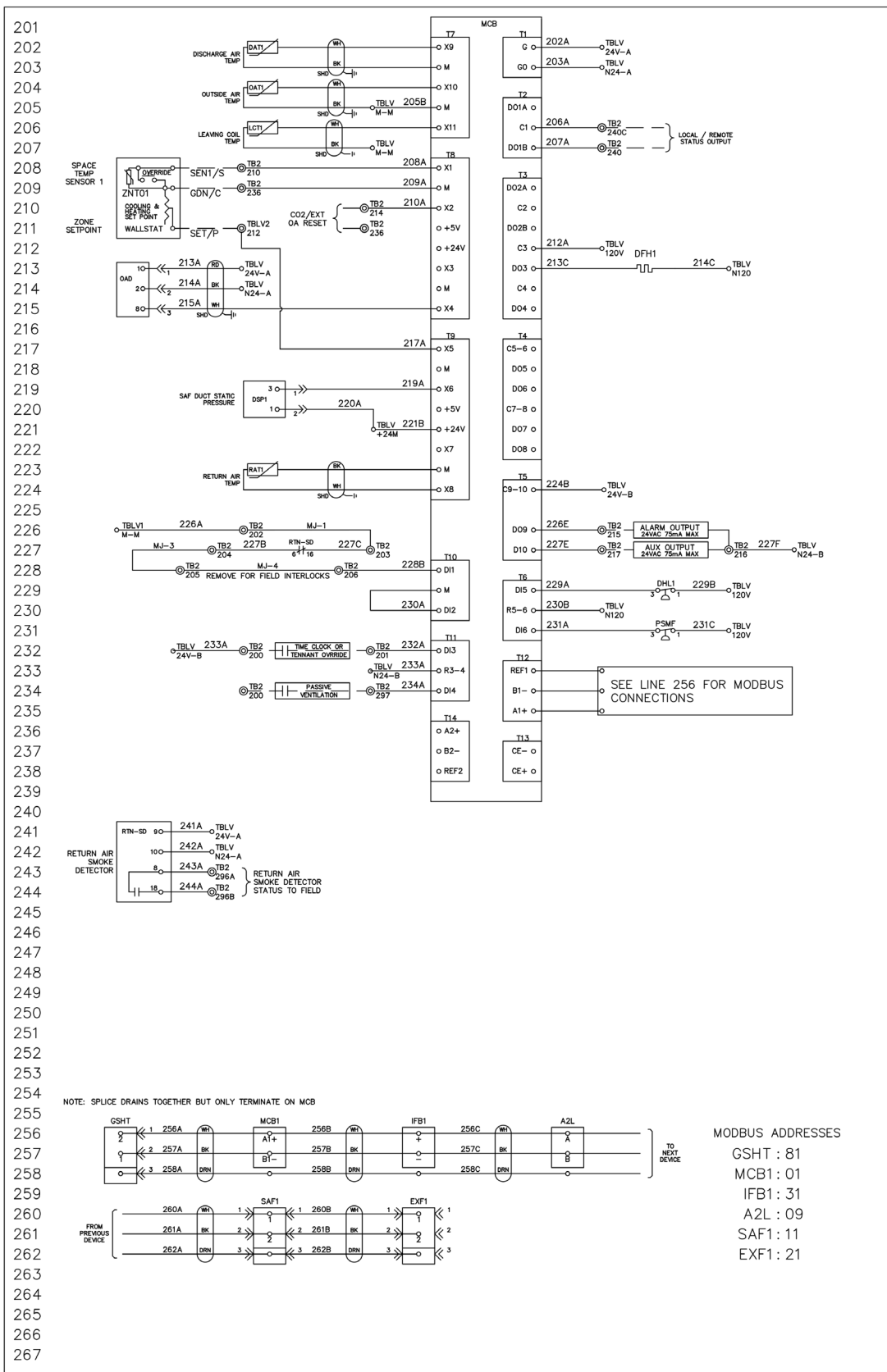

Figure 133: Typical A Cabinet, 208V, Gas Heat Wiring Diagram (3)

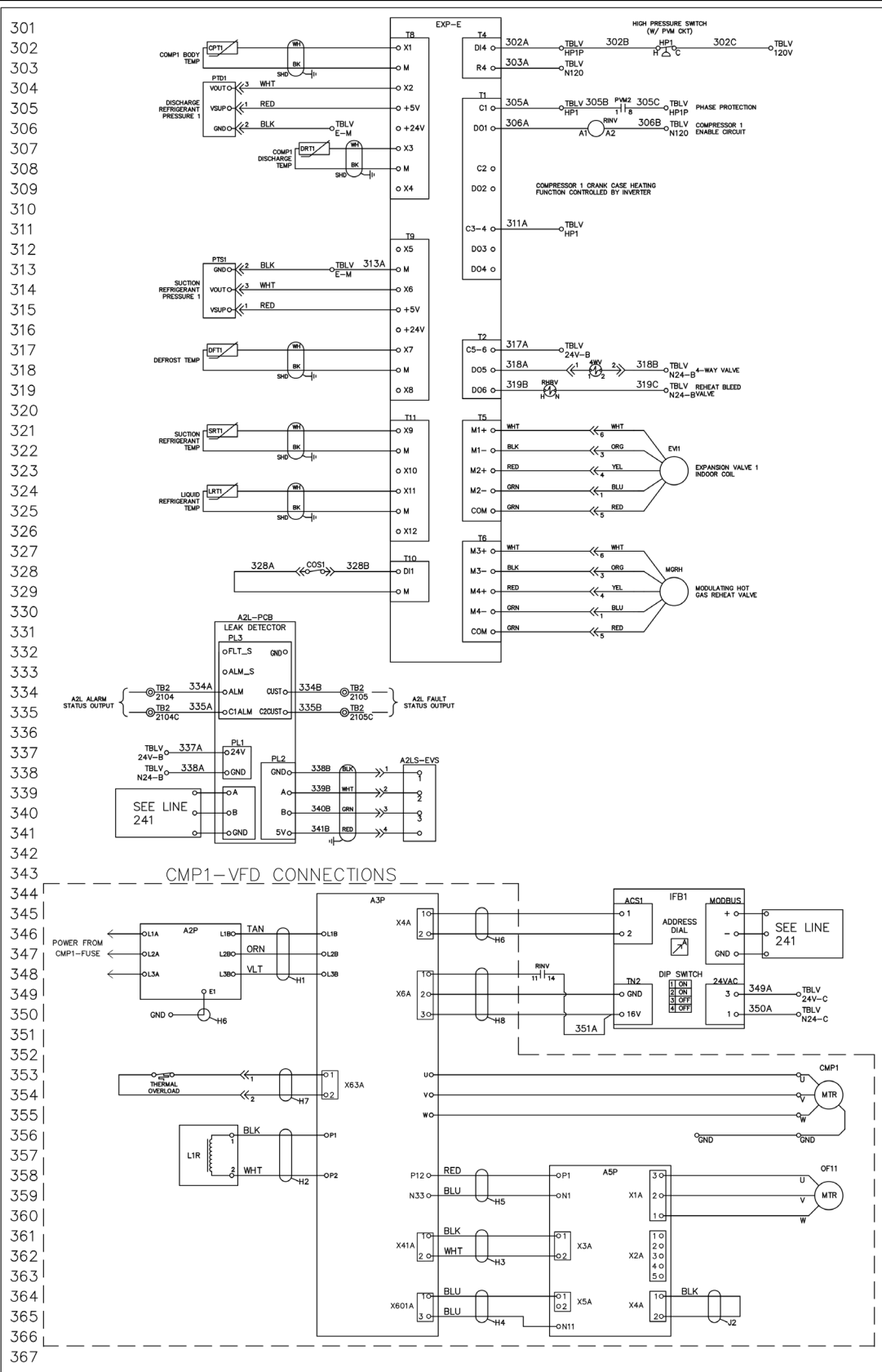

Figure 134: Typical A Cabinet, 208V, Gas Heat Wiring Diagram (4)

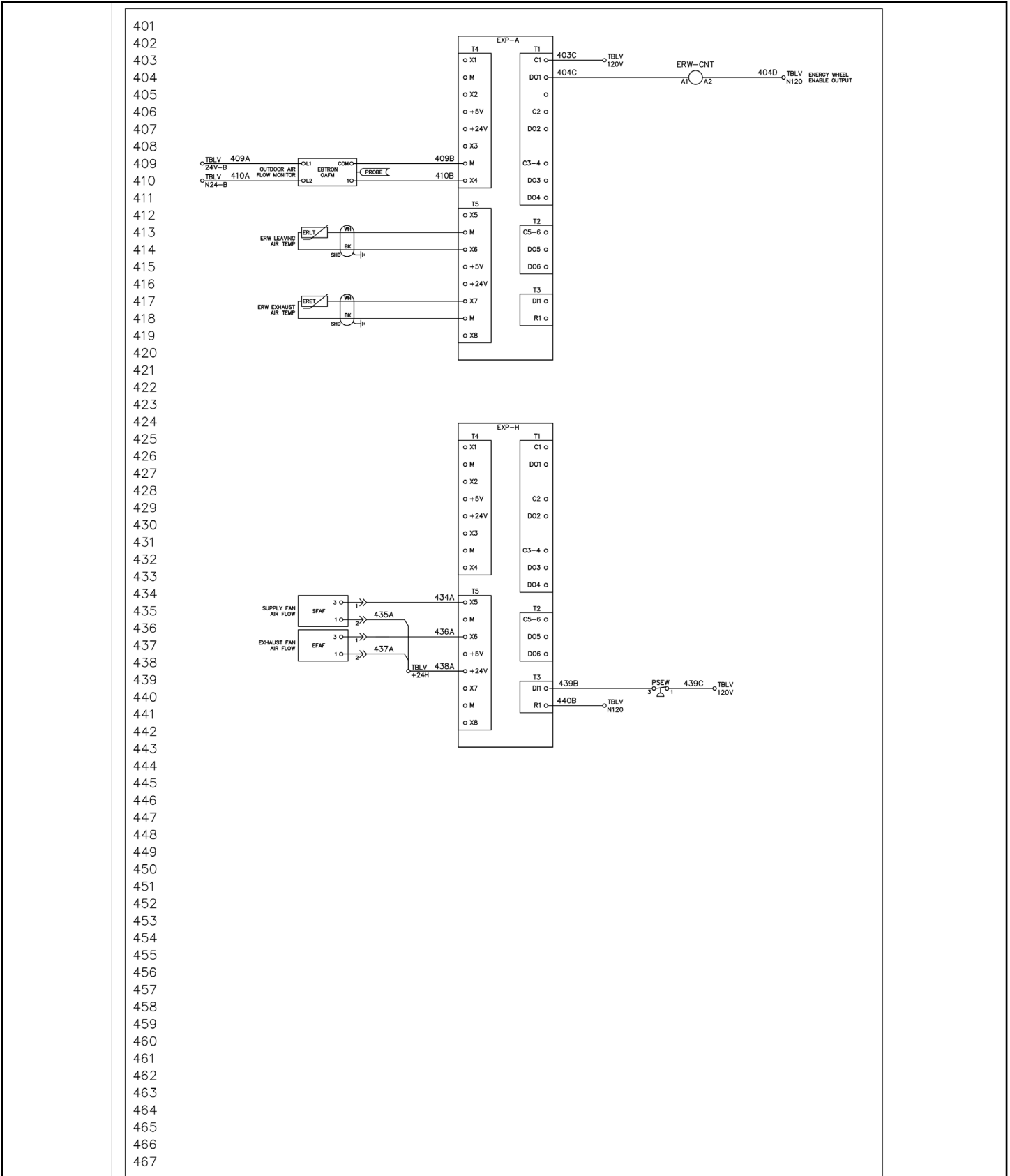

Figure 135: Typical A Cabinet, 460V, Electric Heat Wiring Diagram (1)

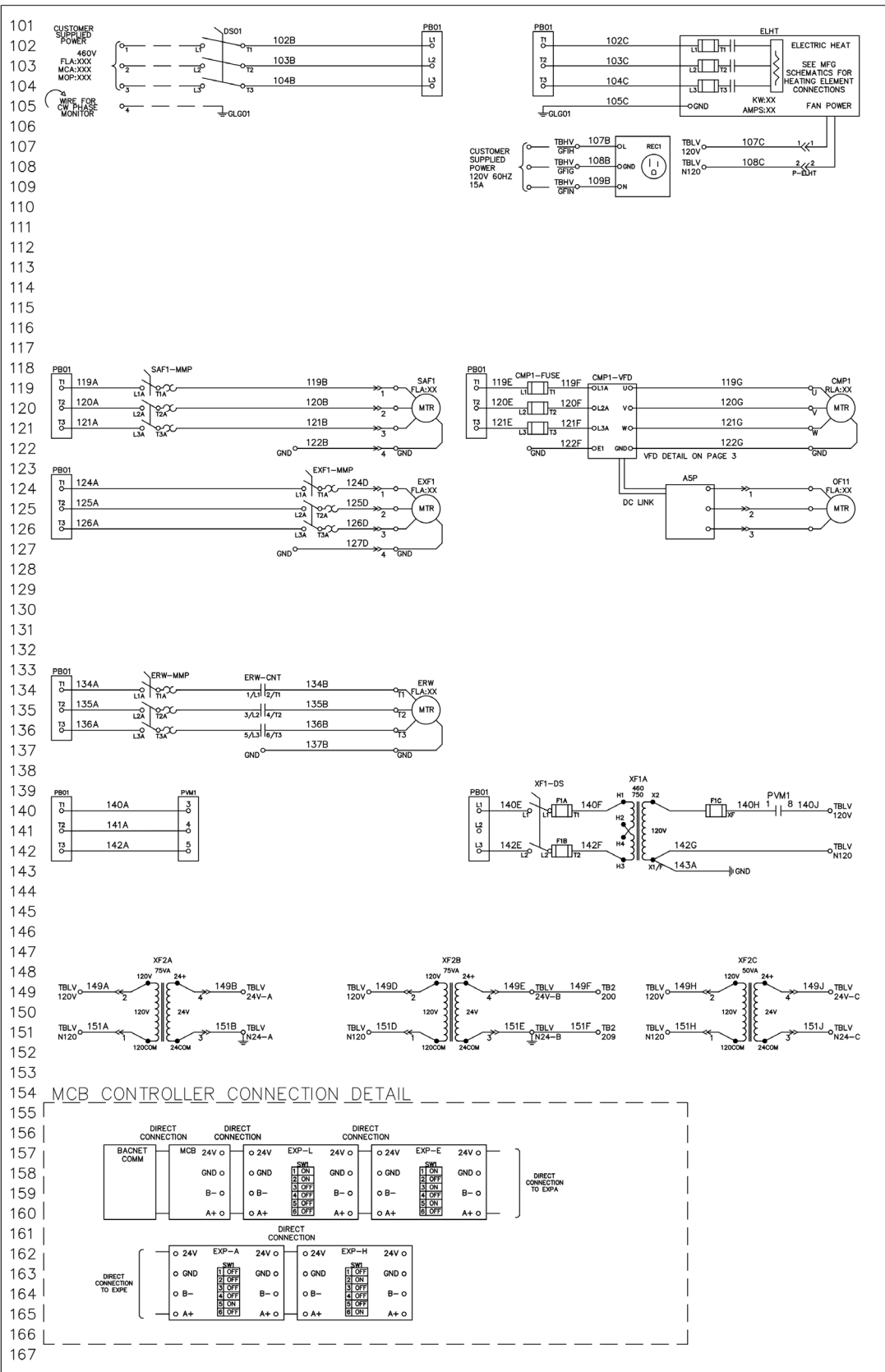

Figure 136: Typical A Cabinet, 460V, Electric Heat Wiring Diagram (2)

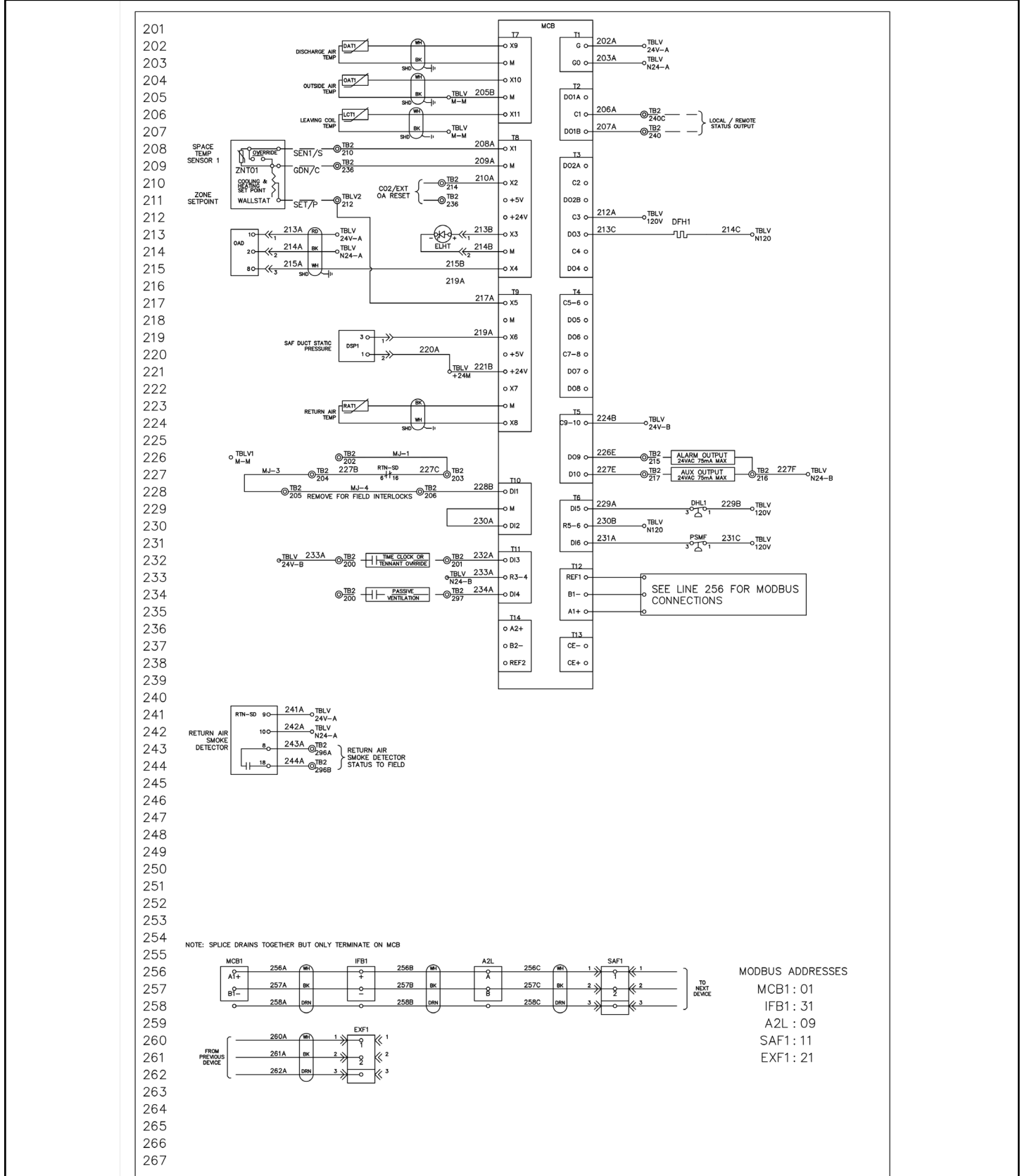

Figure 137: Typical A Cabinet, 460V, Electric Heat Wiring Diagram (3)

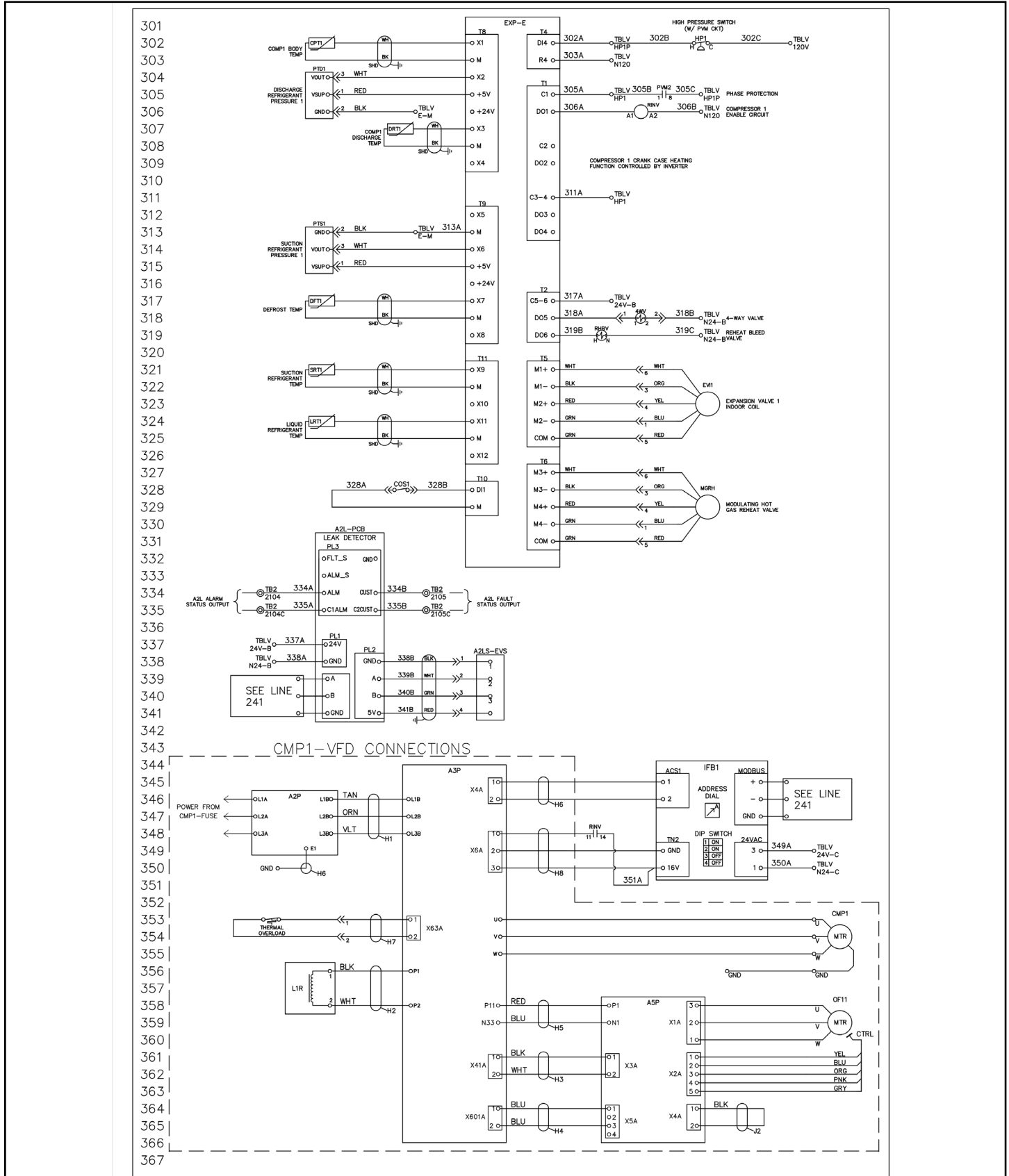

Figure 138: Typical A Cabinet, 460V, Electric Heat Wiring Diagram (4)

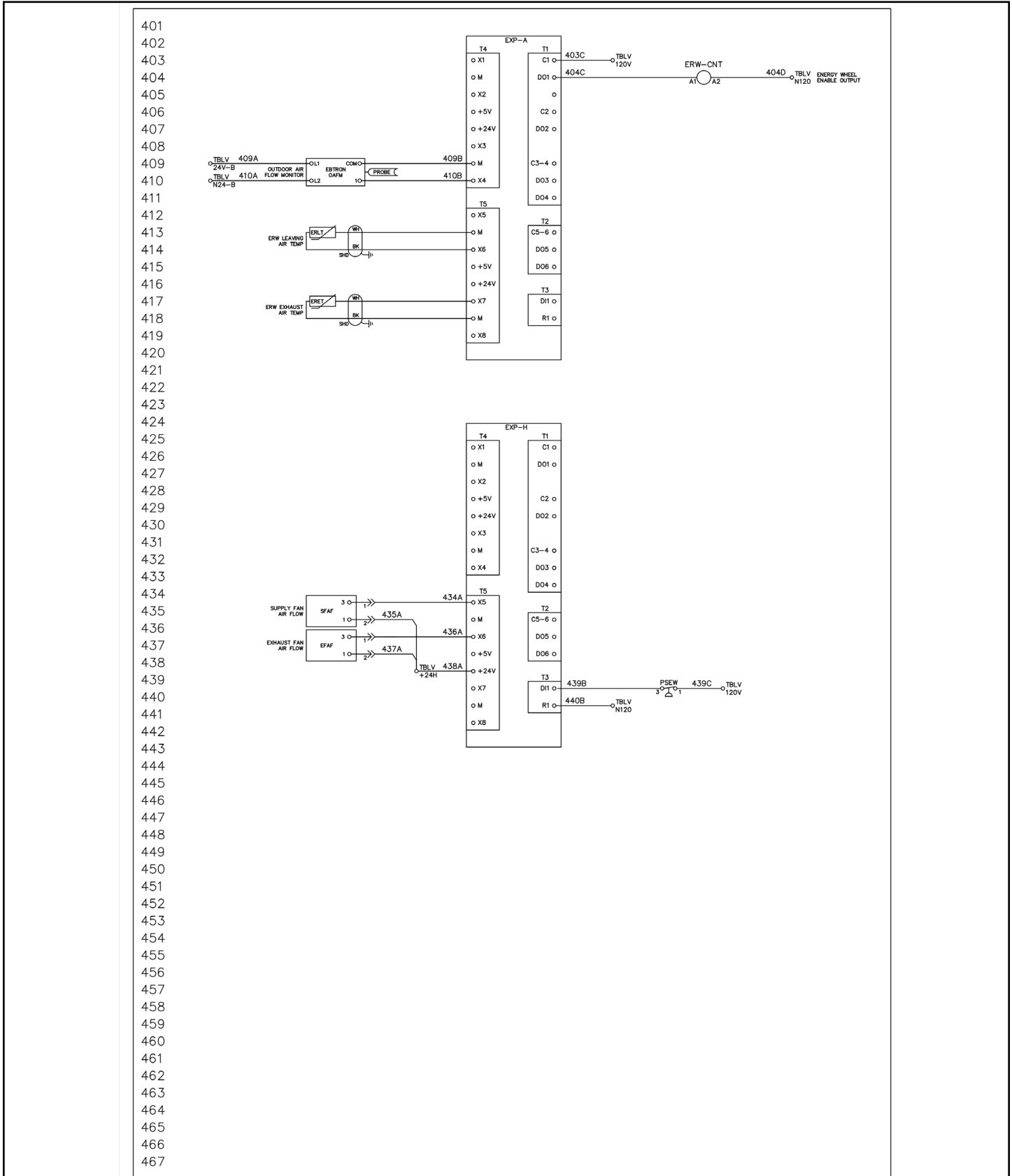

Figure 139: Typical B Cabinet, 575V, Electric Heat Wiring Diagram (1)

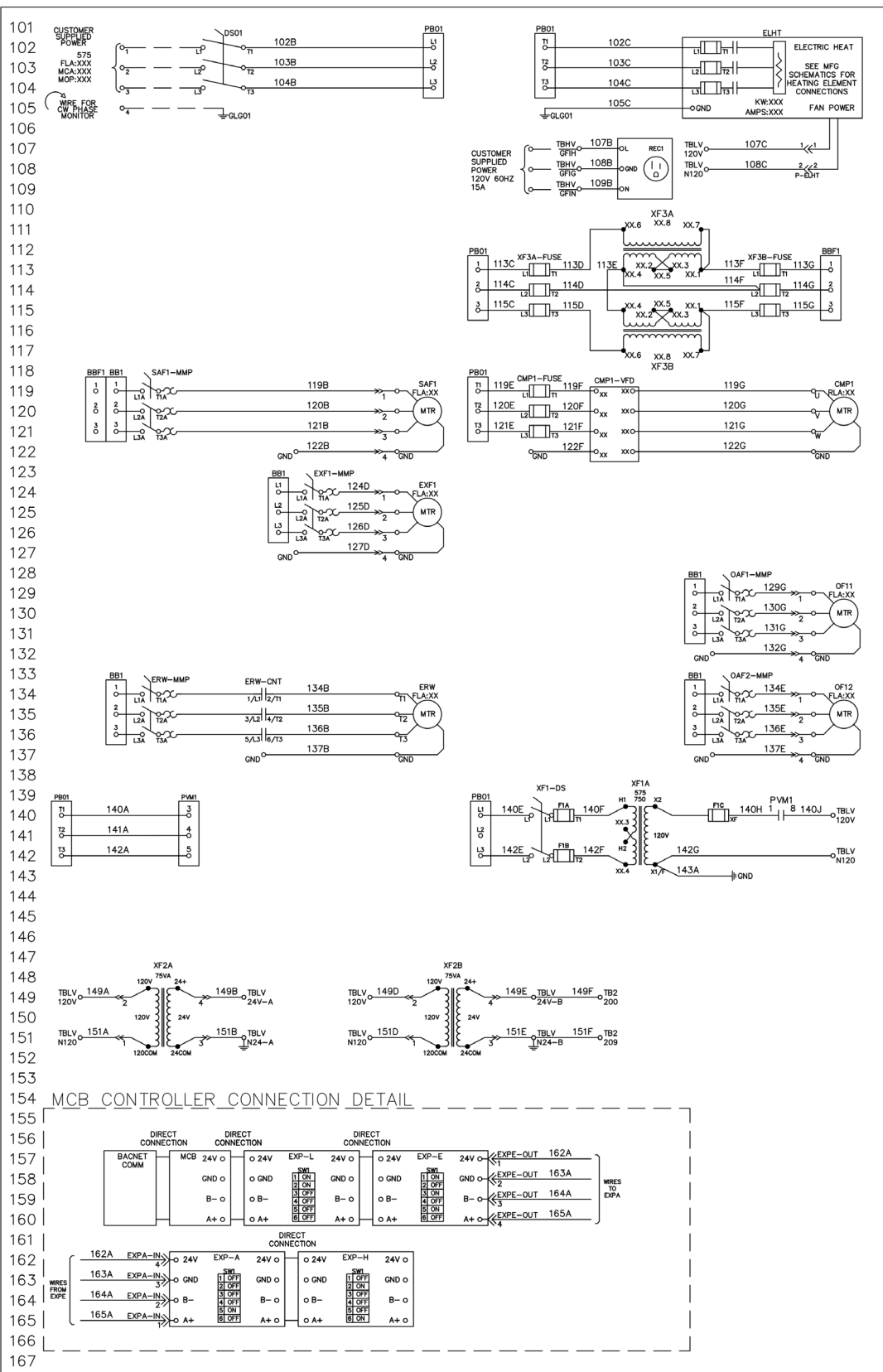

Figure 140: Typical B Cabinet, 575V, Electric Heat Wiring Diagram (2)

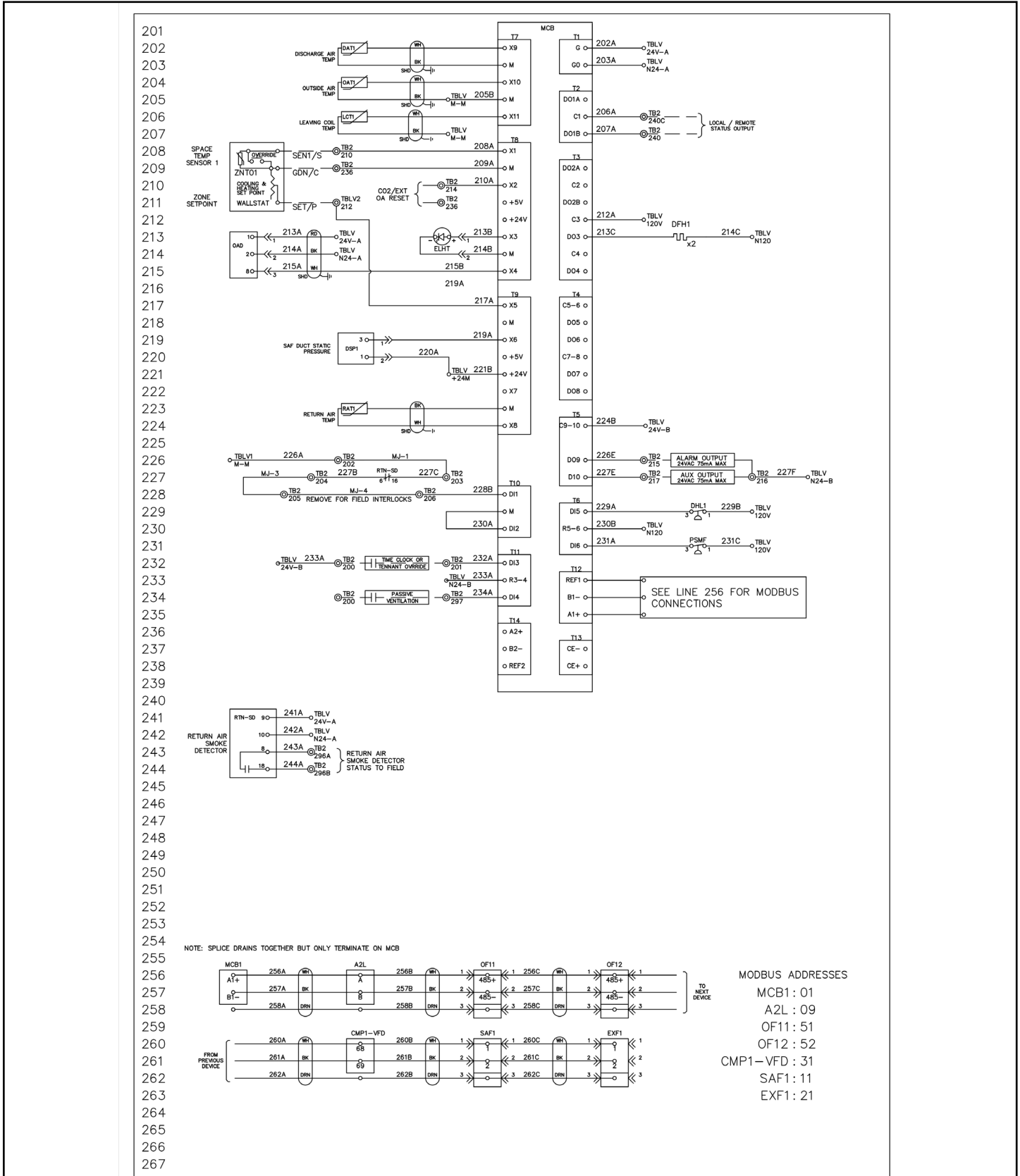

Figure 141: Typical B Cabinet, 575V, Electric Heat Wiring Diagram (3)

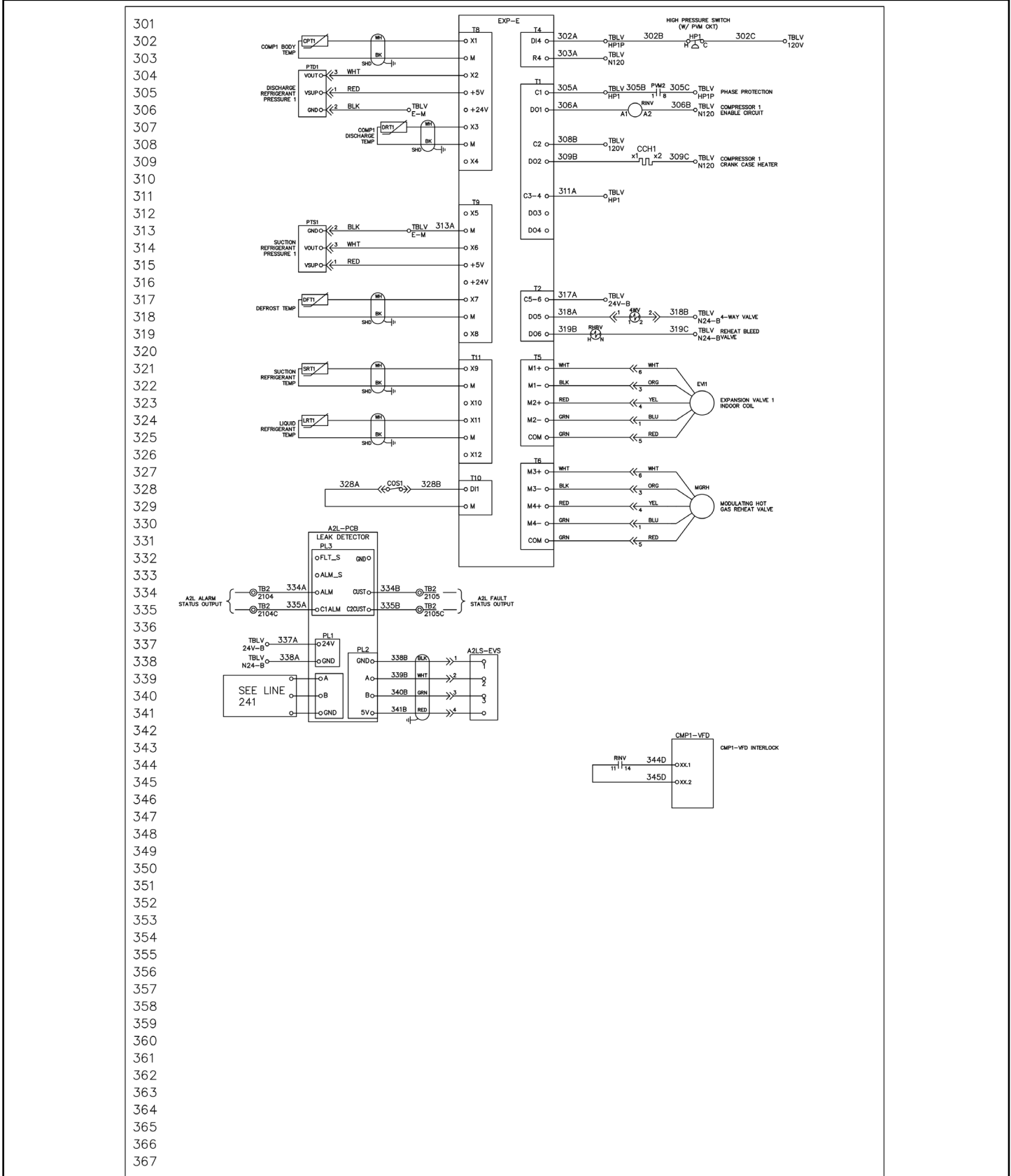

Figure 142: Typical B Cabinet, 575V, Electric Heat Wiring Diagram (4)

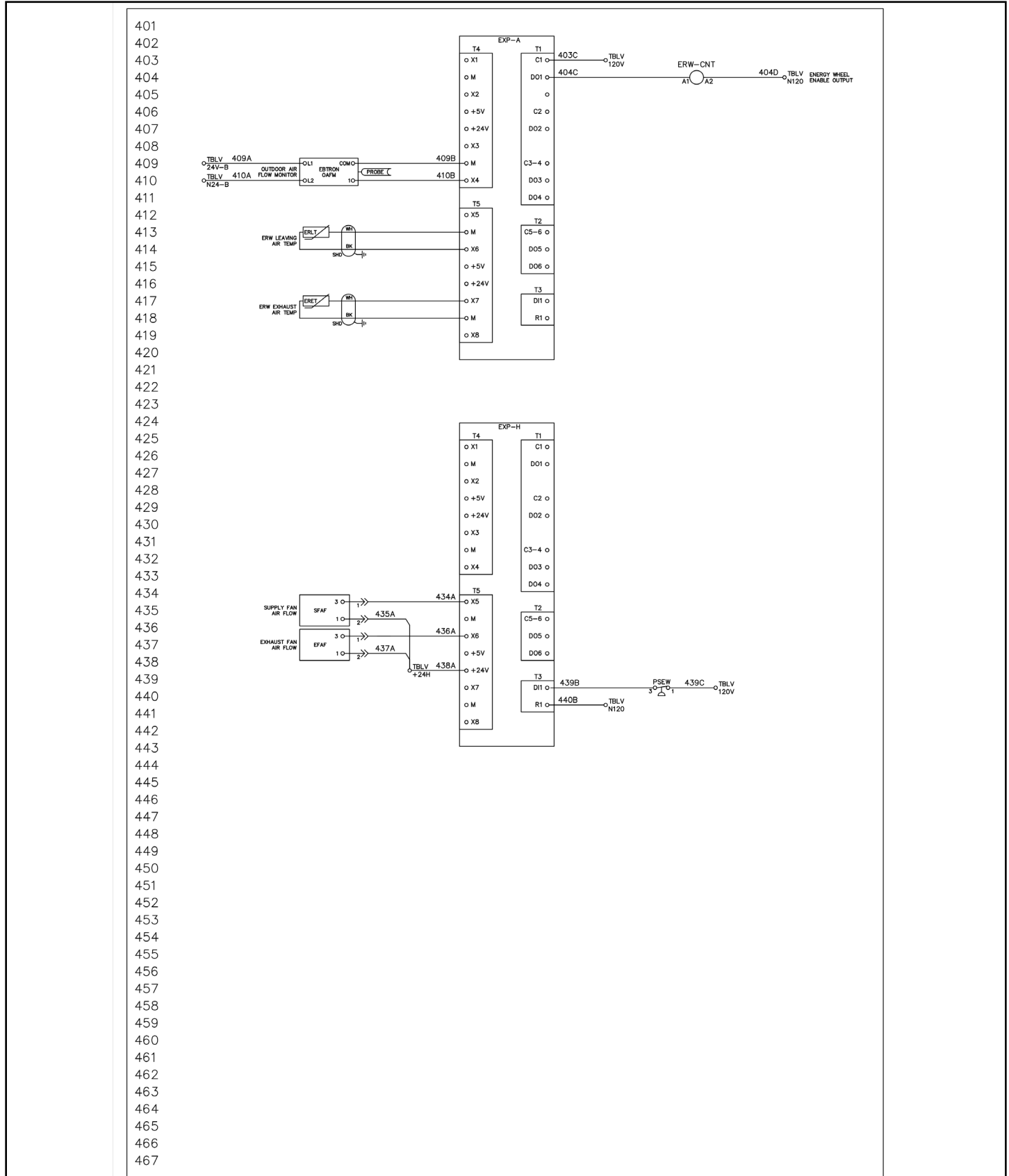

Figure 143: Typical C Cabinet, 460V, Gas Heat, Dual Disconnect Wiring Diagram (1)

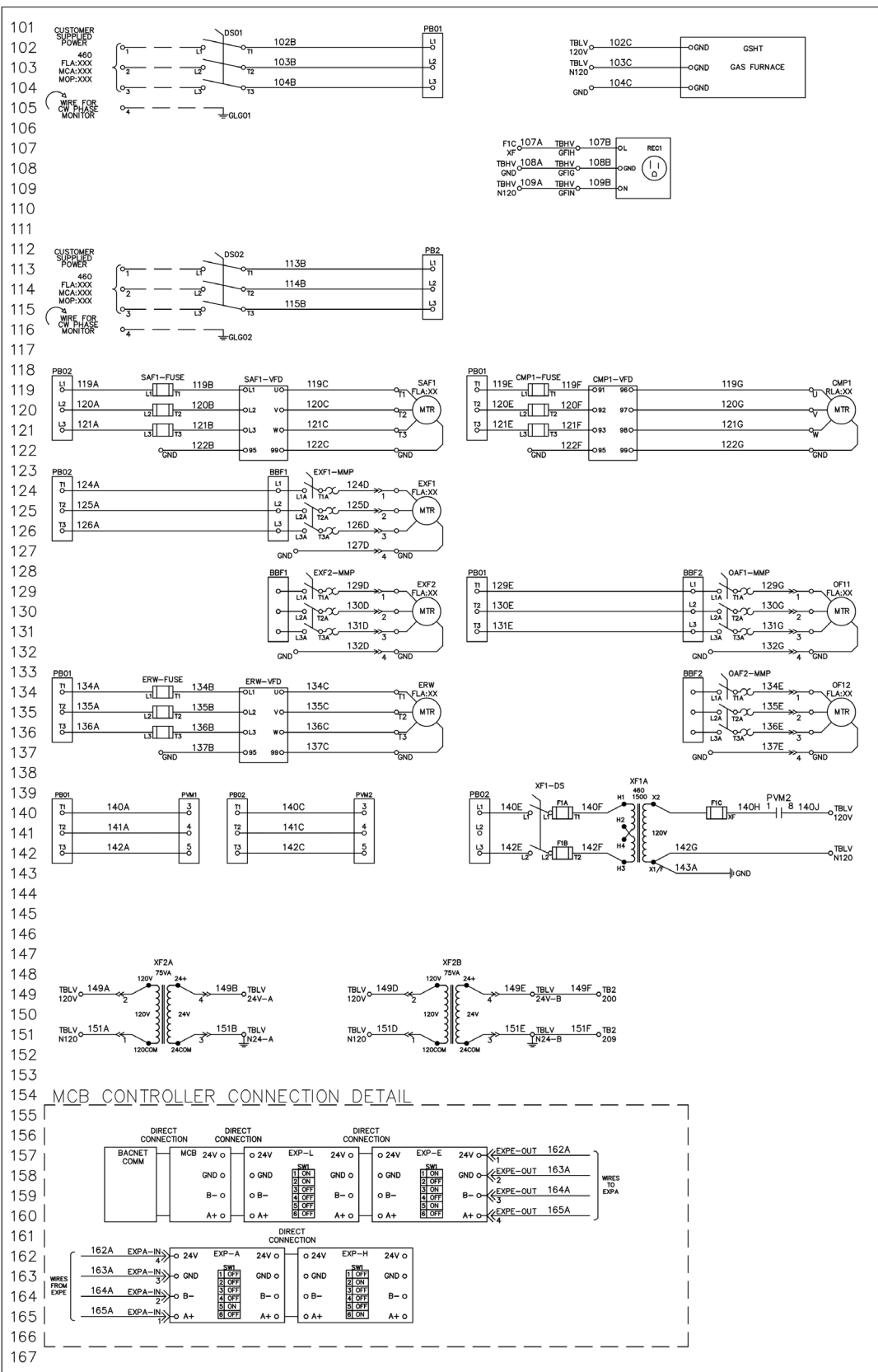

Figure 144: Typical C Cabinet, 460V, Gas Heat, Dual Disconnect Wiring Diagram (2)

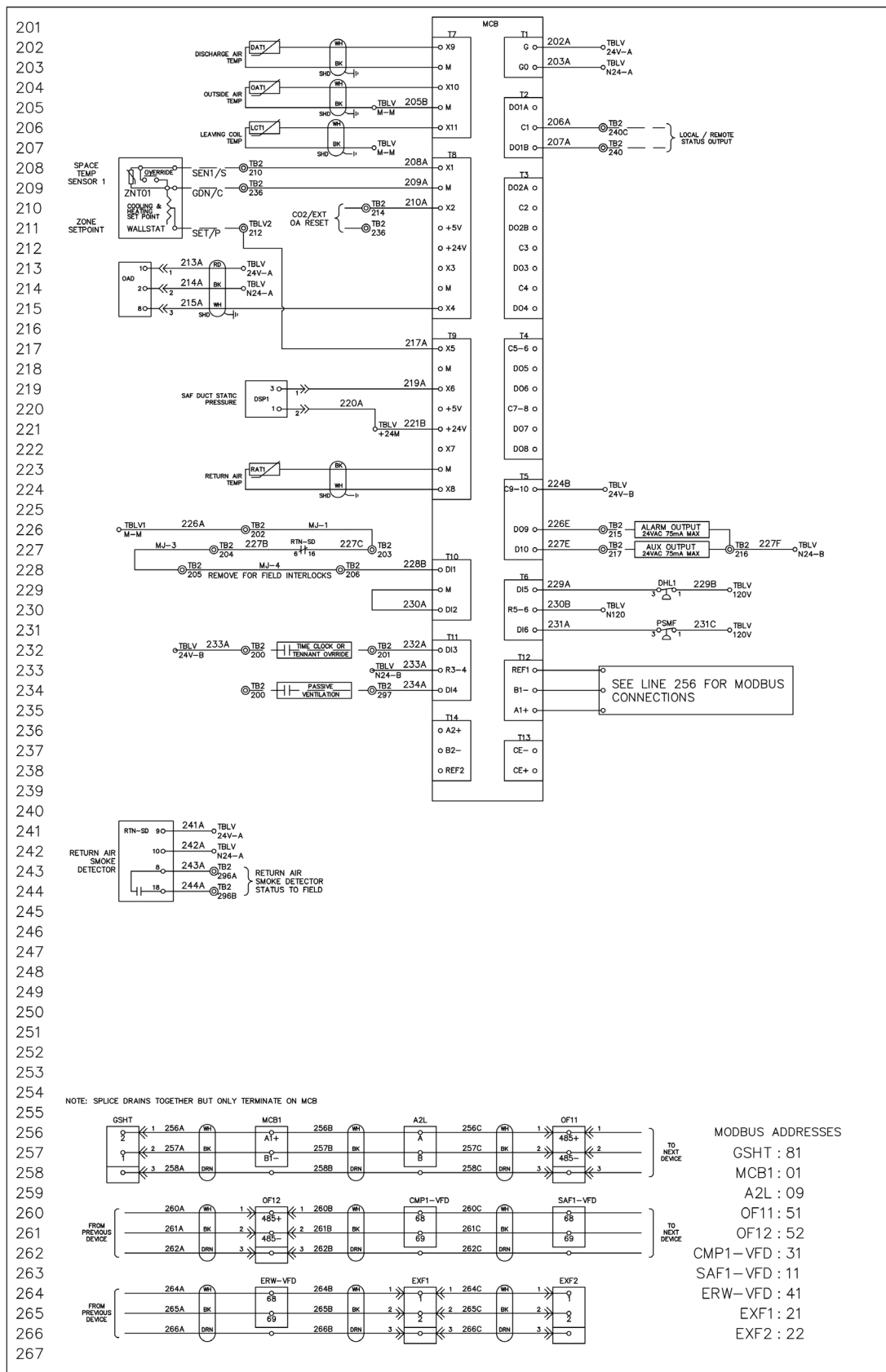

Figure 145: Typical C Cabinet, 460V, Gas Heat, Dual Disconnect Wiring Diagram (3)

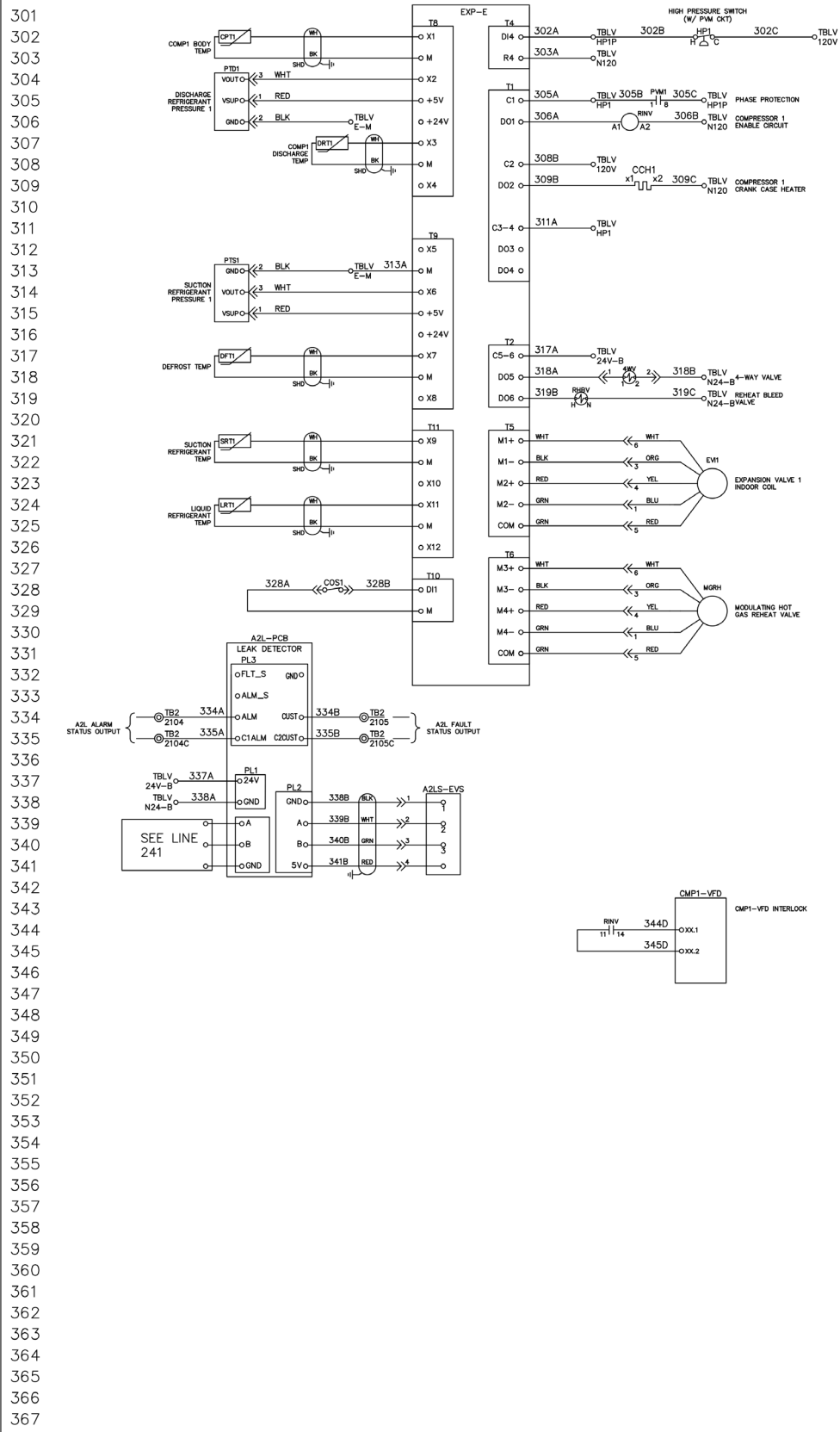
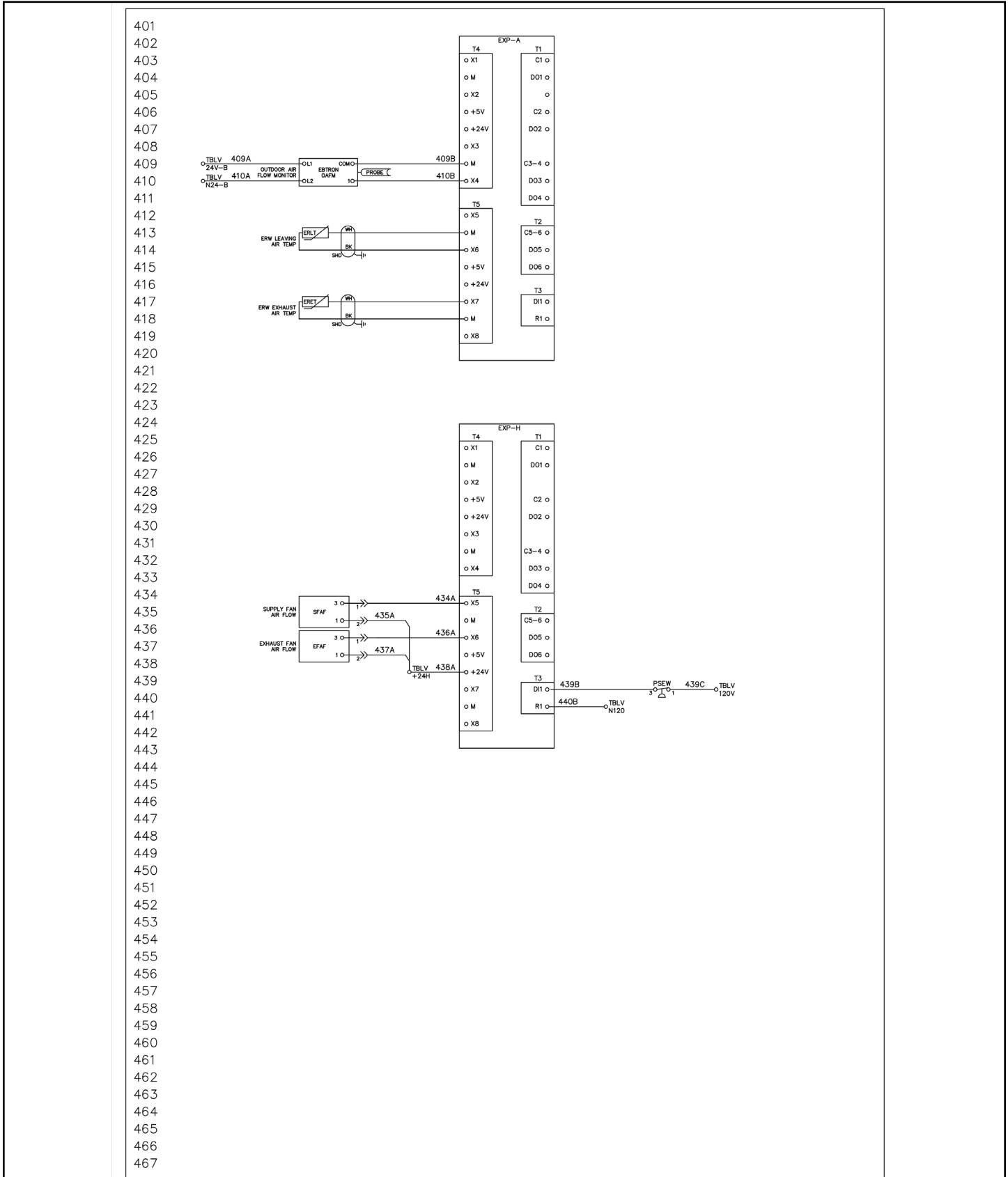



Figure 146: Typical C Cabinet, 460V, Gas Heat, Dual Disconnect Wiring Diagram (4)



Preparing for Start Up

Pre-Start of Unit

 DANGER
<p>Electric shock and moving machinery hazard. Can cause severe equipment damage, personal injury, or death.</p> <p>Disconnect and tag out all electrical power before servicing this equipment.</p> <p>All start-up and service work must be performed only by trained, experienced technicians familiar with the hazards of working on this type of equipment.</p> <p>Read and follow the unit controller operation manual before operating or servicing.</p> <p>Bond the equipment frame to the building electrical ground through grounding terminal or other approved means.</p>

All units are completely run tested at the factory to ensure proper operation prior to installation. However, to ensure proper operation once the unit is installed, the following check, test, and start procedures must be performed to properly start the unit. To obtain full warranty coverage, complete and sign the check, test, and start form supplied with the unit and return it to Daikin Applied.

A representative of the owner or the operator of the equipment should be present during start-up to receive instructions in the operation, care, and maintenance of the unit.

Spring Isolated Fans

DPS 016–31 Only

 WARNING
<p>Moving machinery hazard. Can cause severe personal injury or death. Before servicing equipment, disconnect power and lockout. More than one disconnect may be required to de-energize unit. Prior to operating the fans for the first time, refer to 7. Verify the rotation is correct. on page 135.</p>

Releasing Spring Mounts

The supply fan on DPS 16-31 units is spring isolated due to the relatively larger fan and increased applied energy.

The spring-mounted supply fan is locked down with four shipping bolts for shipment. Remove each shipping bolt before operating the fans. [Figure 147](#) shows a typical spring mount with a height adjustment nut and a shipping bolt. After removing the shipping bolts, rock the fan assembly by hand to check for freedom of movement.

Adjusting Spring Mounts

During operation all fans should ride level. Level the fan assembly by performing the following:

1. Loosen the 3/8" cap screw (do not remove).
2. Loosen the spring cap nut.
3. Rotate the 5/8" adjustment nut counter-clockwise to raise the fan assembly, or clockwise to lower the fan assembly.
4. Tighten the 3/8" cap screw.
5. Tighten the spring cap nut.

Figure 147: Spring Mounts

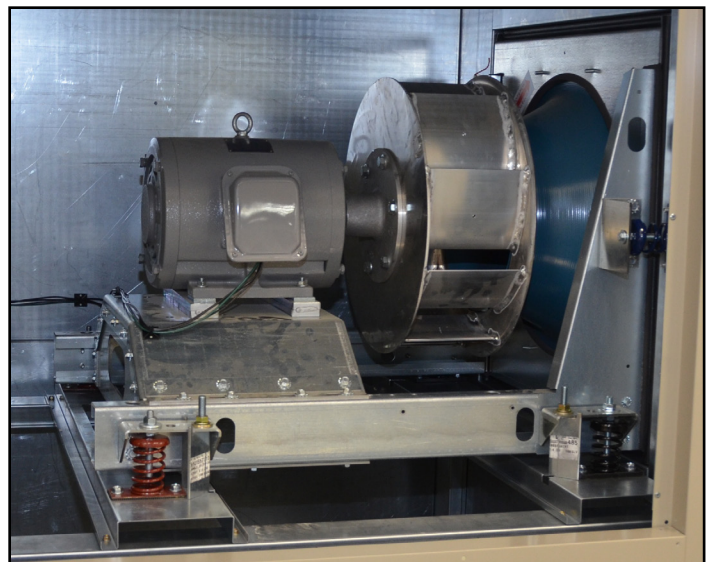

Servicing Control Panel Components



Hazardous voltage. May cause severe personal injury or death.

Disconnect electric power before servicing equipment.

Before Start-Up

1. Remove shipping bolts from compressor(s).
2. Verify that the unit is completely and properly installed with ductwork connected.
3. Verify that all construction debris is removed, and that the filters are clean.
4. Verify that all electrical work is complete and properly terminated.
5. Verify that all electrical connections in the unit control panel are tight, and that the proper voltage is connected.
6. Verify all nameplate electrical data is compatible with the power supply.
7. Verify the phase voltage imbalance is no greater than 2%.
8. Verify that gas piping is complete and leak tight.
9. Verify that the shutoff cock is installed ahead of the furnace, and that all air has been bled from the gas lines.
10. Verify installation of gas flue and outside air vents.
11. Manually rotate all fans and verify that they rotate freely.
12. Verify that the evaporator condensate drain is trapped and that the drain pan is level.
13. If unit is curb mounted, verify that the curb is properly flashed to prevent water leakage.
14. Review the equipment and service literature, the sequences of operation, and the wiring diagrams to become familiar with the functions and purposes of the controls and devices.
15. Determine which optional controls are included with the unit.
16. Inspect the outside and inside of the unit for any signs of damage or rough handling. Excessive air leakage would be one possible, unacceptable consequence. If any problems are found, contact the local Daikin Applied representative for instructions.

Power-Up

1. Close the unit disconnect switch.
2. Power should now be supplied to the control panel.

Phasing the Rebel Unit

The supply and return fans, inverter compressor, and condenser fans are all inverter driven and are DC voltage motors. Care has to be taken to ensure proper phasing.

1. With a phase rotation indicating tool ensure phase rotation per the wiring diagrams on the inside door of the control panel.

Fan Start-Up

NOTE: This section does not apply to outdoor air fans (OAFs).

1. Verify all duct isolation dampers are open.
2. Enter 6363 password on MicroTech keypad.
3. Ensure Occ Mode is set to "Occ".
4. Change Control Mode to "FanOnly".
5. Once the MicroTech unit state changes from Start to Recirc (or FanOnly if 100% OA unit without recirculation), the SAFs and RF/EFs will receive command to run.
6. If any of the fans do not run, check the manual motor protectors or that the circuit breakers have not tripped.
7. Verify the rotation is correct.

Check, Test, and Start the Unit

Economizer Start-Up

NOTE: This applies to units with modulating outdoor air dampers. 100% OA units will have OAD 100% open if the unit is not in Off or Start state.

1. Check whether the outdoor air is suitable for free cooling.
2. At the keypad, set the cooling setpoint low enough so the controller calls for cooling.
3. Place the unit into cooling mode through the keypad menu.
4. Observe the outdoor air dampers:
 - a. If the outdoor enthalpy is low, the control algorithm should start to modulate the dampers open to maintain the discharge air setpoint.
 - b. If the outdoor enthalpy is high, the dampers should maintain their minimum position.

NOTE: It may not be possible to check the economizer operation in both low and high enthalpy states on the same day. If this is the case, repeat this procedure on another day when the opposite outdoor air enthalpy conditions exist.

Compressor Start-Up

CAUTION

Low ambient temperature hazard. Can cause compressor damage. Do not attempt to start up and check out the refrigeration system when the outdoor air temperature is below 0°F.

1. Inspect all refrigerant piping and look for leaks by looking for refrigerant oil residue. If any problem is found, reclaim any remaining refrigerant, fix the problem and then add the circuit's nameplate charge by weight before proceeding.
2. With the supply fan operational, prepare for compressor operation. Verify that the crankcase heaters are operating. **These should operate for at least 24 hours before starting the compressors.**

Perform the Following Procedure:

NOTICE

Venting refrigerant to atmosphere is not allowed per most local laws and/or codes.

1. At the keypad, set unit to Occupied and set the Occupied Cooling Setpoint low enough so that the controller will call for cooling.
2. Verify that the variable compressor starts. If the compressor motor hums but does not run, verify that it is phased correctly between the inverter board and compressor.
3. Verify that the fixed compressor starts (if applicable). Use a phase rotation meter to confirm phasing is clockwise. If the compressor is rotating properly when energized, the suction pressure will decrease and the discharge pressure will increase. If the compressor is rotating in reverse, the sound level is louder and current draw is reduced substantially. After several minutes of operation rotating in the incorrect direction, the compressor's motor protector may trip. Tripping will not damage the compressor as long as it does not continue to repeat this cycle.

NOTE: Discharge air setpoint may need to be lowered to ensure fixed compressor starts up.

4. The compressor should operate continuously while there is a call for cooling. If the compressor cycles on and off on its low pressure switch, perform the following:
 - a. Verify that the circuit is not short of refrigerant.
 - b. Check for low airflow across the evaporator coil.
 - c. Check for clogged filters.
 - d. Check for restricted ductwork.
 - e. Check for very low temperature return air entering the unit.
 - f. Verify that the liquid line components, expansion valve, and distributor tubes are feeding the evaporator coil.
 - g. Verify that all air handling section panels are closed.
4. Verify that the condenser fans are cycling and rotating properly (blowing air upward). When the compressor starts, at least one condenser fan should also start.

Checking Subcooling

Following are recommendations for checking subcooling:

1. Run unit until it reaches steady state. Close the unit section doors. Running the unit with its doors open will affect system operation.
2. Subcooling can be read from the MicroTech unit controller.

Set Up for Optimum Control

The Outdoor Air Sensor Must be Calibrated.

- Compare the MicroTech OAT reading to an external temperature measuring device. Go to the Quick Menu and OA Temp.
- If there is more than 1.0°F difference between the two readings [Note the OAT reading should be taken after the outdoor fans have been running for at least 1 minute.], then correct this difference on the keypad. Go to Service Menus (see the unit controller manual for details), Sensor Offsets, and find OA temp to make the required adjustment. The adjustment has a range setting of +/- 10.0°F.

Air Balancing

⚠ WARNING

Moving machinery hazard. Can cause severe personal injury or death. Do not use a mechanically driven tachometer to measure the speed of return fans on this fan arrangement. Use a strobe tachometer.

The following should be performed by a qualified air balancing technician:

1. Check the operating balance with the economizer dampers positioned for both full outdoor air and minimum outdoor air.
2. Verify that the total airflow will never be less than that required for operation of the electric heaters or gas furnace.
3. When the final drive adjustments or changes are complete, check the current draw of the supply fan motors. The amperage must not exceed the service factor stamped on the motor nameplate

Minimum and maximum airflow/rpm settings can be adjusted using the MicroTech unit controller.

Energy Recovery Wheel

Prestartup Checks

1. By hand, turn wheel clockwise (as viewed from the pulley side) to verify wheel turns freely through 360° rotation.
2. During rotation confirm wheel segments are fully engaged in the wheel frame and segment retainers are completely fastened
3. With hands and objects away from moving parts, apply power and confirm wheel rotation. Wheel rotates clockwise as viewed from the pulley side.
4. If wheel has difficulty starting, disconnect power and inspect for excessive interference between the wheel surface and each of the four (4) diameter seals.

Diameter Seal Adjustment

⚠ WARNING

Keep hands away from rotating wheel! Contact with rotating wheel can cause personal injury.

The diameter seal is set at the factory. To check the seal, slide a ¼ inch feeler gauge between the seal and the media at multiple locations on both sides of the bearing as you rotate the wheel slowly by hand (clockwise when viewed from the pulley side). Verify that the media slightly grabs the feeler gauge during the rotation. If necessary, follow the steps below to reset the seal to a slight interference fit with the wheel media.

1. Loosen diameter seal adjusting screws. See Figure 148.
2. Move adjustable diameter seals away from wheel.
3. Using a ¼ inch feeler gauge, adjust the diameter against the wheel. See Figure 148.
4. Tighten diameter seal adjusting screws.
5. Apply power per the start up procedure.

Figure 148: Energy Recovery Wheel Adjusting

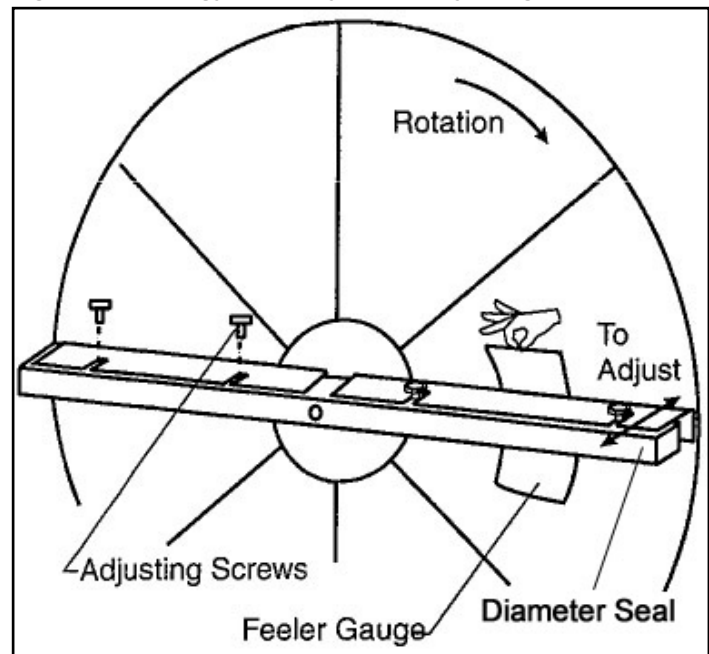

Fixed Plate Exchanger

Your Daikin Applied fixed plate exchanger is delivered completely assembled and ready to run. The core is built to provide many years of trouble-free service with minimal maintenance following proper installation and commissioning.

Figure 149: Fixed Plate Exchanger with Outdoor Air Bypass

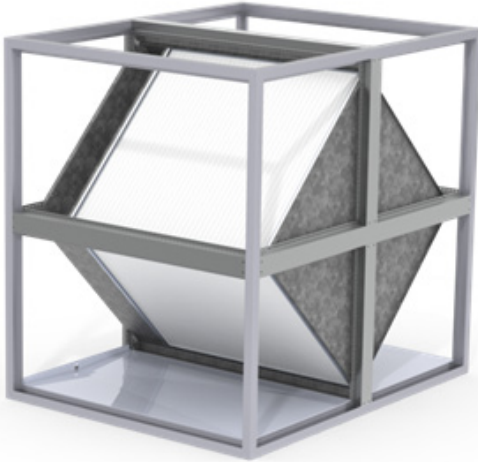

Frost Protection

During extreme cold winter conditions, the bypass is opened on the outdoor air side of the core. This minimizes the cold air across the core, allowing the exhaust air to warm the exchanger and prevent the accumulation of frost build-up on the component.

Figure 150: Frost Region

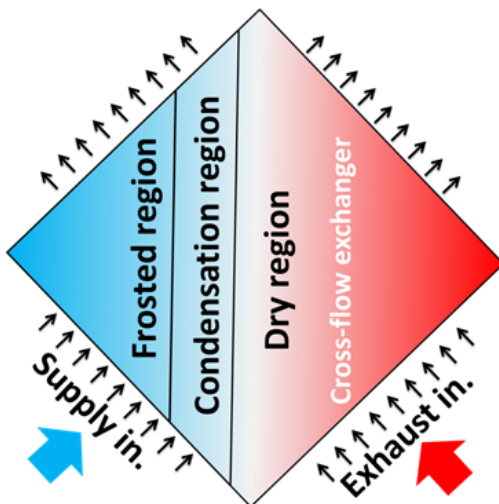

Economizer Mode

When the outside air enthalpy is less than the required supply air during cooling, outside air and/or exhaust air control dampers can be provided within the fixed plate section to reduce required mechanical cooling. This is available with the enthalpy CORE® fixed plate exchanger.

Mixed-Air System

To provide a mix of outdoor air and return air to the supply airstream, a recirculation control damper can be provided. This is available with the enthalpy CORE® fixed plate exchanger.

CORE® Enthalpy Fixed Plate Exchanger

Storage

The enthalpy core must be stored away from direct sun light and strong UV rays. If stored for an extended period of time, it is recommended to have the exchanger's faces covered to avoid dust deposition on the membrane surface or be washed with tap water.

Maintenance

The heat exchanger and damper actuators can be accessed from the four removable panels located on both sides of the heat exchanger section. Outside air, exhaust air, and bypass air damper actuators may be accessed more easily from the opposite drive side.

It is important to wash the CORE® at least once per year, using tap water and mild detergent such as Dawn®, Palmolive® or equivalent dish soap.

- Do not use a high-pressure water source
- Wash the core in place. Ensure adequate drainage via the drip pan is available for waste water
- If the CORE® is heavily soiled, prepare a solution of less than 1:100 parts water to dish soap. Otherwise, clean water will suffice
- Pour solution (or clean water) through the core, both Supply and Exhaust paths, ensuring exposure of all layers
- Rinse with clean tap water until no bubbles appear in the exiting water
- Allow the core to dry until no water is dripping out

While cleaning other adjacent components in the HVAC system, it is possible for the core to come in contact with harsher detergents. The following is a list of coil cleaners and all-purpose cleaners that have been tested with the CORE® exchanger, and what the recommendation is for exposure. Generally, contact with any coil cleaning product is not recommended, and specifically hydroxide-based cleaners should be avoided. If contact does occur, the core should be rinsed immediately as it may void the CORE® warranty.

Table 35: Cleaner Recommendations

Cleaner	Recommendation
Viper Expanding Foam	OK
CalSpray–nu-Brite	Avoid Contact
CalSpray–evap foam	OK
HD CalClean 1:40	OK
HD CalClean 1:5	Avoid Contact
Fantastik w/ Bleach	Avoid Contact
Fantastik Original	Avoid Contact

Sensible Fixed Plate Heat Exchanger

Maintenance

The sensible fixed plate heat exchangers are designed to prevent particles from coming into contact with the heat transfer surfaces. The air channels in these exchangers have been designed so that most particles contained in the air will pass straight through them. Viscous substances and those that may condense on plate surfaces present the highest risk of fouling the exchanger.

The build-up of dirt in a heat exchanger usually occurs only in the first few inches inside the upstream face of the exchanger. In this case, cleaning can be accomplished with a brush or hot water and, if needed, a mild detergent or coil cleaner approved for use on aluminum. For dirtier applications, compressed air or a water hose with spray nozzle can be used. If using a water hose, keep maximum pressure below 60 PSI (typical municipal water line pressure) and direct the water stream parallel to the plates—do not use directly against the plate surfaces.

Although the plates in the aluminum heat exchangers are made of material that is up to 0.008" thick, care must be taken when mechanical means are used to remove dirt so that the plates do not deform or tear.

Temperature Sensor Scaling

The MicroTech unit controller uses passive negative temperature coefficient (NTC) 10K ohm sensors. These sensors vary their input resistance to the MCB as the temperature changes.

Table 36: Nominal Input Resistance Versus Temperature

Temperature			R nominal (Ω)	Temperature			R nominal (Ω)	Temperature			R nominal (Ω)	Temperature			R nominal (Ω)
°F	°C			°F	°C			°F	°C			°F	°C		
-40	-40.0		336.050	-6	-21.1		103.486	28	-2.2		36.601	62	16.7		14.546
-39	-39.4		323.889	-5	-20.6		100.184	29	-1.7		35.565	63	17.2		14.179
-38	-38.9		312.212	-4	-20.0		96.999	30	-1.1		34.562	64	17.8		13.822
-37	-38.3		300.999	-3	-19.4		93.927	31	-0.6		33.591	65	18.3		13.475
-36	-37.8		290.229	-2	-18.9		90.962	32	0.0		32.650	66	18.9		13.139
-35	-37.2		279.884	-1	-18.3		88.101	33	0.6		31.739	67	19.4		12.811
-34	-36.7		269.945	0	-17.8		85.340	34	1.1		30.856	68	20.0		12.493
-33	-36.1		260.396	1	-17.2		82.676	35	1.7		30.000	69	20.6		12.184
-32	-35.6		251.218	2	-16.7		80.103	36	2.2		29.171	70	21.1		11.884
-31	-35.0		242.397	3	-16.1		77.620	37	2.8		28.368	71	21.7		11.591
-30	-34.4		233.918	4	-15.6		75.222	38	3.3		27.590	72	22.2		11.307
-29	-33.9		225.766	5	-15.0		72.906	39	3.9		26.835	73	22.8		11.031
-28	-33.3		217.928	6	-14.4		70.670	40	4.4		26.104	74	23.3		10.762
-27	-32.8		210.390	7	-13.9		68.510	41	5.0		25.394	75	23.9		10.501
-26	-32.2		203.139	8	-13.3		66.424	42	5.6		24.707	76	24.4		10.247
-25	-31.7		196.165	9	-12.8		64.408	43	6.1		24.040	77	25.0		10.000
-24	-31.1		189.455	10	-12.2		62.460	44	6.7		23.394	78	25.6		9.760
-23	-30.6		182.998	11	-11.7		60.578	45	7.2		22.767	79	26.1		9.526
-22	-30.0		176.785	12	-11.1		58.759	46	7.8		22.159	80	26.7		9.298
-21	-29.4		170.804	13	-10.6		57.001	47	8.3		21.569	81	27.2		9.077
-20	-28.9		165.048	14	-10.0		55.301	48	8.9		20.997	82	27.8		8.862
-19	-28.3		159.506	15	-9.4		53.658	49	9.4		20.442	83	28.3		8.652
-18	-27.8		154.169	16	-8.9		52.069	50	10.0		19.903	84	28.9		8.448
-17	-27.2		149.030	17	-8.3		50.533	51	10.6		19.380	85	29.4		8.249
-16	-26.7		144.081	18	-7.8		49.047	52	11.1		18.873	86	30.0		8.056
-15	-26.1		139.313	19	-7.2		47.610	53	11.7		18.380	87	30.6		7.868
-14	-25.6		134.720	20	-6.7		46.220	54	12.2		17.902	88	31.1		7.685
-13	-25.0		130.295	21	-6.1		44.875	55	12.8		17.438	89	31.7		7.506
-12	-24.4		126.031	22	-5.6		43.574	56	13.3		16.988	90	32.2		7.333
-11	-23.9		121.921	23	-5.0		42.315	57	13.9		16.551	91	32.8		7.164
-10	-23.3		117.960	24	-4.4		41.097	58	14.4		16.126	92	33.3		6.999
-9	-22.8		114.141	25	-3.9		39.917	59	15.0		15.714	93	33.9		6.839
-8	-22.2		110.460	26	-3.3		38.776	60	15.6		15.313	94	34.4		6.682
-7	-21.7		106.910	27	-2.8		37.671	61	16.1		14.924	95	35.0		6.530

Final Control Settings

Final Control Settings

Controller Settings for Normal Operation

When all start-up procedures are completed, set the controls and program the MicroTech unit controller for normal operation. Use the following list as a guide; some items may not apply to your unit.



1. Set the heating and cooling parameters as required for normal unit operation:
 - a. Commission Unit\Cooling Set-Up\
 1. Cooling Set-Point
 2. Cooling Set-Point
 3. Cooling Set-Point
 - b. Commission Unit\Heating Set-Up\
 1. Heating Set-Point
 2. Heating Set-Point
 3. Heating Set-Point
 - c. Commission Unit\HtgClg ChgOvr Set-Up\
 1. Heating Set-Point
 2. Heating Set-Point
 3. Heating Set-Point
2. Set the low ambient compressor lockout setpoint as required. Do not set it below 20°F.
3. Set the high ambient heat lockout temperature setpoint.
4. Set the alarm limits as required.
5. Set the duct static pressure control parameters as required.
6. Set the building static pressure control parameters as required.
7. Set the economizer control parameters as required.
8. Set the date and time in keypad menu.
9. Set the operating schedule as required using keypad menus.

NOTE: Unit operation may also be controlled by the building automation system.

Maintaining Control Parameter Records

Daikin Applied recommends that the MicroTech unit controller's setpoints and parameters be recorded and saved for future reference. If the microprocessor control board requires replacement, this record facilitates entering the unit's proper data.

R-32 Guidelines

 WARNING	
	<p>This unit contains R-32, a class A2L refrigerant that is flammable. This unit should only be installed, serviced, repaired, and disposed of by qualified personnel licensed or certified in their jurisdiction to work with R-32 refrigerant. Installation and maintenance must be done in accordance with this manual. Improper handling of this equipment can cause equipment damage, personal injury, or equipment damage.</p>
<p>Be aware that R-32 refrigerant may not contain an odor. Place in a well ventilated area to prevent accumulation of refrigerant. When installing the unit in a small room, take measures to keep the refrigerant concentration from exceeding allowable safety limits. Excessive refrigerant leaks, in the event of an accident in a closed ambient space, can lead to oxygen deficiency.</p> <p>Do not pierce or burn this unit.</p> <p>Never use an open flame during service or repair. Never store in a room with continuously operating ignition sources (for example: open flames, an operating gas appliance, or an operating electric heater.), where there is ignitable dust suspension in the air, or where volatile flammables such as thinner or gasoline are handled.</p> <p>Only use pipes, nuts, and tools intended for exclusive use with R-32 refrigerant in compliance with national codes (ASHRAE15 or IRC).</p> <p>Do not mix air or gas other than R-32 in the refrigerant system. If air enters the refrigerant system, an excessively high pressure results, which may cause equipment damage or personal injury.</p> <p>Do not use means to accelerate the defrosting process or to clean, other than those recommended by the manufacturer.</p> <p>The unit shall be stored in a room without continuously operating ignition sources (for example: open flames, an operating gas appliance, or an operating electric heater).</p>	

Maintaining and servicing R-32 refrigerant should only be performed as recommended by this manual and by personnel licensed or certified in their jurisdiction to handle A2L refrigerants. Dismantling the unit and treatment of the refrigerant, oil, and additional parts must be done in accordance with the relevant local, state, and national regulations. Refrigerant sensors for refrigerant detection shall only be replaced with sensors specified by the appliance manufacturer.

Only use tools meant for use on R-32 refrigerant, such as a gauge manifold, charge hose, gas leak detector, reverse flow check valve, refrigerant charge base, vacuum gauge, or refrigerant recovery equipment.

 WARNING
<p>The unit must be stored and/or located to prevent mechanical damage of the refrigeration system. Do not store the unit near sources of open flame, electrical switching devices, or hot surfaces above 1292°F (700°C). If the unit is stored indoors, the storage area should be larger than the Minimum Room Area specified in this document. The storage space should be well ventilated and not allow for the stagnation of leaked refrigerant. Failure to do so may result in a fire or explosion hazard.</p>

 WARNING
<p>Auxiliary devices which may be a POTENTIAL IGNITION SOURCE shall not be installed in the duct work. Examples of POTENTIAL IGNITION SOURCES are hot surfaces with temperatures exceeding 1292°F (700°C) and electric switching devices.</p>

 WARNING
<p>Only auxiliary devices approved by Daikin Applied or declared suitable for installation with R-32 shall be installed in the connecting ductwork.</p>

Maintenance

- Portable equipment shall be repaired outside or in a workshop specially equipped for servicing units with **FLAMMABLE REFRIGERANTS**.
- Ensure sufficient ventilation at the repair place.
- Be aware that malfunction of the equipment may be caused by refrigerant loss and a refrigerant leak is possible.
- Discharge capacitors in a way that won't cause any spark. The standard procedure to short circuit the capacitor terminals usually creates sparks.
- Reassemble sealed enclosures accurately. If seals are worn, replace them.
- Check safety equipment before putting into service.

Repair

- Portable equipment shall be repaired outside or in a workshop specially equipped for servicing units with **FLAMMABLE REFRIGERANTS**.
- Ensure sufficient ventilation at the repair place.
- Be aware that malfunction of the equipment may be caused by refrigerant loss and a refrigerant leak is possible.
- Discharge capacitors in a way that won't cause any spark.
- When brazing is required, the following procedures shall be carried out in the right order:
 - Remove the refrigerant. If the recovery is not required by national regulations, drain the refrigerant to the outside. Take care that the drained refrigerant will not cause any danger. In doubt, one person should guard the outlet. Take special care that drained refrigerant will not float back into the building.
 - Evacuate the refrigerant circuit.
 - Remove parts to be replaced by cutting, not by flame.
 - Purge the braze point with nitrogen during the brazing procedure.
 - Carry out a leak test before charging with refrigerant.
- Reassemble sealed enclosures accurately. If seals are worn, replace them.
- Check safety equipment before putting into service.

Lubrication

R-32 should only be used with manufacturer-approved oil, such as DAPHNE FW68DE. The HFC refrigerant components in R-32 will not be compatible with mineral oil or alkylbenzene lubricants. R-32 systems will be charged with the OEM recommended lubricant, ready for use with R-32.

Leak Detection

NEVER use the following when attempting to detect R-32 refrigerant leaks:

- A halide torch (or any other detector using a naked flame)
- Substances containing chlorine
- Electronic leak detection

Table 37: Minimum Room Area Multipliers by Altitude

Altitude (Meters)	Minimum Room Area Multiplier
0	1
305	1.047
500	1.078
750	1.117
1000	1.156
1250	1.195
1500	1.234
1750	1.273
2000	1.312
2250	1.351
2500	1.39
2750	1.429
3000	1.468
3250	1.507
3500	1.546

Table 38: Minimum Room Area and Airflow

Cabinet	Unit Size (Tons)	Configuration	Reheat	Refrigerant Charge (lbs)	Minimum Room Area Amin (ft ²)	Minimum Airflow Qmin (ft ³ /min)
A	3	COOL	NONE	5.8	94	169
A	3	ASHP	NONE	10	108	195
A	3	COOL	MICRO	6.8	95	172
A	3	ASHP	MICRO	10.5	110	198
A	4	COOL	NONE	6.3	95	171
A	4	ASHP	NONE	10.5	113	203
A	4	COOL	MICRO	7	96	173
A	4	ASHP	MICRO	11	114	206
A	5	COOL	NONE	7.3	104	187
A	5	ASHP	NONE	12	176	317
A	5	COOL	MICRO	7.8	105	189
A	5	ASHP	MICRO	13	177	320
A	6	COOL	NONE	7.3	104	188
A	6	ASHP	NONE	12	176	318
A	6	COOL	MICRO	7.8	106	191
A	6	ASHP	MICRO	13	178	321
B	7	COOL	NONE	13.3	224	404
B	7	ASHP	NONE	18	215	388
B	7	COOL	MICRO	14	226	408
B	7	ASHP	MICRO	18.8	217	392
B	10	COOL	NONE	13.3	250	451
B	10	ASHP	NONE	18	242	437
B	10	COOL	MICRO	14	252	454
B	10	ASHP	MICRO	18.8	244	440
B	12	COOL	NONE	15.5	320	577
B	12	ASHP	NONE	30.9	446	805
B	12	COOL	MICRO	16.3	322	581
B	12	ASHP	MICRO	31.7	448	809
B	15	COOL	NONE	18.8	358	645
B	15	ASHP	NONE	32.3	485	876
B	15	COOL	MICRO	19.5	360	649
B	15	ASHP	MICRO	35	487	879
B	17	COOL	NONE	18.8	358	645
B	17	ASHP	NONE	32.3	485	876
B	17	COOL	MICRO	19.5	360	649
B	17	ASHP	MICRO	35	487	879
C	16	COOL	NONE	27	390	704
C	16	ASHP	NONE	34.3	496	895
C	16	COOL	MICRO	27.5	398	717
C	16	ASHP	MICRO	34.9	505	910
C	18	COOL	NONE	27	390	704
C	18	ASHP	NONE	34.3	496	895
C	18	COOL	MICRO	27.5	398	717
C	18	ASHP	MICRO	34.9	505	910
C	20	COOL	NONE	31.2	451	814

(continued)						
Cabinet	Unit Size (Tons)	Configuration	Reheat	Refrigerant Charge (lbs)	Minimum Room Area Amin (ft ²)	Minimum Airflow Qmin (ft ³ /min)
C	20	ASHP	NONE	45.1	652	1,177
C	20	COOL	MICRO	31.7	458	827
C	20	ASHP	MICRO	45.7	661	1,192
C	25	COOL	NONE	31	448	809
C	25	ASHP	NONE	45.4	656	1,184
C	25	COOL	MICRO	31.63	457	825
C	25	ASHP	MICRO	46	665	1,200
C	30	COOL	NONE	34.9	505	910
C	30	ASHP	NONE	48	694	1,252
C	30	COOL	MICRO	35.5	513	926
C	30	ASHP	MICRO	48.6	703	1,268
C	31	COOL	NONE	34.9	505	910
C	31	ASHP	NONE	48	694	1,252
C	31	COOL	MICRO	35.5	513	926
C	31	ASHP	MICRO	48.6	703	1,268

Pressure Testing and Refrigerant Evacuation

- Make sure that air or any matter other than R-32 refrigerant does not get into the refrigeration cycle.
- If refrigerant gas leaks occur, ventilate the room as soon as possible.
- R-32 should always be recovered and never released directly into the environment.
- Only use tools meant for use on R-32 refrigerant (such as a gauge manifold, charging hose, or vacuum pump adapter).

— Protect from heat and direct sunlight

- Maximum storage temperature:

— 104°F (40°C)

Commissioning

- Ensure that the floor area is sufficient for the REFRIGERANT CHARGE or that the ventilation duct is assembled in a correct manner.
- Connect the pipes and carry out a leak test before charging with refrigerant.
- Check safety equipment before putting into service.

Handling and Storage

Precautions for safe handling

Waste air is to be released into the atmosphere only via suitable separators. Open and handle receptacle with care.

Information about fire and explosion protections

Keep ignition sources away. Do not smoke. Protect against electrostatic charges.

Conditions for safe storage

- Requirements to be met by storerooms and receptacles:
 - Store only in unopened original receptacles
 - Store in a cool and dry location
- Information about Storage in one common storage facility:
 - Not required
- Further information about storage conditions:
 - Keep container tightly sealed
 - Store in cool, dry conditions in well sealed receptacle

Decommissioning

- If the safety is affected when the equipment is put out of service, the REFRIGERANT CHARGE shall be removed before decommissioning.
- Ensure sufficient ventilation at the equipment location.
- Be aware that malfunction of the equipment may be caused by refrigerant loss and a refrigerant leak is possible.
- Discharge capacitors in a way that won't cause any spark.
- Remove the refrigerant. If the recovery is not required by national regulations, drain the refrigerant to the outside. Take care that the drained refrigerant will not cause any danger. In doubt, one person should guard the outlet. Take special care that drained refrigerant will not float back into the building.

Recovery

NOTE: Refer to "Refrigerant Charging and/or Evacuation" on page 154 for details.

When removing refrigerant from a system, either for servicing or decommissioning, it is recommended good practice that all

refrigerants are removed safely. When transferring refrigerant into cylinders, ensure that only appropriate refrigerant recovery cylinders are employed. Ensure that the correct number of cylinders for holding the total system charge is available. All cylinders to be used are designated for the recovered refrigerant and labeled for that refrigerant (i. e. special cylinders for the recovery of refrigerant). Cylinders shall be complete with pressure-relief valve and associated shut-off valves in good working order. Empty recovery cylinders are evacuated and, if possible, cooled before recovery occurs.

The recovery equipment shall be in good working order with a set of instructions concerning the equipment that is at hand and shall be suitable for the recovery of all appropriate refrigerants including, when applicable, FLAMMABLE REFRIGERANTS. In addition, a set of calibrated weighing scales shall be available and in good working order. Hoses shall be complete with leak-free disconnect couplings and in good condition. Before using the recovery machine, check that it is in satisfactory working order, has been properly maintained and that any associated electrical components are sealed to prevent ignition in the event of a refrigerant release. Consult manufacturer if in doubt.

The recovered refrigerant shall be returned to the refrigerant supplier in the correct recovery cylinder, and the relevant waste transfer note arranged. Do not mix refrigerants in recovery units and especially not in cylinders.

If compressors or compressor oils are to be removed, ensure that they have been evacuated to an acceptable level to make certain that FLAMMABLE REFRIGERANT does not remain within the lubricant. The evacuation process shall be carried out prior to returning the compressor to the suppliers. Only electric heating to the compressor body shall be employed to accelerate this process. When oil is drained from a system, it shall be carried out safely.

Disposal

- Waste treatment method recommendation:
 - Must be specially treated adhering to official regulations.
 - Incineration in an adequate incinerator is recommended.
 - Uncleaned packaging disposal must be made according to official regulations.
- Ensure sufficient ventilation at the working place.
- Remove the refrigerant. If the recovery is not required by national regulations, drain the refrigerant to the outside. Take care that the drained refrigerant will not cause any danger. In doubt, one person should guard the outlet. Take special care that drained refrigerant will not float back into the building.
- Evacuate the refrigerant circuit.
- Purge the refrigerant circuit with nitrogen for 5 min.
- Evacuate again.
- Cut out the compressor and drain the oil.

Competence of Personnel

Information of procedures additional to usual information for refrigerating appliance installation, repair, maintenance and

decommission procedures is required when an appliance with flammable refrigerants is affected.

The training of these procedures is carried out by national training organizations or manufacturers that are accredited to teach the relevant national competency standards that may be set in legislation. The achieved competence should be documented by a certificate.

Information and Training

The training should include the substance of the following

- Information about the explosion potential of flammable refrigerants to show that flammables may be dangerous when handled without care.
- Information about potential ignition sources, especially those that are not obvious, such as lighters, light switches, vacuum cleaners, electric heaters.
- Information about the different safety concepts:
 - Unventilated: Safety of the appliance does not depend on ventilation of the housing. Switching off the appliance or opening of the housing has no significant effect on the safety. Nevertheless, it is possible that leaking refrigerant may accumulate inside the enclosure and flammable atmosphere will be released when the enclosure is opened.
 - Ventilated enclosure : Safety of the appliance depends on ventilation of the housing. Switching off the appliance or opening of the enclosure has a significant effect on the safety. Care should be taken to ensure sufficient ventilation before.
 - Ventilated room: Safety of the appliance depends on the ventilation of the room. Switching off the appliance or opening of the housing has no significant effect on the safety. The ventilation of the room shall not be switched off during repair procedures.
- Information about refrigerant detectors:
 - Principle of function, including influences on the operation.
 - Procedures, how to repair, check or replace a refrigerant detector or parts of it in a safe way.
 - Procedures, how to disable a refrigerant detector in case of repair work on the refrigerant carrying parts.
- Information about the concept of sealed components and sealed enclosures according to IEC 60079-15:2010.
- Information about the correct working procedures:
 - Commissioning
 - a. Ensure that the floor area is sufficient for the refrigerant charge or that the ventilation duct is assembled in a correct manner.
 - b. Connect the pipes and carry out a leak test before charging with refrigerant.
 - c. Check safety equipment before putting into service.

— Maintenance

- a. Portable equipment shall be repaired outside or in a workshop specially equipped for servicing units with flammable refrigerants.
- b. Ensure sufficient ventilation at the repair place.
- c. Be aware that malfunction of the equipment may be caused by refrigerant loss and a refrigerant leak is possible.
- d. Discharge capacitors in a way that won't cause any spark. The standard procedure to short circuit the capacitor terminals usually creates sparks.
- e. Reassemble sealed enclosures accurately. If seals are worn, replace them.
- f. Check safety equipment before putting into service.

— Repair

- a. Portable equipment shall be repaired outside or in a workshop specially equipped for servicing units with flammable refrigerants.
- b. Ensure sufficient ventilation at the repair place.
- c. Be aware that malfunction of the equipment may be caused by refrigerant loss and a refrigerant leak is possible.
- d. Discharge capacitors in a way that won't cause any spark.
- e. When brazing is required, the following procedures shall be carried out in the right order:
 - Remove the refrigerant. If the recovery is not required by national regulations, drain the refrigerant to the outside. Take care that the drained refrigerant will not cause any danger. In doubt, one person should guard the outlet. Take special care that drained refrigerant will not float back into the building.
 - Evacuate the refrigerant circuit.
 - Remove parts to be replaced by cutting, not by flame.
 - Purge the braze point with nitrogen during the brazing procedure.
 - Carry out a leak test before charging with refrigerant.
 - a. Reassemble sealed enclosures accurately. If seals are worn, replace them.
 - b. Check safety equipment before putting into service.

— Decommissioning

- a. If the safety is affected when the equipment is putted out of service, the refrigerant charge shall be removed before decommissioning.
- b. Ensure sufficient ventilation at the equipment location.
- c. Be aware that malfunction of the equipment may be caused by refrigerant loss and a refrigerant leak is possible.
- d. Discharge capacitors in a way that won't cause any spark.
- e. Remove the refrigerant. If the recovery is not

required by national regulations, drain the refrigerant to the outside. Take care that the drained refrigerant will not cause any danger. In doubt, one person should guard the outlet. Take special care that drained refrigerant will not float back into the building.

— Disposal

- a. Ensure sufficient ventilation at the working place.
- b. Remove the refrigerant. If the recovery is not required by national regulations, drain the refrigerant to the outside. Take care that the drained refrigerant will not cause any danger. In doubt, one person should guard the outlet. Take special care that drained refrigerant will not float back into the building.

Information on Servicing

Checks to the area

Prior to beginning work on systems containing FLAMMABLE REFRIGERANTS, safety checks are necessary to ensure that the risk of ignition is minimized

Work procedure

Work shall be undertaken under a controlled procedure so as to minimize the risk of a flammable gas or vapor being present while the work is being performed.

General work area

All maintenance staff and others working in the local area shall be instructed on the nature of work being carried out. Work in confined spaces shall be avoided.

Checking for presence of refrigerant

The area shall be checked with an appropriate refrigerant detector prior to and during work, to ensure the technician is aware of potentially toxic or flammable atmospheres. Ensure that the leak detection equipment being used is suitable for use with all applicable refrigerants; i.e., non-sparking, adequately sealed or intrinsically safe.

Presence of fire extinguisher

If any hot work is to be conducted on the refrigerating equipment or any associated parts, appropriate fire extinguishing equipment shall be available to hand. Have a dry powder or CO₂ fire extinguisher adjacent to the charging area.

No ignition sources

No person carrying out work in relation to a REFRIGERATING SYSTEM which involves exposing any pipe work shall use any sources of ignition in such a manner that it may lead to the risk of fire or explosion. All possible ignition sources, including cigarette smoking, should be kept sufficiently far away from the site of installation, repairing, removing and disposal, during which refrigerant can possibly be released to the surrounding space. Prior to work taking place, the area around the equipment is to be surveyed to make sure that there are no flammable hazards or ignition risks. "No Smoking" signs shall be displayed.

Ventilated area

Ensure that the area is in the open or that it is adequately ventilated before breaking into the system or conducting any hot work. A degree of ventilation shall continue during the period that the work is carried out. The ventilation should safely disperse any released refrigerant and preferably expel it externally into the atmosphere.

Checks to the refrigerating equipment

Where electrical components are being changed, they shall be fit for the purpose and to the correct specification. At all times the manufacturer's maintenance and service guidelines shall be followed. If in doubt, consult the manufacturer's technical department for assistance.

The following checks shall be applied to installations using FLAMMABLE REFRIGERANTS:

- the actual REFRIGERANT CHARGE is in accordance with the room size within which the refrigerant containing parts are installed;
- the ventilation machinery and outlets are operating adequately and are not obstructed;
- if an indirect refrigerating circuit is being used, the secondary circuit shall be checked for the presence of refrigerant;
- marking to the equipment continues to be visible and legible. Markings that are illegible shall be corrected;
- refrigerating pipe or components are installed in a position where they are unlikely to be exposed to any substance which may corrode refrigerant containing components, unless the components are constructed of materials which are inherently resistant to being corroded or are suitably protected against being so corroded.

Checks to electrical devices

Repair and maintenance to electrical components shall include initial safety checks and component inspection procedures. If a fault exists that could compromise safety, then no electrical supply shall be connected to the circuit until it is satisfactorily dealt with. If the fault cannot be corrected immediately but it is necessary to continue operation, an adequate temporary solution shall be used. This shall be reported to the owner of the equipment so all parties are advised.

Initial safety checks shall include:

- that capacitors are discharged: this shall be done in a safe manner to avoid possibility of sparking;
- that no live electrical components and wiring are exposed while charging, recovering or purging the system;
- that there is continuity of earth bonding.

Repairs to sealed components

- During repairs to sealed components, all electrical supplies shall be disconnected from the equipment being worked upon prior to any removal of sealed covers, etc. If it is absolutely necessary to have an electrical supply to equipment during servicing, then a permanently operating

form of leak detection shall be located at the most critical point to warn of a potentially hazardous situation.

- Particular attention shall be paid to the following to ensure that by working on electrical components, the casing is not altered in such a way that the level of protection is affected. This shall include damage to cables, excessive number of connections, terminals not made to original specification, damage to seals, incorrect fitting of glands, etc.
- Ensure that the apparatus is mounted securely.
- Ensure that seals or sealing materials have not degraded to the point that they no longer serve the purpose of preventing the ingress of flammable atmospheres. Replacement parts shall be in accordance with the manufacturer's specifications.

Repair to intrinsically safe components

- Do not apply any permanent inductive or capacitance loads to the circuit without ensuring that this will not exceed the permissible voltage and current permitted for the equipment in use.
- Intrinsically safe components are the only types that can be worked on while live in the presence of a flammable atmosphere. The test apparatus shall be at the correct rating.
- Replace components only with parts specified by the manufacturer. Other parts may result in the ignition of refrigerant in the atmosphere from a leak.

NOTE: The use of silicon sealant can inhibit the effectiveness of some types of leak detection equipment. Intrinsically safe components do not have to be isolated prior to working on them.

Cabling

- Check that cabling will not be subject to wear, corrosion, excessive pressure, vibration, sharp edges or any other adverse environmental effects. The check shall also take into account the effects of aging or continual vibration from sources such as compressors or fans.

Detection of flammable refrigerants

- Under no circumstances shall potential sources of ignition be used in the searching for or detection of refrigerant leaks. A halide torch (or any other detector using a naked flame) shall not be used.
- The following leak detection methods are deemed acceptable for all refrigerant systems.
- Electronic leak detectors may be used to detect refrigerant leaks but, in the case of FLAMMABLE REFRIGERANTS, the sensitivity may not be adequate, or may need re-calibration. (Detection equipment shall be calibrated in a refrigerant-free area.) Ensure that the detector is not a potential source of ignition and is suitable for the refrigerant used. Leak detection equipment shall be set at a percentage of the LFL of the refrigerant and shall be calibrated to the refrigerant employed, and the appropriate percentage of gas (25 % maximum) is confirmed.
- Leak detection fluids are also suitable for use with most

refrigerants but the use of detergents containing chlorine shall be avoided as the chlorine may react with the refrigerant and corrode the copper pipe-work.

NOTE: Examples of leak detection fluids are:

- bubble method.
- fluorescent method agents.
- If a leak is suspected, all naked flames shall be removed/ extinguished.
- If a leakage of refrigerant is found which requires brazing, all of the refrigerant shall be recovered from the system, or isolated (by means of shut off valves) in a part of the system remote from the leak. Removal of refrigerant shall be according to instructions above.

Removal and evacuation

- When breaking into the refrigerant circuit to make repairs, or for any other purpose, conventional procedures shall be used. However, for flammable refrigerants it is important that best practice be followed, since flammability is a consideration.
- The following procedure shall be adhered to:
 - a. Safely remove refrigerant following local and national regulations.
 - b. Evacuate refrigerant from circuit.
 - c. Purge the circuit with inert gas.
 - d. Evacuate (optional for A2L).
 - e. Purge the inert gas (optional for A2L)
 - f. Continuously flush or purge with inert gas when using flame to open circuit.
 - g. Open the circuit by cutting or brazing.
- The refrigerant charge shall be recovered into the correct recovery cylinders if venting is not allowed by local and national codes. For appliances containing flammable refrigerants, the system shall be purged with oxygen-free nitrogen to render the appliance safe for flammable refrigerants. This process might need to be repeated several times.
- Compressed air or oxygen shall not be used for purging refrigerant systems.
- For appliances containing flammable refrigerants, refrigerants purging shall be achieved by breaking the vacuum in the system with oxygen-free nitrogen and continuing to fill until the working pressure is achieved, then venting to atmosphere, and finally pulling down to a vacuum (optional for A2L).
- When the final oxygen-free nitrogen charge is used, the system shall be vented down to atmospheric pressure to enable work to take place.
- Ensure that the outlet for the vacuum pump is not close to any potential ignition sources and that ventilation is available.

Charging procedures

In addition to conventional charging procedures, the following requirements shall be followed.

- Ensure that contamination of different refrigerants does not occur when using charging equipment.
- Hoses or lines shall be as short as possible to minimize the amount of refrigerant contained in them.
- Cylinders shall be kept in an appropriate position according to the instructions.
- Ensure that the REFRIGERATING SYSTEM is earthed prior to charging the system with refrigerant.
- Label the system when charging is complete (if not already).
- Extreme care shall be taken not to overfill the REFRIGERATING SYSTEM.
- Prior to recharging the system, it shall be pressure-tested with the appropriate purging gas. The system shall be leak-tested on completion of charging but prior to commissioning. A follow up leak test shall be carried out prior to leaving the site.

Decommissioning

Before carrying out this procedure, it is essential that the technician is completely familiar with the equipment and all its detail. It is recommended good practice that all refrigerants are recovered safely.

Prior to the task being carried out, an oil and refrigerant sample shall be taken in case analysis is required prior to re-use of recovered refrigerant.

It is essential that electrical power is available before the task is commenced.

- Become familiar with the equipment and its operation.
- Isolate system electrically.
- Before attempting the procedure, ensure that mechanical handling equipment is available, if required, for handling refrigerant cylinders; all personal protective equipment is available and being used correctly; the recovery process is supervised at all times by a competent person; recovery equipment and cylinders conform to the appropriate standards.
- Pump down refrigerant system, if possible.
- If a vacuum is not possible, make a manifold so that refrigerant can be removed from various parts of the system.
- Make sure that cylinder is situated on the scales before recovery takes place.
- Start the recovery machine and operate in accordance with instructions.

- Do not overfill cylinders (no more than 80 % volume liquid charge).
- Do not exceed the maximum working pressure of the cylinder, even temporarily.
- When the cylinders have been filled correctly and the process completed, make sure that the cylinders and the equipment are removed from site promptly and all isolation valves on the equipment are closed off.
- Recovered refrigerant shall not be charged into another REFRIGERATING SYSTEM unless it has been cleaned and checked.
- If compressors or compressor oils are to be removed, ensure that they have been evacuated to an acceptable level to make certain that FLAMMABLE REFRIGERANT does not remain within the lubricant. The evacuation process shall be carried out prior to returning the compressor to the suppliers. Only electric heating to the compressor body shall be employed to accelerate this process. When oil is drained from a system, it shall be carried out safely.

Labeling

Equipment shall be labeled stating that it has been de-commissioned and emptied of refrigerant. The label shall be dated and signed. For appliances containing FLAMMABLE REFRIGERANTS, ensure that there are labels on the equipment stating the equipment contains FLAMMABLE REFRIGERANT.

Recovery

NOTE: Refer to "Refrigerant Charging and/or Evacuation" on [page 154](#) for details.

- When removing refrigerant from a system, either for servicing or decommissioning, it is recommended good practice that all refrigerants are removed safely.
- When transferring refrigerant into cylinders, ensure that only appropriate refrigerant recovery cylinders are employed. Ensure that the correct number of cylinders for holding the total system charge is available. All cylinders to be used are designated for the recovered refrigerant and labeled for that refrigerant (i. e. special cylinders for the recovery of refrigerant). Cylinders shall be complete with pressure-relief valve and associated shut-off valves in good working order. Empty recovery cylinders are evacuated and, if possible, cooled before recovery occurs.
- The recovery equipment shall be in good working order with a set of instructions concerning the equipment that is at hand and shall be suitable for the recovery of all appropriate refrigerants including, when applicable, FLAMMABLE REFRIGERANTS. In addition, a set of calibrated weighing scales shall be available and in good working order. Hoses shall be complete with leak-free disconnect couplings and in good condition. Before using the recovery machine, check that it is in satisfactory working order, has been properly maintained and that any associated electrical components are sealed to prevent ignition in the event of a refrigerant release. Consult manufacturer if in doubt.
- The recovered refrigerant shall be returned to the refrigerant supplier in the correct recovery cylinder, and the relevant waste transfer note arranged. Do not mix refrigerants in recovery units and especially not in cylinders.

Maintenance

Performing Service Maintenance

Installation and maintenance must be performed only by qualified personnel who are experienced with this type of equipment and familiar with local codes and regulations.

NOTICE

Gas or Hot Water Piping: A qualified Architect or Systems HVAC Design Engineer familiar with piping design, local codes and regulations, must provide piping design. The following manufacturer recommendations serve as a general guide and should not replace a qualified professional's piping system design.



DANGER

Moving machinery and electrical power hazards. May cause severe personal injury or death. Disconnect and lock off all power before servicing equipment.



WARNING

Sharp edges are inherent to sheet metal parts, screws, clips, and similar items. May cause personal injury.

Exercise caution when servicing equipment.

Servicing Control Panel Components

Disconnect all electric power to the unit when servicing control panel components. Before servicing, always inspect units for multiple disconnects to ensure all power is removed from the control panel and its components.



DANGER

Hazardous voltage. May cause severe personal injury or death.

Disconnect electric power before servicing equipment. More than one disconnect may be required to de-energize the unit.

NOTICE

Electrical Device Checks: Prior to any electrical component repairs and maintenance ensure that a safety check is conducted. Follow proper inspection procedures.

Servicing the A2L Refrigeration System

Service and Maintenance Professional Qualifications

All repairs and maintenance work performed on the refrigeration system must be completed by a trained professional familiar with A2L refrigerants. All qualified technicians should have verifiable credentials for competence in following areas:

- Explosion potential of flammable refrigerants
- Identifying potential ignition sources
- Ventilation safety concepts:
 - Enclosure ventilation
 - Room ventilation
- Refrigerant detectors
- Sealed components and sealed enclosures
- Proper working procedures for:
 - Commissioning
 - Maintenance
 - Repair
 - Decommissioning
 - Disposal

A2L Refrigerant System Repairs

Prior to the start of any work on refrigeration components, a safety check must be conducted to minimize the risk of ignition. The safety check must consist of following:

- Ensure all work will be conducted as part of a controlled procedure.
- Inform everyone in the immediate area of active work about the nature of the work being conducted. Where possible, avoid performing work in confined spaces.
- Check the area for the presence of refrigerant using proper leak detection equipment to prevent the potential of ignition. Refer to [A2L Refrigerant Leak Detection on page 152](#) for more details.
- Confirm proper safety equipment is available, such as:
 - Fire extinguishers.
 - Dry powder or CO2 fire extinguishers.
- Confirm work area is free from ignition sources.
- Ensure adequate ventilation is available.

A2L Refrigerant Leak Detection

When tracing a potential refrigerant leak, use proper leak detection methods to avoid ignition risks. If a leak is detected where brazing is required, isolate the refrigerant in an area away from the leak or recover the refrigerant per the recovery steps shown in [Refrigerant Recovery on page 154](#).

Acceptable methods for tracing refrigerant leaks include:

- Electronic leak detectors

NOTE: Electronic detector sensitivity settings for certain refrigerants may not be adequate or may need re-calibration. Confirm these settings for A2L refrigerants with the device manufacturer before performing a detection test.

- Non-chlorinated leak detection fluids are acceptable. Never perform leak detection tests on A2L refrigerants using fluids containing chlorine.



WARNING

Ignition sources near a potential refrigerant leak create a fire risk and may cause serious personal injury or death. If a leak is suspected during work, remove or extinguish all ignition sources around the unit.

Planned Maintenance

Preventive maintenance is the best way to avoid unnecessary expense and inconvenience. Have this system inspected at regular intervals by a qualified service technician. The required frequency of inspections depends upon the total operating time and the indoor and outdoor environmental conditions. Routine maintenance should cover the following items:

- All blowers, including furnace inducer, have sealed bearings. No lubrication is necessary.
- Tighten all wire connections.
- Clean the outside and inside coils mechanically or with cold water, if necessary. Usually any fouling is only matted on the entering air face of the coil and can be removed by brushing or vacuuming.
- Clean or replace the filters as required.
- Check for blockage of the condensate drain. Clean the condensate pan as needed.
- Check the power and control voltages.
- Check the running amperage of all motors.
- Check all operating temperatures and pressures.
- Check and adjust all temperature and pressure controls as needed.
- Check and adjust all damper linkages as needed.
- Check the operation of all safety controls.
- Check the condenser fans and tighten their setscrews.
- Periodic removal of snow drifts will be required in northern climates.

Unit Storage

Location

The Rebel is an outdoor unit. However, the construction schedule may dictate storage either on the ground or in its final position at the site. If the unit is stored on the ground, additional precautions should be taken as follows:

- Make sure that the unit is well supported along the length of the base rail.
- Make sure that the unit is level (no twists or uneven ground surface).
- Provide proper drainage around the unit to prevent flooding of the equipment.
- Provide adequate protection from vandalism, mechanical contact, etc.
- Make sure all doors are securely closed and all latches closed.
- Units should be fitted with covers over the supply and return air openings.

Preparation for Storage

Supply Fans

1. Depending on local climate conditions, condensate may collect on components inside the units. To prevent surface rust and discoloration, spray all bare metal parts with a rust preventive compound.

Cabinet Sections

Once a month, open a door on each section and verify that no moisture or debris is accumulating in the unit.

Control Compartment

1. Daikin Applied recommends that the electronic control equipment in the unit be stored in a 5% to 95% RH (non-condensing) environment.
2. It may be necessary to put a heat source (light bulb) in the main control panel to prevent the accumulation of atmospheric condensate within the panel. The location and wattage of the heat source is dependent on local environmental conditions.
3. Check the control compartment every two weeks to confirm that the heat source is functional and is adequate for current conditions.

Filter Replacement

This unit is provided with filters are show in [Table 39](#). These filters are disposable and should be replaced periodically. Unit is equipped with a filter pull to assist in this process. See [Figure 151](#).

Table 39: Filter Sizes

Cabinet Size	Filter Size
03–06	4 – 16" × 16"
03–06 with ERW	6 – 16" × 16"
07–17	6 – 18" × 24"
07–17 with FPHX	10 – 18" × 24"
07–17 with ERW	6 – 18" × 20" 6 – 18" × 24"
16–31	9 – 18" × 24"
16–31 with FPHX	11 – 18" × 20" 6 – 24" × 24"
16–31 with ERW	13 – 18" × 24"

Restart

After extended storage, perform a complete start up. Inevitable accumulations of dirt, insect nests, etc. can contribute to problems if not cleaned out thoroughly prior to start up. In addition, thermal cycling tends to loosen mechanical and electrical connections. Following the startup procedure helps discover these and other issues that may have developed during the storage interval.

Figure 151: Rebel Filter Section



Fans

The supply, condenser and exhaust fan motors are permanently lubricated and require no periodic lubrication.

Vibration Levels

Each unit as shipped is trim balanced to operate smoothly. To provide satisfactory operation after shipping and installation, use accepted industry guidelines for field balancing fans.

NOTE: Excessive vibration from any cause contributes to premature fan and motor bearing failure. Monitor overall vibration levels every six months of operation. An increase in levels is an indication of potential trouble.

Vibration Causes

1. Wheel imbalance.
 - a. Dirt or debris on wheel blades.
 - b. Wheel distorted from overspeed.
2. Bent shaft.
3. Motor imbalance.
4. Fan section not supported evenly on foundation.

Periodic Service and Maintenance

Check all moving parts for wear every six months.

The Rebel exhaust fans are direct drive variable speed fan/motor combination, which do not have belts or pulleys to maintain. The bearings are permanently sealed and do not require periodic greasing. The Rebel 3-17 ton units have similar supply fans. The Rebel 16-31 tons supply fans have a direct drive motor. These larger motors are not permanently sealed and will require greasing every 9000 hours.

Rebel 7-15 ton units with axial (prop) exhaust fans and an Ebtron OA monitor may require removal of the exhaust fan VFD to service the OA monitor transceiver.

Refrigerant Charge

The Rebel unit has many configurable options that can affect the refrigerant charge. Actual unit charge is given on the unit's data plate found on the inside of the control panel. The Rebel unit uses electronic expansion valves that maintain peak efficiency. Liquid sub-cooling and suction super heat float and should not be used as an indication that charge needs to be added or removed from the system. If a leak is suspected, the full charge should be removed and weighed. Weight should be compared against the unit nameplate data. Unit should be re-charged with the amount given on the unit nameplate.

PVE oil is hygroscopic and does absorb moisture when exposed to atmosphere. Steps should be taken to minimize exposure time to atmosphere during any maintenance where the sealed system is to be opened.

NOTICE

Rebel units use DAPHNE FW68DE oil for all sizes and configurations.

Re-charging the Unit

The entire system must be evacuated using a suitable vacuum pump. The quality of vacuum is measured using a suitable micron gauge that has been calibrated. The vacuum level reading should be taken directly from the sealed system, not at the vacuum pump. The minimum vacuum level is 300 microns Hg. The vacuum pump should be isolated from the system and the observed. Decay should not be greater than 500 microns after 15 minutes.

The crankcase heaters should be on during the evacuation procedure. This will help boil any dissolved refrigerant in the oil.

When re-charging the unit there might be alarms in the MicroTech controller and the Building Automation System that need to be cleared.

See [page 154](#) for more information on evacuating charge.

Refrigerant Recovery

When servicing or decommissioning a unit, ensure that all of the refrigerant is safely removed from the system using the proper procedure.

- Ensure that the appropriate refrigerant recovery cylinders are used and that the correct number of cylinders are available.
- Recovered refrigerant should be put into dedicated cylinders that are labeled for that particular refrigerant.
- All recovery cylinders should have a pressure-relief valve and an associated shut-off valve in good working condition.
- Ensure that all recovery cylinders are evacuated and are cooled before conducting recovery operations.
- Prior to starting, confirm that all recovery equipment is in good working condition and that equipment instructions are available.
- Operational and calibrated weighing scales should be available.
- Ensure that all hoses used are free from any defects that could result in a leak. Each hose should be supplied with leak-free disconnect couplings.
- Prior to using a recovery machine, perform a safety check to ensure the unit is in proper working order, is up-to-date on routine maintenance, and that all electrical components are sealed to ensure there are no potential ignition sources.
- Return the recovered refrigerant to the supplier(s) in the correct recovery cylinder along with the proper waste transfer note.

NOTICE

Always consult with the manufacturer(s) if there is uncertainty about the performance capabilities of the refrigerant recovery components described in this section.

NOTICE

Special care must be taken to ensure that refrigerants are not mixed in both recovery system and especially in recovery cylinders.

Refrigerant Charging and/or Evacuation

When evacuating and charging refrigerant, ensure all necessary valves are open to prevent trapping refrigerant in the system. This can be done manually by navigating to **Main Menu\Cmp Circ Man Ctrl**. Some units are equipped with an **Evac/ChrgMode** menu selection, which will automatically set states for evacuation and/or charging.

Evac/ChrgMode

If the unit controller is equipped with **Evac/ChrgMode**, the unit must be in the OFF state to activate.

Initiating **Evac/ChrgMode** will set the unit to the following states:

- Compressors are locked out from operation.
- Unit controller commands the following components to the stated positions:

Component	Description	State
MHGRht Valve	Mod Hot-Gas Reheat, stepper motor	50% Open
EVI1Cap	Electronic expansion valves, stepper motor	100%
4WV	4-way valve	Off Leave in normal (cooling) state
CCH1, 2, 3	Variable compressor crank case heaters	On
RH Bleed Valve	-	Open

NOTE: The unit will only display the menu items it is configured for.

Leaving the unit in **Evac/ChrgMode** sets the unit to the following states:

- Valves and crank case heaters are returned to their normal states.
- There will be a delay before allowing compressors to be turned on. This allows valves to return to their normal state.

Evacuating Refrigerant Charge

1. Navigate to **Main Menu\Cmp Circ Man Ctrl** and place unit into **Evac/ChrgMode**.
2. Reclaim Refrigerant.

Charging the System with Refrigerant

1. Navigate to **Main Menu\Cmp Circ Man Ctrl** and place unit into **Evac/ChrgMode**.
2. Charge unit to value listed on the unit data plate.

WARNING

Never charge the unit with a refrigerant type other than what is listed on the data plate. Charging with an unauthorized refrigerant type could lead to property damage, serious personal injury, or death.

WARNING

Never perform maintenance to the refrigeration system unless refrigerant charge has been completely evacuated, as property damage, serious personal injury, or death may occur. Refer to the charging procedures described in "Refrigerant Charge" on page 153 or "R-32 Guidelines" on page 142 for guidance.

Refrigerant Sensors or Switches

CAUTION

Severe loss of charge may occur if the high refrigerant pressure switch is replaced before reclaiming the refrigerant. Replace pressure switch after reclaiming refrigerant.

Servicing Optional Electric Heater

DANGER

Hazardous voltage. May cause severe personal injury or death. Disconnect electric power before servicing equipment. More than one disconnect may be required to de-energize the unit.

If the electric heater is not operating properly, a qualified electrician should perform the following to check if the heater is damaged:

1. Measure continuity through all fuses.
2. Check that all electrical connections are tight. Look for signs of arcing.
3. Check the resistance to ground for each circuit. It should be infinite.
4. Check the resistance phase to phase for each circuit.
5. Check all contactors.

Phase Voltage Monitor (PVM)

The phase voltage monitor (Figure 152) is designed to protect three-phase loads from damaging power conditions. A microprocessor-based voltage and phase sensing circuit constantly monitors the three-phase voltages to detect harmful power line conditions. When a harmful condition is detected, its output relay is deactivated after a specified trip delay (Trip Delay). The output relay reactivates after power line conditions return to an acceptable level for a specified amount of time (Restart Delay). The trip and restart delays prevent nuisance tripping due to rapidly fluctuating power line conditions.

Factory defaults should be: Voltage (VAC) – Matching unit nameplate, Restart (sec) – 100, Unbalance trip (%) – 4%, Trip Delay (sec) – 5.

Figure 152: Phase Voltage Monitor

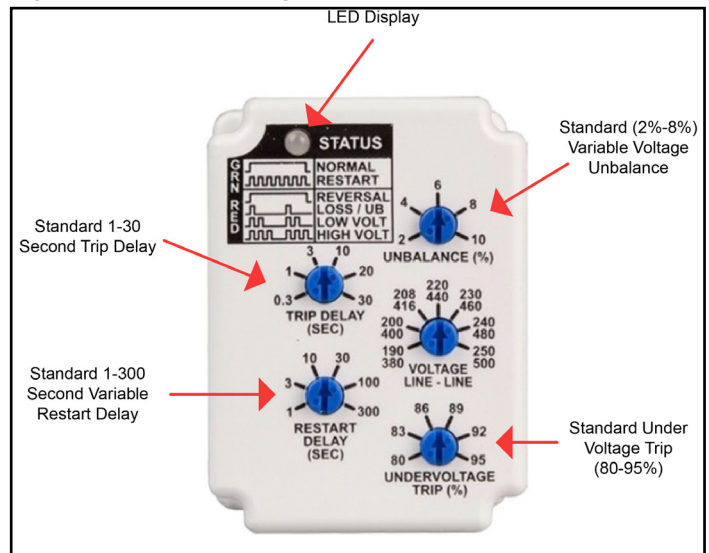

Figure 153: Phase Voltage Monitor Status Descriptions

LED STATUS		STATUS
GREEN		NORMAL (RELAY ON)
		RESTART (DELAY)
RED		REVERSAL
		LOSS/UB (UNBALANCE)
		LOW VOLT (UNDERVOLTAGE)
		HIGH VOLT (OVERVOLTAGE)

Cleaning Option E Coated Coils

⚠ WARNING

Prior to cleaning the unit, turn off and lock out the main power switch to the unit and open all access panels.

The following cleaning procedures are recommended as part of the routine maintenance activities for Option E Coated Coils. Documented routine cleaning of Option E Coated Coils is required to maintain warranty coverage.

Remove Surface Loaded Fibers

Surface loaded fibers or dirt should be removed prior to water rinse to prevent further restriction of airflow. If unable to back wash the side of the coil opposite that of the coils entering air side, then surface loaded fibers or dirt should be removed with a vacuum cleaner. If a vacuum cleaner is not available, a soft non-metallic bristle brush may be used. In either case, the tool should be applied in the direction of the fins. Coil surfaces can be easily damaged (fin edges bent over) if the tool is applied across the fins.

NOTE: Use of a water stream, such as a garden hose, against a surface loaded coil will drive the fibers and dirt into the coil. This will make cleaning efforts more difficult. Surface loaded fibers must be completely removed prior to using low velocity clean water rinse.

Periodic Clean Water Rinse

A monthly clean water rinse is recommended for coils that are applied in coastal or industrial environments to help to remove chlorides, dirt and debris. An elevated water temperature (not to exceed 130°F) will reduce surface tension, increasing the ability to remove chlorides and dirt. Pressure washer PSI must not exceed 900 psig and the nozzle should remain at least 1 foot from the coil to avoid damaging fin edges.

Routine Quarterly Cleaning of Option E Coated Coil Surfaces

Quarterly cleaning is essential to extend the life of an Option E Coated Coil and is required to maintain warranty coverage. Coil cleaning shall be part of the unit's regularly scheduled maintenance procedures. Failure to clean an Option E Coated Coil will void the warranty and may result in reduced efficiency and durability in the environment.

For routine quarterly cleaning, first clean the coil with the below approved coil cleaner (see approved products list under Recommended Coil Cleaners section, [Table 40](#)). After cleaning the coils with the approved cleaning agent, use the approved chloride remover (under the Recommended Chloride Remover section) to remove soluble salts and revitalize the unit.

Table 40: Option E Coated Coil Recommended Cleaning Agents

Cleaning Agent	Reseller	Part Number
Enviro-Coil Concentrate	Hydro-Balance Corp P.O. Box 730 Prosper, TX 75078 800-527-5166	H-EC01
Enviro-Coil Concentrate	Home Depot	H-EC01
Chloride Remover	Chlor*Rid Int'l, Inc. P.O. Box 908 Chandler AZ 85244 800-422-3217	Chlor*Rid DTS

Service and Warranty

Replacement Parts

MicroTech unit controllers are factory tested and documented prior to shipping. This is to assure the functionality of the controller and the unit and prevent dead on arrival controllers. Any miswiring of the MicroTech unit controller that damages it in any way, such as blown internal fuse, will not be covered under warranty.

When contacting Daikin Applied for service or replacement parts, provide the model number, serial number, and unit part number of the unit as stamped on the serial plate attached to the unit. For questions regarding wiring diagrams, provide the number on the specific diagram. If replacement parts are required, include the date of unit installation, the date of failure, an explanation of the malfunction, and a description of the replacement parts required.

NOTE: It is recommended to provide photos of the part to be replaced.

Scroll Compressor

All Daikin Applied Rooftop products include a first-year parts only warranty. The warranty period extends 12 months from startup or 18 months from date of shipment, whichever comes first. Labor to install these parts is not included with this warranty. Compressors are considered a part and are included in this standard warranty.

All Compressors

Replacement compressors for Daikin Applied Rooftop Units can be obtained from the Daikin Applied Service Parts department.

The decision to replace the failed portion of the compressor tandem, as opposed to replacing the entire tandem, must be decided based on the following.

1. **In warranty:** Warranty only covers replacement of the failed portion of the tandem.
2. **Out of warranty:** The customer decides whether to replace the entire tandem or just a portion.
3. Some equipment may include the extended 2nd - 5th year compressor warranty option.

Order the replacement compressor through the Daikin Applied Parts Department (Minneapolis).

1. Contact the Daikin Applied Parts Department for compressor availability.
2. Send a completed parts order form to the Daikin Applied Parts Department.
3. The Parts Department processes the order and the compressors are shipped from our Dayton, OH warehouse via ground transportation. If next-day air is required, indicate this on the parts order form and a freight charge will be billed to your account. Air freight costs are not covered under the Daikin Applied warranty.
4. After the failed compressor is replaced, return it to Daikin Applied Parts Department with a Return Goods Tag attached, which you will receive in the mail. It must be attached to the compressor. The Return Goods Tag has instructions on where to send the compressor. If the compressor is not returned, you will be billed for the replacement compressor.
5. Consideration may be given at this time to a compressor teardown analysis, depending on the history of failures.

Limited Warranty



**DAIKIN APPLIED AMERICAS INC.
LIMITED PRODUCT WARRANTY
(United States and Canada)**

WARRANTY

Daikin Applied Americas Inc. dba Daikin Applied ("Company") warrants to contractor, purchaser and any owner of the product (collectively "Owner") that, subject to the exclusions set forth below Company, at its option, will repair or replace defective parts in the event any product manufactured by Company, including products sold under the brand name Daikin and used in the United States or Canada, proves defective in material or workmanship within twelve (12) months from initial startup or eighteen (18) months from the date shipped by Company, whichever occurs first. Authorized replacement parts are warranted for the remainder of the original warranty. All shipments of such parts will be made FOB factory, freight prepaid and allowed. Company reserves the right to select carrier and method of shipment. In addition, Company provides labor to repair or replace warranty parts during Company normal working hours on products with rotary screw compressors or centrifugal compressors. Warranty labor is not provided for any other products.

Company must receive the Registration and Startup Forms for products containing motor compressors and/or furnaces within ten (10) days of original product startup, or the ship date and the startup date will be deemed the same for determining the commencement of the warranty period and this warranty shall expire twelve (12) months from that date. For additional consideration, Company will provide an extended warranty(ies) on certain products or components thereof. The terms of the extended warranty(ies) are shown on a separate extended warranty statement.

No person (including any agent, sales representative, dealer or distributor) has the authority to expand the Company's obligation beyond the terms of this express warranty or to state that the performance of the product is other than that published by Company.

EXCLUSIONS

1. If free warranty labor is available as set forth above, such free labor does not include diagnostic visits, inspections, travel time and related expenses, or unusual access time or costs required by product location.
2. Refrigerants, fluids, oils and expendable items such as filters are not covered by this warranty.
3. This warranty shall not apply to products or parts : (a) that have been opened, disassembled, repaired, or altered, in each case by anyone other than Company or its authorized service representative; (b) that have been subjected to misuse, abuse, negligence, accidents, damage, or abnormal use or service; (c) that have not been properly maintained; (d) that have been operated or installed, or have had startup performed, in each case in a manner contrary to Company's printed instructions; (e) that have been exposed, directly or indirectly, to a corrosive atmosphere or material such as, but not limited to, chlorine, fluorine, fertilizers, waste water, urine, rust, salt, sulfur, ozone, or other chemicals, contaminants, minerals, or corrosive agents; (f) that were manufactured or furnished by others and/or are not an integral part of a product manufactured by Company; or (g) for which Company has not been paid in full.
4. This warranty shall not apply to products with rotary screw compressors or centrifugal compressors if such products have not been started, or if such startup has not been performed, by a Daikin Applied or Company authorized service representative.

SOLE REMEDY AND LIMITATION OF LIABILITY

THIS WARRANTY CONSTITUTES THE SOLE WARRANTY MADE BY COMPANY. COMPANY'S LIABILITY TO OWNER AND OWNER'S SOLE REMEDY UNDER THIS WARRANTY SHALL NOT EXCEED THE LESSER OF: (i) THE COST OF REPAIRING OR REPLACING DEFECTIVE PRODUCTS; AND (ii) THE ORIGINAL PURCHASE PRICE ACTUALLY PAID FOR THE PRODUCTS. COMPANY MAKES NO REPRESENTATION OR WARRANTY, EXPRESS OR IMPLIED, REGARDING PREVENTION OF MOLD/MOULD, FUNGUS, BACTERIA, MICROBIAL GROWTH, OR ANY OTHER CONTAMINATES. THIS WARRANTY IS GIVEN IN LIEU OF ALL OTHER WARRANTIES, INCLUDING, WITHOUT LIMITATION, THE IMPLIED WARRANTIES OF MERCHANTABILITY, FITNESS FOR A PARTICULAR PURPOSE, AND NON-INFRINGEMENT, WHICH ARE HEREBY DISCLAIMED. IN NO EVENT AND UNDER NO CIRCUMSTANCE SHALL COMPANY BE LIABLE TO OWNER OR ANY THIRD PARTY FOR INCIDENTAL, INDIRECT, SPECIAL, CONTINGENT, CONSEQUENTIAL, DELAY OR LIQUIDATED DAMAGES FOR ANY REASON, ARISING FROM ANY CAUSE WHATSOEVER, WHETHER THE THEORY FOR RECOVERY IS BASED IN LAW OR IN EQUITY, OR IS UNDER A THEORY OF BREACH CONTRACT OR WARRANTY, NEGLIGENCE, STRICT LIABILITY, OR OTHERWISE. THE TERM "CONSEQUENTIAL DAMAGE" INCLUDES, WITHOUT LIMITATION, THOSE DAMAGES ARISING FROM BUSINESS INTERRUPTION OR ECONOMIC LOSS, SUCH AS LOSS OF ANTICIPATED PROFITS, REVENUE, PRODUCTION, USE, REPUTATION, DATA OR CROPS.

ASSISTANCE

To obtain assistance or information regarding this warranty, please contact your local sales representative or a Daikin Applied office.

Form No. 933-430285Y-01-A (11/2023)
Part No. 043028500 Rev.0F

Rooftop Equipment Warranty Registration Form

Warranty Exclusion

See Warranty Registration Form 13F-4157, Part 8 – Furnace Check, Test, and Start.

Manifold Pressures

Record Pressures as Applicable. Reference "[Gas Heating Capacity Data](#)" on page 53.

P1: _____ inches WC or _____ kPa

P2: _____ inches WC or _____ kPa

P3: _____ inches WC or _____ kPa

P4: _____ inches WC or _____ kPa

P5: _____ inches WC or _____ kPa

High Fire (100% Rate) Combustions

Single Flue Furnace

CO₂: _____ ppm

CO: _____ ppm

Double Flue Furnace

Outer Flue CO₂: _____ ppm Inner Flue CO₂: _____ ppm

Outer Flue CO: _____ ppm Inner Flue CO: _____ ppm

In-Warranty Return Material Procedure

Material other than compressors may not be returned except by permission of authorized factory service personnel of Daikin Applied at Minneapolis, Minnesota.

A "return goods" tag will be sent to be included with the returned material. Enter the information as called for on the tag in order to expedite handling at our factories and issuance of credits. All parts shall be returned to the factory designated on the return goods tag, transportation charges prepaid.

The return of the part does not constitute an order for replacement. A purchase order for the replacement part must be entered through your nearest Daikin Applied representative. The order should include the component's part number and description and the model and serial numbers of the unit involved.

If it is determined that the failure of the returned part is due to faulty material or workmanship within the standard warranty period, credit will be issued on the customer's purchase order.

Warranty Registration Form



Rebel Equipment Warranty Registration Form

To comply with the terms of Daikin Applied Warranty, register start date and upload this form within 10 days to the Warranty Department of Daikin Applied.

Check, test, and start procedure for Rebel rooftop roof mounted air conditioners with or without heat recovery and roof mounted air handlers.

GENERAL INFORMATION

Job Name: _____ Unit No.: _____

SOI No.: _____

Installation address: _____

City: _____ State: _____

Purchasing contractor: _____

City: _____ State: _____

Name of person doing start-up: _____

Company name: _____

Address: _____

City/State/Zip: _____

UNIT INFORMATION

Unit model number: _____

Unit serial number: _____

Compressor 1 model number: _____ Serial number: _____

Compressor 3 model number: _____ Serial number: _____

- NOTE:**
1. Unit does not require high pressure switch testing
 2. Refrigerant pressures can be checked from the MT III controller. Refrigerant gages are not needed.
 3. Ensure proper unit phasing.
 4. Compressor 3 might not operate during startup due to ambient conditions and compressor operating envelope.

13F-4157 (07/2025)

©2025 Daikin Applied • (800) 432-1342 • www.DaikinApplied.com



Rebel Equipment Warranty Registration Form (continued)

Select Yes or No. If not applicable to the type of unit, select N/A.

I. INITIAL CHECK

- A. Is any shipping damage visible?
B. Has the discharge static pressure reference been properly located in the building?
C. Do fans turn freely?
D. Electrical service corresponds to unit nameplate?

D1. Voltage at Terminal Block | Disconnect 1-2 _____ V 2-3 _____ V 1-3 _____ V

- E. Unit phased correctly?
F. Is the main disconnect adequately fused and are fuses installed?
G. Are crankcase heaters operating, and have they been operating 24 hours prior to start-up?
H. Are all electrical power connections tight?
I. Is the condensate drain trapped?

II. FAN DATA

- A. Check rotation of supply fan?
B. Voltage at supply fan motor: 1-2 _____ V 2-3 _____ V 1-3 _____ V
C. Supply fan motor amp draw per phase: 1-2 _____ A 2-3 _____ A 1-3 _____ A
D. What is the supply fan rpm?
E. Record supply static pressure at unit in inches of H2O:
F. Record return static pressure at unit (with outside air dampers closed) in inches of H2O:

III. START-UP COMPRESSOR OPERATION

- A. Do compressors have holding charge?
B. Are compressor shipping brackets removed?
C. Are compressors rotating in the right direction?
D. Do condenser fans rotate in the right direction?
E. Ambient temperature (°F):
F. Compressor amperage:
Compressor #1: Phase 1 _____ Phase 2 _____ Phase 3 _____
Compressor #3: Phase 1 _____ Phase 2 _____ Phase 3 _____



Rebel Equipment Warranty Registration Form (continued)

Select Yes or No. If not applicable to the type of unit, select N/A.

IV. PERFORMANCE DATA (Unit to run at steady state for 15 minutes)

- A. Discharge pressure, one compressor: Circuit #1 _____ psig
- B. Suction pressure, one compressor: Circuit #1 _____ psig
- C. Liquid temperature (°F): _____
- D. Suction line temperature °F from unit controller: _____
- E. Discharge line temperature °F from unit controller: _____
- F. Superheat temperature °F from unit controller: _____
- G. Sub-cooling line temperature °F from unit controller: _____
- H. Record discharge air temperature at discharge of unit (°F): _____
- I. Are all control refrigerant lines secure to prevent excessive vibration and wear? Yes No N/A
- J. Are all valve caps and packing tight after start-up? Yes No N/A
- K. Did unit control DAT to DAT setpoint? Yes No N/A

V. Hot Water Coil

- A. Pressure test OK? Yes No N/A

VI. Heat Recovery

- A. Heat wheel rotates freely? Yes No N/A
- B. Heat wheel VFD operates properly? Yes No N/A
- C. Heat wheel VFD Model No. _____ Serial No. _____
- D. Check for air bypass around heat wheel. Yes No N/A

VII. ELECTRIC HEAT

- A. Electrical heat service corresponds to unit nameplate? Yes No N/A
Volts _____ Hertz _____ Phase _____
- B. Are there any signs of physical damage to the electric heat coils? Yes No N/A
- C. Have all electrical terminals been tightened? Yes No N/A
- D. Does sequence controller stage contactors properly? Yes No N/A
- E. Electric heater voltage across each phase: _____ L1 _____ L2 _____ L3
- F. Amp draw across each phase at each heating stage:

	Stage 1	Stage 2	Stage 3	Stage 4	Stage 5	Stage 6
Phase L1:	_____	_____	_____	_____	_____	_____
Phase L2:	_____	_____	_____	_____	_____	_____
Phase L3:	_____	_____	_____	_____	_____	_____
- G. FLA: L1 _____ L2 _____ L3 _____
- H. Operate electric heat with fans off. Electric heat must cycle on high limit control Yes No N/A



Rebel Equipment Warranty Registration Form (continued)

Select Yes or No. If not applicable to the type of unit, select N/A.

VIII. FURNACE CHECK, TEST, & START

- A. Gas pressure at main (inches w.c.): _____
- B. Gas pressure at manifold (inches w.c.): _____
- C. High limit control OK? Yes No N/A
- D. Flame failure shutoff (seconds): _____
- E. Airswitch OK? Yes No N/A
- F. Main Gas Valve Close-Off OK? Yes No N/A
- G. Modulation Gas Heat Performance

Gas Pressure	
Mod. Valve	Reg. Valve
25% _____ in Wc.	25% _____ in Wc.
50% _____ in Wc.	50% _____ in Wc.
75% _____ in Wc.	75% _____ in Wc.
100% _____ in Wc.	100% _____ in Wc.

IX. MAINTAINING MICROTECH CONTROL PARAMETER RECORDS

After the unit is checked, tested, and started and the final control parameters are set, record the final settings. Keep these records on file and update whenever changes to the control parameters are made. Keeping a record facilitates any required analysis and troubleshooting of the system operation and facilitates restoration after a controller replacement.

Thank you for completing this form. Please sign and date below.

Signature _____ Startup date: _____

Register equipment start date and upload form on the Daikin Applied FieldCare Portal at <https://fieldcare.daikinapplied.com>

Please fill out the Daikin Applied "Quality Assurance Survey Report" and list any additional comments that could affect the operation of this unit; e.g., shipping damage, failed components, adverse installation applications, etc. If additional comment space is needed, write the comment(s) on a separate sheet, attach it to the Survey Report and return it to the Warranty Department of Daikin Applied with the completed Equipment Warranty Registration form.

Clear Form



Quality Assurance Survey Report

To whom it may concern:
Please review the items below upon receiving and installing our product. Select N/A on any item that does not apply to the product.

Job Name: _____ Daikin Applied S.O. No. _____

Installation address: _____

City: _____ State: _____

Purchasing contractor: _____

City: _____ State: _____

Name of person doing start-up (print): _____

Company name: _____

Address: _____

City/State/Zip: _____

Unit model number: _____ Unit serial number: _____

1. Is there any shipping damage visible? Yes [] No [] N/A []

Location on unit _____

2. How would you rate the overall appearance of the product; i.e., paint, fin damage, etc.?
Excellent [] Good [] Fair [] Poor []

3. Did all sections of the unit fit together properly? Yes [] No [] N/A []

4. Did the cabinet have any air leakage? Yes [] No [] N/A []

Location on unit _____

5. Were there any refrigerant leaks? Yes [] No [] N/A []

From where did it occur? Shipping [] Workmanship [] Design []

6. Does the refrigerant piping have excessive vibration? Yes [] No [] N/A []

Location on unit _____

7. Did all of the electrical controls function at start-up? Yes [] No [] N/A []

Comments _____

8. Did the labeling and schematics provide adequate information? Yes [] No [] N/A []

9. How would you rate the serviceability of the product?
Excellent [] Good [] Fair [] Poor []

10. How would you rate the overall quality of the product?
Excellent [] Good [] Fair [] Poor []

11. How does the quality of Daikin Applied products rank in relation to competitive products?
Excellent [] Good [] Fair [] Poor []

Comments _____

Please list any additional comments which could affect the operation of this unit; i.e., shipping damage, failed components, adverse installation applications, etc. If additional comment space is needed, write the comment(s) on a separate sheet, attach the sheet to this completed Quality Assurance Survey Report, and return it to the Warranty Department with the completed preceding "Equipment Warranty Registration Form".

COMPLETE HVAC SYSTEM SOLUTIONS

SELF-CONTAINED | ROOFTOPS | COILS | CONDENSING UNITS
AIR HANDLERS | WATER-COOLED CHILLERS | AIR-COOLED CHILLERS
MODULAR CENTRAL PLANTS | CONNECTED BUILDING CONTROLS
UNIT HEATERS | FAN COILS | AIR PURIFIERS | WATER SOURCE HEAT PUMPS
VARIABLE AIR VOLUME UNITS | UNIT VENTILATORS



13600 INDUSTRIAL PARK BLVD. | MINNEAPOLIS, MN 55441
1-800-432-1342 | 763-553-5330

LEARN MORE AT
DAIKINAPPLIED.COM

PART NUMBER: IM1370

© 2026 DAIKIN APPLIED | (800) 432.1342 | WWW.DAIKINAPPLIED.COM